

CERTIFICATE / DIPLOMA IN FASHION DESIGNING



BASIC SEWING TECHNIQUE
CFD/DFD-01

Block-1

Message for the Students

Dr. Babasaheb Ambedkar Open (University is the only state Open University, established by the Government of Gujarat by the Act No. 14 of 1994 passed by the Gujarat State Legislature; in the memory of the creator of Indian Constitution and Bharat Ratna Dr. Babasaheb Ambedkar. We Stand at the seventh position in terms of establishment of the Open Universities in the country. The University provides as many as 54 courses including various Certificate, Diploma, UG, PG as well as Doctoral to strengthen Higher Education across the state.



On the occasion of the birth anniversary of Babasaheb Ambedkar, the Gujarat government secured a quiet place with the latest convenience for University, and created a building with all the modern amenities named 'Jyotirmay' Parisar. The Board of Management of the University has greatly contributed to the making of the University and will continue to this by all the means.

Education is the perceived capital investment. Education can contribute more to improving the quality of the people. Here I remember the educational philosophy laid down by Shri Swami Vivekananda:

“We want the education by which the character is formed, strength of mind is increased, the intellect is expand and by which one can stand on one’s own feet”.

In order to provide students with qualitative, skill and life oriented education at their threshold. Dr. Babaasaheb Ambedkar Open University is dedicated to this very manifestation of education. The university is incessantly working to provide higher education to the wider mass across the state of Gujarat and prepare them to face day to day challenges and lead their lives with all the capacity for the upliftment of the society in general and the nation in particular.

The university following the core motto ‘स्वाध्यायः परमम् तपः’ does believe in offering enriched curriculum to the student. The university has come up with lucid material for the better understanding of the students in their concerned subject. With this, the university has widened scope for those students who are not able to continue with their education in regular/conventional mode. In every subject a dedicated term for Self Learning Material comprising of Programme advisory committee members, content writers and content and language reviewers has been formed to cater the needs of the students.

Matching with the pace of the digital world, the university has its own digital platform Omkar-e to provide education through ICT. Very soon, the University going to offer new online Certificate and Diploma programme on various subjects like Yoga, Naturopathy, and Indian Classical Dance etc. would be available as elective also.

With all these efforts, Dr. Babasaheb Ambedkar Open University is in the process of being core centre of Knowledge and Education and we invite you to join hands to this pious *Yajna* and bring the dreams of Dr. Babasaheb Ambedkar of Harmonious Society come true.



Prof. Ami Upadhyay
Vice Chancellor,
Dr. Babasaheb Ambedkar Open University,
Ahmedabad.

Editor

Prof. (Dr.) Ami Upadhyay
Vice Chancellor
Dr.Babasaheb Ambedkar Open University, Ahmedabad

Dr.Awa Shukla
Assistant Professor (Subject Head)/ Director (I/c) Student Services
Dr.Babasaheb Ambedkar Open University, Ahmedabad

Programme Advisory Committee

Prof. (Dr.) Ami Upadhyay
Vice Chancellor
Dr.Babasaheb Ambedkar Open University, Ahmedabad

Dr.Awa Shukla
Assistant Professor (Subject Head)/ Director (I/c) Student Services
Dr.Babasaheb Ambedkar Open University, Ahmedabad

Dr. Rajshree Yadav
Prof. (CACDDM)
Government Girls College,Ahmedabad

Dr. Hemalata Patel
Prof. (Home-Science)
Mahila Home-Science College, Mahesana

Ms. Devyani Dhandhukiya
Fashion Designer & Freelancer, Ahmedabad

Reviewers

Dr. Rajshree Yadav
Prof. (CACDDM)
Government Girls College,Ahmedabad

Dr. Hemalata Patel
Prof. (Home-Science)
Mahila Home-Science College, Mahesana

Content Writers

Ms. Donika P. Patel

Programme Coordinator

Dr.Awa Shukla
Director (I/c) Student Services
Dr.Babasaheb Ambedkar Open University, Ahmedabad

Publisher

Dr.Bhavin Trivedi
Registrar (I/c), Dr.Babasaheb Ambedkar Open University, Ahmedabad

ISBN-978-93-89456-69-1

All rights reserved. No part of this work may be reproduced in any form, by mimeograph or any other means without permission in writing from Dr. Babasaheb Ambedkar Open University, Ahmedabad.



Dr. Babsaheb Ambedkar Open University

(Established by Government of Gujarat)

**CERTIFICATE/DIPLOMA IN FASHION DESIGNING
DESIGNING BASIC SEWING TECHNIQUE**

CFD-01 /DFD-01

Block

1

Unit 1

Sewing Machines

Unit 2

Commercial Machines for Sewing, Cutting & Finishing

Unit 3

Sewing Tools and Equipments

Unit 4

Permanent and Temporary Hand Stitches

Unit 5

Preparing Fabric before Sewing

Unit 6

Basic Seams

Unit 7

Seam Finishes

Unit 1: Sewing Machines

1.0 Objectives

1.1 Introduction

1.2 History of Sewing Machine

1.3 types of Sewing Machine

1.3.1 Hand Operated Sewing Machine

1.3.2 Treadle Sewing Machine

1.3.3 Electric Sewing Machine

1.4 Parts and Functions of Sewing Machine

Check Your Progress I

1.5 Preparation before Sewing

1.6 Common Machine Troubles

1.7 Machine Fault and How to Correct Them

1.8 Care & Maintenance of Sewing Machine

Check Your Progress II

Multiple Choice Questions

1.9 Let Us Sum Up

1.10 Key Words

1.11 Some Useful Books

Answers

1.0 Objectives

- In this Unit, You will able to understand history regarding sewing machine
- To Gain knowledge regarding operation of sewing machine
- To know about general care maintains and solution regarding faults during sewing
- To understand different part of sewing machines.

1.1 Introduction

Sewing machine is a useful device when taken proper care it can be used for many years. Apparel making is one of the important elements of the fashion designing. Skill of making garment can be full filled by this important technical machine. The rate of production making garment is perfume efficiently by this technical machine so it is an important machine for fashion designer, skill labor and those who are interested to do work with the fashion designer. A decent sewing machine is required to acquire quality items. Sewing machines are

available commercially in different models, such as domestic model, tailor model, industrial model, portable and electronic model.

1.2 History of Sewing Machine

A sewing machine is utilized to line texture together with string. Sewing machines were a development of the modern insurgency that made it conceivable to sew quicker than individuals could sew by hand. Some sewing machines are likewise utilized for weaving. Since the innovation of the principal working sewing machine, for the most part considered to have been crafted by Englishman Thomas Saint in 1790, the sewing machine has significantly improved the effectiveness and profitability of the garments business. Sewing is an innovative and intriguing aptitude. The information of sewing gives a certain inclination when it is connected to the development of pieces of clothing. The prior technique for sewing by hand isn't appropriate for all phases of article of clothing making. In this manner, significant accentuation is given to machine sewing. There are a few machines in the market today, each with its very own alluring highlights and focal points. Sewing machines run from most fundamental having just straightforward lock line to the electronic machines that utilization propelled PC innovation having different capacities for instance channeling, authoritative, unsettling, creasing, darning, sewing and notwithstanding making buttonholes and connecting latches. A decent sewing machine is required to acquire quality items. One must be comfortable with the attributes of various sorts of machines for choosing fitting machine, contingent on the capacity and necessities of the individual.

1.3 Types of Sewing Machine

Sewing machines are presently accessible in different models, for Ex, Hand-operated sewing machine, Treadle sewing machine, Electric sewing machine, convenient and cabinet models. They might be worked by hand, treadle or electric motor.

1.3.1 Hand-operated Sewing Machine



Figure-1 (<https://www.contrado.co.uk/blog/history-of-the-sewing-machine/>)

This is the straightforward form of sewing machine which is worked by hand. A separable handle given to the flywheel is utilized to work the machine. This machine is commonly appropriate for local reason since it doesn't help in accelerating the work.

1.3.2 Treadle Sewing Machine



Figure 2 (<https://www.kcpappu.in/singer-sewing-machine.html>)

Treadle sewing machine is exactly like the hand sewing machine, but it is operated by paddle or foot, using an additional stand. In this machine balance wheel is operated wheel is worked by a belt with the assistance of lower stand, which is driven by feet. This machine is affordable where there is no power supply.

Electric Sewing Machine



Figure-3

[\(http://www.imasewingsolutions.in/product/model-ddl-8100e-1-needle-lock-stitch-sewing-machine-complete-set/\)](http://www.imasewingsolutions.in/product/model-ddl-8100e-1-needle-lock-stitch-sewing-machine-complete-set/)

This is the fastest sewing machine. One needs practice to deal with it. In an electric machine the equalization wheel comes to movement by a belt, which is connected to an electric engine.

1.4 Parts and Functions of Sewing Machine

The basic structure of sewing machine is a comparative whether it is hand-worked sewing, treadle sewing machine or electric sewing machine. The principal bits of a sewing are recorded underneath and found in fig.

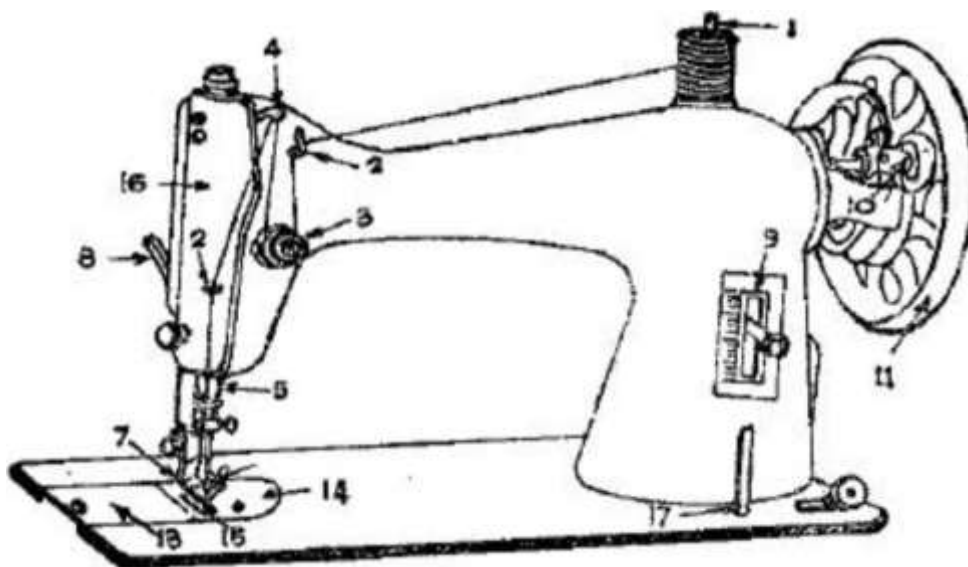

Figure-4

The fundamental structure of sewing machine is a similar whether it is handoperated sewing, treadle sewing machine or electric sewing machine. The fundamental pieces of a sewing are recorded underneath and found in fig.

- 1 **Spool pin:** It is fitted on the highest point of the arm to hold the reel.
- 2 **Thread guide:** It is a little gap made of spring wire through which string runs straightforwardly to needle.
- 3 **Tension disc:** The two ward plates set up together with the raised sides confronting one another, form the pressure circle. The string goes between the two. The strain of the string is balanced by a spring and nut which increments or diminishes pressure
- 4 **Take up lever:** It is lever fitted to the body of the arm with a small hole through which the thread passes. Its up and down motion feeds the thread to the needle and tightens the loop formed by the shuttle and loosening the top thread to complete the stitch.
- 5 **Needle bar:** This is a steel bar to hold the needle toward one side with the assistance of a clamp. Its main function is to offer movement to the needle.
- 6 **Bobbin case:** This moves into position to get the top string and form the stitch, as the needle is lowered in to the bobbin chamber.
- 7 **Presser foot:** It is fixed to the presser bar to hold the material solidly in position when brought down.
- 8 **Presser foot lifter:** A switch connected to the presser bar for raising and bringing down the presser foot.
- 9 **Stitch regulator:** this controls the length of the stitch. 2.5 to 3 for regular stitch length stitch regular kept on 2.5 to 3 and for big stitch regulator kept on 5
As well as for small stitch regulator kept in 0 to 2 and maintains the stitch length. This controls the length of fasten. A few controllers can join backward.
- 10 **Bobbin winder:** A straightforward instrument utilized for winding thread on the bobbin.

- 11 Fly wheel:** when this is made to rotate, it works the system of the movement.
- 12 Clutch or thumb screw:** This is in the center point of the fly wheel draws in and withdraws the sewing system.
- 13 Slide plate:** A rectangular plate, which encourages the expulsion of the bobbin case without lifting the machine.
- 14 Needle plate or throat plate:** A semi-round about circle with an opening to enable the needle to go through it.
- 15 Feed dog:** This comprises of a lot of teeth fitted beneath the needle plate. It pushes the fabric ahead while sewing.
- 16 Face plate:** this is a cover which when removed gives access to the oiling points on needle bar, presser bar and thread take-up lever.
- 17 Spool pin for bobbin winding:** spool of string is put on this at the season of bobbin winding.
- 18 Pedal:** it is made out of iron. When pressing this with foot, the machine works.

Check Your Progress I

Q-1 Give difference between hands operated and treadle sewing machine.

Q-2 Write functions of pressure foot.

Q-3 Write functions of stitch regulator.

Q-4 Write functions of thread take-up lever and needle bar.

Q-5 Write about history of sewing machine in brief.

1.5 Preparation before sewing

Before beginning real machining, it should be watched that the needle of the machine is of right size, is sharp and accurately set. The bobbin should be equally set. Quickly, the different strides of pre-arrangement are:

- Winding the bobbin
- Upper threading
- Drawing the bobbin thread
- Tension adjustments
- Pressure and feed adjustments
- Selection of thread and needle

Winding the bobbin

Bobbins wind differently on various machines, yet for the most part the string is first set on a spool pin situated underneath the flywheel and afterward drawn through the string aide close to the spool pin. Now with your hand wind the finish of the string on the bobbin in clockwise direction and place it on the winder. Turn the bobbin on the winder until the stick like projection on the winder fits into the space on the bobbin, hence holding bobbin set up. At that point press the winder switch down until the elastic ring contacts the center point of the fly wheel held there. Relax the thumb screw and run the machine, holding the thread end freely. Ensure that the string twists on the bobbin evenly and that you don't fill the bobbin excessively full.

Upper threading

Raise the take up switch to its most noteworthy point by turning the equalization wheel towards you for upper thread. Spot the spool of the thread on spool pin. Lead the string into string guide, at that point go through strain plates and into little wire spring lastly through the opening of the needle from left to right. Draw around 2 inches of string through the needle. For the lower string hold the bobbin among thumb and fore finger of the left hand with the string driving on top, into the slot or shuttle race.

Drawing the bobbin thread

Raise the take up switch to its most elevated point. Holding the finish of the top thread with your left hand, gradually turn the fly wheel around once so the needle goes down and afterward comes up to its most elevated position. Force the finish of the needle thread. At that point a bobbin thread will show up through the needle gap. Dismantle the circle to bring the finish of the bobbin thread out.

Tension adjustments

When pressure is correct in both thread, the tension is balanced, the threads interlock in the middle of the material to make a perfect or balanced stitch. The seam is flat and elastic without being loose and there is no seam grin when the seam is stressed. If there is too much pressure on the tension discs, not enough thread is fed into the stitching and the tension is tight. The material puckers, the seam is strained and the stitches break. If there is too little pressure, too much thread is fed, the tension is too loosed and the seam is loose and weak. The link position is a good indicator of which thread tension is incorrect. When the tension on the top or needle, thread is too tight or the tension on the bottom or bobbin thread is too loose, the top thread lies along the surface of the material and the thread forms loops on the top. When the tension of the top or needle, thread is too loose or the bottom or bobbin thread is too tight, the bottom thread lies along the underside of the material and the top thread forms loops on the underside.

To adjust the top thread tension, regulator situated on the front of the machine adjusts the tension discs. To decrease tension, turn dial to lower number if present. To increase tension, turn dial to high number. The bobbin thread tension is controlled by a screw on the bobbin. Clockwise turning increases the tension whereas anti-clockwise turning decreases tension.

Pressure and feed adjustments

Weight implies the descending power applied on the texture by the presser foot, to hold the layers with the goal that they move together equally during sewing. The feed applies upward power that moves the texture to the back of the machine. The two powers weight and feed cooperate to create appropriately sewed crease. Weight has a few capacities. It holds the texture layers so that they move uniformly with each other. It holds the material tight and it guarantees that the join is appropriately set in the material and that an even fasten pressure, and line length are kept up. Weight likewise keeps the texture from being maneuvered down into the bobbin region and can cause skipped join.

The essential capacity of feed is to move the texture into position for each fasten. Feed additionally helps in holding the texture layers tight during stitch formation. Feed is constrained by the join length controller. The littler the line length setting, the shorter the separation the feed moves the texture for each progressive fasten.

The measure of weight required relies upon the weight and thickness of the material. Lighter and slenderer the texture weight, the lighter the weight required and the other way around.

Choice of thread and needle

Fabric	Fabric	Thread	Needle	Stitch length
<ul style="list-style-type: none"> Fine woven fabrics: lawn, voile, organdie, silk chiffon, organza, crepe de chine, georgette, fine lace 	Synthetics, cotton & blends	Synthetic 60 Mercerized 50	9-11	10-15
	Synthetics, cotton & blends	Synthetic 60 Mercerized 50	11-14	12-15
<ul style="list-style-type: none"> Light weight woven fabrics: poplin, 	Synthetics, cotton &	50 Mercerized	11-14	12-15

gingham, silk, crepe cotton, corduroy, and velveteen	blends	Synthetic 60 Mercerized 50		
<ul style="list-style-type: none"> • Medium weight woven fabrics: Silk, brocade, taffeta, linens, some denims, tweed, gabardine, waterproof fabrics 	Synthetics, cotton & blends	Mercerized 50	16-18 14	10-12
<ul style="list-style-type: none"> • Heavy weight woven fabrics: suiting, thick corduroy, denim, canvas, double faced wool, heavy furnishing fabric 		Synthetic 60 Mercerized 50 Mercerized 50		

Types of threads

The regular fiber strings accessible in the market are cotton and silk. Cotton string comes in two assortments mercerized and un-mercerized. Mercerized cotton is more grounded and has brilliance. Silk string is a generally useful string and consolidates quality with versatility however isn't effectively accessible in India in little spools.

The manufactured strings are typically produced using polyester and terylene. Cottons or materials ought not to be sewed with engineered string, as the string won't probably withstand the warmth while being pressed. Cotton sewing string arrives in an incredible scope of sizes, from number 8 (exceptionally overwhelming for work on canvas, and so forth.) to number

100 (extremely fine). Wool and silk ought to ideally be sewed either with mercerized cotton or silk strings as it were. Mixed textures might be sewed with engineered string appropriate to the predominant fiber in its substance. Strings whether natural or synthetic are produced in different thickness: higher the number, better is the string and smaller the number, coarser is the string. Remember that a similar string ought to be utilized for the bobbin and top spool.

The string utilized for sewing an article of clothing must obviously mix in with the texture and be unnoticeable. In the event that the string is only a shade darker than the texture, it will mix in well; a great test is to lay a solitary strand of the string over the texture. If fabric is plain or printed, the colour of the thread should match the strong colour of the plain or print.

Selection of Needles

Machine needles are chosen by the weight and different qualities of the texture, just as the string type being utilized for development. For the most part, a needle ought to be fine enough to infiltrate the texture without harming it but then have an eye, which is huge enough so the string does not shred or break. Needles come in different sizes, from fine (size 9) for light weight fabric to thick (size 18) for exceptionally overwhelming weight and thick fabrics.

Needles likewise come in three distinct tips or focuses:

- Regular sharp needle - perfect for almost all woven fabrics.
- Ball point needle - the marginally adjusted tip is prescribed for all elastic fabrics and knit fabrics. Accessible in sizes 9-16
- Wedge point needle – this needle has been extraordinarily intended for leather and vinyl. Available in sizes 11-18.

1.6 Common machine troubles

The sewing like any other machine, gives troubles of stitching like thread breaking, uneven stitching, puckering, bending and breaking of needle, looping of threads, skipping of stitches, etc. little problems with the sewing machine can be very irritating and time consuming. They can happen to even the most experienced seamstress. A person operating the machine should be able to rectify these and solve the problems. Some of the common machine problems are listed below:

- 1 Breaking needles

- 2 Looping of stitches
- 3 Skipping stitches
- 4 Variation in stitch length
- 5 Puckered seams
- 6 Upper thread breaking
- 7 Lower thread breaking
- 8 Machine not feeding properly
- 9 Machine working heavily
- 10 Layers feed unevenly
- 11 Fabric does not feed in straight line
- 12 Causes damage to fabric
- 13 Puckering on both layers only
- 14 Puckering on under layer only
- 15 Shows feed marks on the under side
- 16 Fabric is damaged or holes around the stitches

1.7 Machine fault and how to correct them

The spool thread breaks

The spool thread breaks if the tension is too tight or if the thread is low quality. If the spool thread breaks at the eye of the needle, it must have been thread from the wrong side of the needle or the needle fixed incorrectly.

The machine does not stitch

This happens when the thread is twist around the bobbin. Move the balance wheel back and forth to release the thread. Lift the throat plate and remove the entangled thread. Brush off all the lint and replace the bobbin and make sure that the thread slides out through the bobbin clamp.

The fabric puckers and the threads get pulled

The needle is blunt and needs to be changed.

The stitch length is not consistent

The stitch length varies when the fabric is pulled intermittently. It is important to guide the cloth with a light hand.

The needle skips stitches

This happens if the needle has been placed too high or too low in the needle bar. Check the needle position. The newer models of the sewing machine do not have this problem since the slot in which the needle is inserted is of a fixed size. In case the fault is difficult to handle, it is advisable to consult a competent mechanic.

The needle bends or breaks

The fabric may have been pulled with the needle in it causing it to bend. The bent needle strikes the metal plate around it and breaks. Remember to lift the needle above the surface of the cloth by turning the hand wheel before pulling out the fabric.

1.8 Care & maintenance of sewing machine

A sewing machine needs care for its smooth running. It should be cleaned and oiled regularly to ensure satisfactory sewing and long life. When not in use, your machine should be covered to prevent dust accumulation on it. Use a small dry brush or old toothbrush and soft cloth to remove dust and lint. You should always remove lint deposits, dust and thread bits before oiling any part of the machine. Use a pointed instrument like a needle to pick out the bits of thread and lint that cannot be brushed out.

It is necessary to oil and lubricate the machine periodically. If the machine is used every day, oil and place a piece of folded fabric under the presser foot to absorb any excess oil. To oil thoroughly, remove the upper thread, needle plate, slide plate, face plate, bobbin case, needle and presser foot. Oil the holes on the underside. Use only few drops of oil in each hole. Never use coconut oil. Machine oil of different brands may be used as recommended in the instruction book.

If the machine becomes gummed with oil, put a drop of kerosene or petrol in each oil hole and joints and run it rapidly for several minutes. Wipe off and re-oil it with machine oil. The motor of electric sewing machine should be greased periodically.

Cleaning

Utilize a little dry brush or old toothbrush and delicate fabric to expel residue and build up. You ought to consistently evacuate build

up stores, residue and string bits before oiling any piece of the machine. Use a pointed instrument like a needle to pick out the bits of thread and lint that cannot be brushed out.

Oiling

It is important to oil and grease up the machine occasionally. If the machine is used every day, oil it once every week. After oiling, clean off the surplus oil and place a piece of folded fabric under the presser foot to absorb any excess oil. To oil completely, remove the upper string, needle plate, slide plate, faceplate, bobbin case, needle and presser foot. Oil the gaps on the underside first, in the wake of cleaning and after that continue to the upper side. Utilize just couple of drops of oil in each opening. Never use coconut oil. Machine oil of various brands might be utilized for various models of sewing machine, yet ought to be utilized as prescribed in the guidance book.

If the machine ends up gummed with oil, put a drop of lamp oil or oil in each oil opening and joints and run it quickly for a few minutes. Wipe off and re oil it with machine oil. The engine of electric sewing machine ought to be lubed intermittently.

Check Your Progress II

Q-6 writes about common care of sewing machine

Q-7 Give the solution of thread breaking during sewing.

Q-8 How to solve seam puckering.

Q-9 give reasons for fabric which is not get pulled.

Multiple Choice Questions

- 1) sewing machine is invented in _____.
 - A.1780
 - B. 1785
 - C.1790
 - D. 1795
- 2) sewing machine was invented by _____?
 - A. Thomas cook
 - B. Thomas saint
 - C. Thomas bent
 - D. None
- 3) Function of pressure foot is _____.
 - A. To pull fabric
 - B. To push fabric
 - C. To spread fabric
 - D. To press fabric
- 4) Function of feed dog
 - A. To pull fabric
 - B. To push fabric
 - C. To spread fabric
 - D. (A) (B) both
- 5) How to operate sewing machine?
 - A. Electric
 - B. Hand operated
 - C. Treadle
 - D. All above
- 6) Regular stitch required number on stitch regulator _____.
 - A. 2.5 to 3
 - B. 0 to 1
 - C. 4 to 5
 - D. 1.5 to 2

7) Which part need give pressure to thread for adjusting for stitching?

- A. Pressure foot
- B. Tension disc
- C. Pressure bar
- D. Needle bar

8) Function of needle bar _____.

- A. To hold the needle
- B. To hold the fabric
- C. To hold the stitch
- D. None

9) Function of bobbin case _____.

- A. Structure stitch
- B. To hold bobbin
- C. Hold stitch
- D. All above

1.9 Let Us Sum Up

- Garment making is a technical accomplishment required knowledge of fabric, tricks to stitch and made desirable, comfortable fit so without sewing machine we cannot image how to make beautiful and comfortable garment.

1.10 Key Words

Beneath- lower layer or level

String - thread

Abundance- large quantity

Utilize-useful

Maneuvered- activity, exercises, movements

Luster- shine, glow

Conceivable- imaginable, possible, believable

Insurgency- rising, revolution

1.11 Suggested Books

1. Reader's Digest "Complete Guide to Sewing"

2. Singh, A & Bhardwaj, k (2012 “Textbook of clothing”, vista international publishing house, Delhi) First Edition
3. Patel, V (2016 “Sewing technology”, Sunrise Publication Co., Rajkot)
4. Dhruv publisher (2016-2017“Sewing Technology and Dress Making” Ahmedabad) First Edition

Answers

Check Your Progress I & II

1.

Hand operated sewing machine	Treadle sewing machine
<ul style="list-style-type: none"> • This sewing machine is straight forward machine it is operated by Hand. • A separable handle gave to the flywheel is utilized to work the machine. • For rotating of sewing machine handle is required 	<ul style="list-style-type: none"> • This machine is likely to be hand sewing machine and it operated by feet. • it is worked by foot utilizing an extra remain in this sort the parity wheel. • For rotating of treadle sewing machine belt is required

- 1 The function of presser foot is holding the material solidly in position when brought down.
- 2 The function of stitch regulator is to the regulate the stitch length and it control size of the stitches
- 3 The function of thread take up lever is up and down motion feeds the thread to the needle and tightens the loop formed by the shuttle and loosening the top thread to complete the stitch. And function of needle bar is to hold the needle in right position.
- 4 Sewing machine is crafted by Englishman Thomas Saint in 1790, the sewing machine has significantly improved the effectiveness and profitability of the garments business. The information of sewing give a certain inclination when it is connected to the development of pieces of clothing. The prior technique for sewing by hand isn't appropriate for all phases of article of clothing making. In this manner, significant accentuation is given to machine sewing. There are a few machines in the market today's.
- 5 The Common care of sewing machine given below:
 - To kept sewing machine free from dust and lint.

- To oil the sewing machine regularly.
- To maintain the speed of sewing machine while stitching the cloth.
- To thread properly.
- To kept needle properly while sewing cloth.

7 The thread breaking solution given in below:

- To check tip of needle
- To release or tight the tension disc
- To place bobbin properly in bobbin clamp

8 The needle is blunt so correct it.

9 when feed dog is blunt fabric get pulled. So replace the feed dog.

Multiple Choice Questions

1 (C) 2 (B) 3 (B) 4 (D) 5 (D) 6 (A) 7 (B) 8 (A) 9 (D)

UNIT 2 COMMERCIAL MACHINES FOR SEWING, CUTTING & FINISHING

2.0 Objectives

2.1 Introduction

2.2 Different Types of Sewing Machines

2.3 Sewing Machine Shapes

2.4 Types of Sewing Machines Using In Industry

2.5 Types of Cutting Machines

2.6 Types of Pressing Equipment

Check Your Progress

Multiple Choice Questions

2.7 Let Us Sum Up

2.8 Key Words

2.9 Suggested Books

Answers

2.0 Objective

- In this unit, students will be able to learn, basic information about types of industrial sewing machines along with their uses.
- To understand cutting and pressing machineries and how to work in industry

2.1 Introduction

The predominant procedure in garment assembly is sewing. A great part of the use of technology to apparel production is thus concerned with the achievement of satisfactorily sewn seams. A sewing machine is a machine used to stitch texture and different materials together with thread.

The middle procedure in the assembling of garments is the association of segment tasks that include sewing in some structure. Although there is a wide range of sewing machine, their real sewing capacities are altogether taken from a similar segment portion of sewing.

Industrial sewing machines, by contrast, are bigger, faster, more complex, and more varied in their size, cost, appearance, and task.

2.2 Different types of sewing machines

A side from the above classification, with control there are three types of sewing machines:

Manual Control: The operator controls manually, all phases of sewing cycle. This machine is commonly utilized by little scale industries.

Semi-Automatic Sewing Machines: Machines in which the sewing phases of the operation is controlled automatically by the machine after the operator actuates the machine, for example, buttonhole machines, bar takers, button sewers, dart sewers, pocket sewers, etc.

Automatic Sewing Machines: In these machines the operator simply loads a material in the machine with a pile of garment parts and the machine automatically picks, positions, sews, extracts and discards of the sewed pieces.

2.3 Sewing machine shapes

In fashion manufacture the machines are still mostly utilized in their fundamental structures yet for some specific garment and those made in higher volume. Varieties in machine shape are available which enable simpler development of the materials around the machine. These varieties primarily affect the shape of the bed of the machine, for example the part on which the material rests. The best-known version is the flat bed and the main alternatives are:

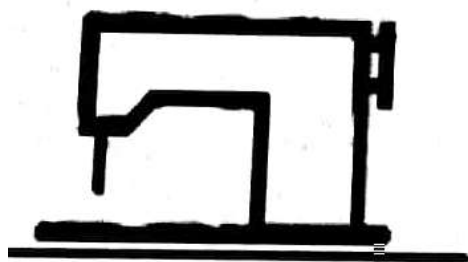

Flatbed (fig-1)

- **Flatbed:** Is used in most of the simple sewing.
- **Cylinder bed and Post bed:** are used where the parts to be sewn are small, curved. And also sewing awkward part of foot wear.

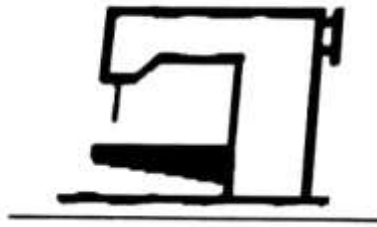

Cylinder bed (fig-2)

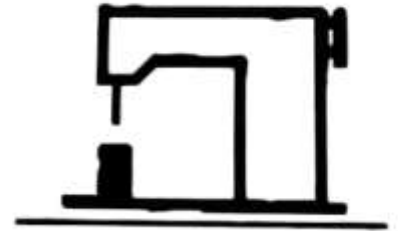

Post bed

(fig-3)

- **Feed-off-the arm:** Machine is utilized where a lapped seam must be closed in such a way that the garment part turns into a tube. They are basic in pants production where the outside leg seam is regularly a lap-felled and it is joined after inside leg seam in the grouping of development.

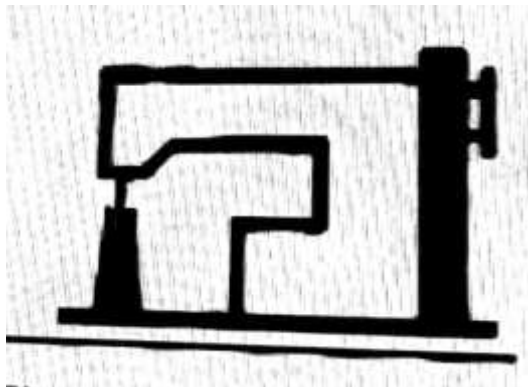

(fig-5)

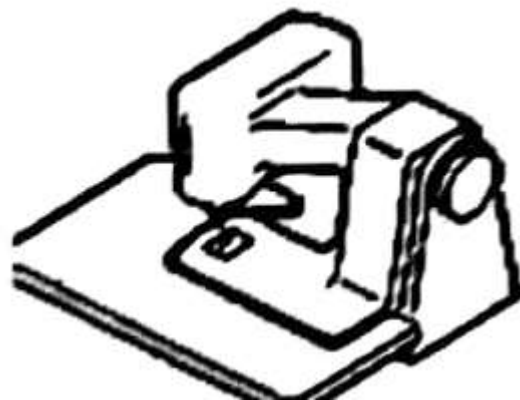

Feed off the arm (fig-4)

Blind stitch

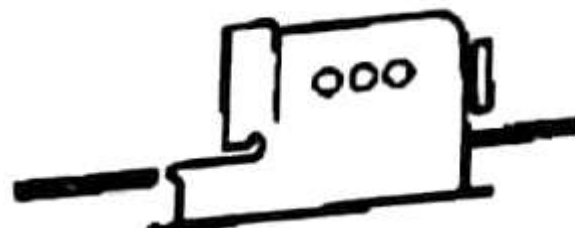

Over edge (fig-6)

2.4 Types of Sewing Machines using in Industry

Sewing machines can make an incredible variety of plain or designed stitches. Ignoring carefully decorative aspects, more than three dozen stitch arrangements are officially recognized by the ISO 4915:1991 standard, including one to seven separate threads to form the stitch.

2.4.1 Lock stitch Machine

The cutting-edge general sewing machine with a needle lock-stitch system is the basic sewing machine.

The features of the machines in common use in today are:

1. Speed of up to 6000 rpm with electronic controls which reduces the time required for increasing speed and deceleration.
2. Automatic positioning of the needle in an up or down position
3. Automatic positioning of top needle and bottom threads.
4. Bar tacking mechanism activated however the foot pedal or naturally by methods for an electronic seam end sensor.
5. Programmable sewing sequence by means of a small-scale processor for respective operations.

Usage

The normal sewing machine is regularly viewed as an end instead of as a basic sewing tool. There is a huge variety of feed types, connection and device accessible to make this machine into one of the most adaptable things of equipment in the sewing room

2.4.2. Over Locking Machines

This is the generic name given to over edge stitch machines used to trim and cover the rough edges of the fabric in order to perfect and flawless appearance where seam edges are visible. Over lock machines are additionally utilized for the assembly of some types of knitted articles, for ex: T-shirts.

Over lock stitches are characterized in various ways. The most basic classification is by the quantity of threads utilized in the stitch. Industrial over lock machines are commonly made in 1, 2, 3, 4, or 5 thread arrangements.

Each of these formations has unique uses and benefits

1. 1-thread: End-to-end seaming of piece goods for textile finishing.

2. 2-thread: Edging and seaming, particularly on knits and woven, completing seam edges, sewing flat lock seams, sewing elastic and lace to undergarments, and hemming. This is the most well-known kind of over lock stitch.

3. 3-thread: Sewing pin tucks, creating narrow rolled stitches, completing fabric edges, decorative edging, and seaming knit or woven fabrics.

4. 4-thread: Decorative edging and getting done with, seaming high-stress places, safety stitches which make additional strength while retaining flexibility.

5. 5-thread: In clothing manufacturing, safety stitches using 2 needles make a solid seam. For each 1 cm of seam length you would require 20 cm of string to sew it.



Over lock stitch machine (fig-7)

The features of over edge stitch machine are

1. Speeds of up to 8500 rpm
2. Automatic thread clipping
3. A vacuum system for separating fabric waste and thread ends.
4. Variable feeds for sewing problem materials.
5. Creating continuous or irregular fullness on the top or bottom when joining two layers.

Over lock stitches are traditionally used for edging and light seaming. Other applications include,

1. Flat locking
2. Edging emblems

3. Pearl stitching
4. Rolled hemming
5. Decorative edging

2.4.3. Safety Stitching Machine

Safety sewing machines have the same features as over lock machines and are utilized for the all the while seaming and over locking of many garments where there is no need for pressed open seams. There are two types of safety stitch machines in general use, the main difference between them being the quantity of threads used to develop the stitching, which comprises of locked chain line parallel to an over locked edge.



Safety stitch machine (fig-8)

Features of safety stitch machine are

1. With the four-thread machine, one of the looper threads of the over lock stitch is utilized as the bottom thread for the chain stitch.
2. On a five-thread machine, each row of stitches has its own threads for example three for the over lock and two for the chain stitch.

2.4.4 Blind Stitching Machine

These machines are utilized for fastening hems or facings as the name suggests, they play out this activity without the stitch impressions appearing on the correct side of the garment. This class of machine utilizes a curved needle which is designed to slightly penetrate the surface of the fabric but rises on a similar side as it enters.

Most blind stitch machines are fit with an optional skip stitch device which device causes the machines get the outside layer.

The special features are

1. Sewing speeds of up to 2000 st/min
2. Automatic thread cutting
3. Automatic needle situating
4. Pneumatic opening and closing of the work plate
5. One or two thread versions are available and with the two-thread machine the stitch is secured in order to prevent unravelling.



Blind stitch machine (fig-9)

Uses

1. Hemming of fine fabrics
2. Sewing machines can make a stitch that appears nearly invisible by utilizing a blind stitch setting and a blind stitch foot.
3. Blind-stitch are commonly used to complete hems of appliqué designs on fabric.

2.4.5. Buttonhole Machine

A buttonhole is a straight or shaped slit cut through the garment and after that sewn round its edges to prevent fraying and stretching. The cut shape of the buttonhole and the number of threads used to cover its edges depend upon the garment type and quality.



Buttonhole machine (fig-10)

Features

1. Where standard kind of garments, for example, shirts are being produced, the buttonholes are automatically sewn and spaced at pre-determined separation.
2. The operator simply positions the work in the machine and starts the cycle.
3. An unloading device removes and stacks the sewn work after completion of the cycle, which enables the operator to work on more than one buttonholing units in time.

Buttonhole machine Uses

Utilized for sewing various kind of buttonholes on pants, shirts and custom fitted coats and coats.

2.4.6. Bar Tacking Machine

The bar tacking machine has many applications in the clothing industries; one of them is the sewing of a dense tack over the open part of the buttonhole.

The machine sews a few stitches over the end of the buttonhole, and then over sews them at right points with a series of covering stitches. Each machine sews fixed number of stitches with a choice to change stitch thickness and machines are available which sew bar tacks containing from 18-42 stitches. Belt loops of pants can also be bar attached with these machines.

The other features available are

1. A system, which signal audibly and visually when the bobbin thread is beneath a specific level.
2. Automatic thread cutting
3. 2-stage pedals which opens and shuts the work clamp and furthermore works the machine.
4. A brake wheelbase, which enables the machine to be easily moved.

In other variants, bar tack machines are utilized for sewing little decorative tacks and shapes.



Bar tacking machine (fig-11)

Features

1. Bar tacking is a type of support sewing utilized by the texture and material industries to fortify emphasizes focuses in garments, sporting, equipment, uniforms and a host of other products.
2. The bar tack stitch is a tight zigzag pattern repeated oppositely over itself a few times to make sewn items stronger, and resistant to tears or rips in the seams.

Uses

1. Reinforcing areas of stress on clothing, for example, pocket openings, bottom of a fly opening or buttonholes
2. In a denim industry, it is frequently utilized in differentiating shading, for example, orange or white.
3. Bar tacking ensures that the seams won't fray or part while the equipment is being used
4. Bar tacking guarantees durability of product

2.4.7. Button Sewing Machine

Buttons with two holes, four holes or shanks would all be sewn on a similar machine by simple modification to the button clamp and the dividing component. The sewing activity comprises of a progression of parallel stitches whose length is equivalent to the spacing between the centres of openings. The needle has a vertical development and the button is moved from side to side by the button clamp. Buttons can be sewn on with one or two threads. Commonly decorative buttons will be sewn on with a large portion of the quantity of fasteners utilized for utilitarian buttons.

Features

1. Each machine has a greatest number of stitches for example 16, 24 or 32 and can be adjusted to sew everything or half for example 8 or 16, 12 or 24, 16 or 32.



Button Sewing Machines (fig-12)

Uses

1. Button sewers are frequently utilized for attaching various types of buttons, for example, four-hole, two-hole, and shank buttons to various garments.

2.4.8. Label Sewing Machine

Variety of label sewers are available from those sewing simple zigzag stitches to a pre-decided length on one or two edges of a label to sew around a wide range of shapes and sizes of label. A specially shaped cylinder bed machine is available over which within pocket of a jacket can be passed, empowering jackets to be labelled with a retailers name after the manufacturer.



Label sewing machine (fig-13)

Uses: Can stitch various kinds of labels on clothing.

2.4.9. Others

A variety other short cycle machines are available which can be utilized for attaching hooks, bars, metal badges. These might be programmable type of machines.

Uses

Motifs and many other decorative and functional garment parts can be effectively appended through these machines.

2.4.10 Special Sewing Machines

Aside from the basic general-purpose sewing machines there is also huge range of high-performance special machines that are worked to perform one operation just at a consistently high level of value. The idea behind these machines is to reduce the skill input of the operator. In a perfect world the administrator is just required to feed the machine rather than controlling the operations.

2.5 Types of Cutting Machines

Two basic types of cutting machines

1. Continuous
2. Intermittent

The major continuous types are

1. Band knife machines
2. Vertical blade reciprocating cutting machines
3. Rotary blade cutting machine

The major intermittent types are

1. Drills
2. Shears
3. Die cutters: clickers and presses
4. Cutting knives: short knives & table sword knives
5. Notches

Advanced types are

1. Laser cutting
2. Plasma cutting
3. Die cutting
4. Water jet cutting
5. Ultrasonic cutting
6. Press cutting
7. Computerized cutting



Round Knife (fig-14)

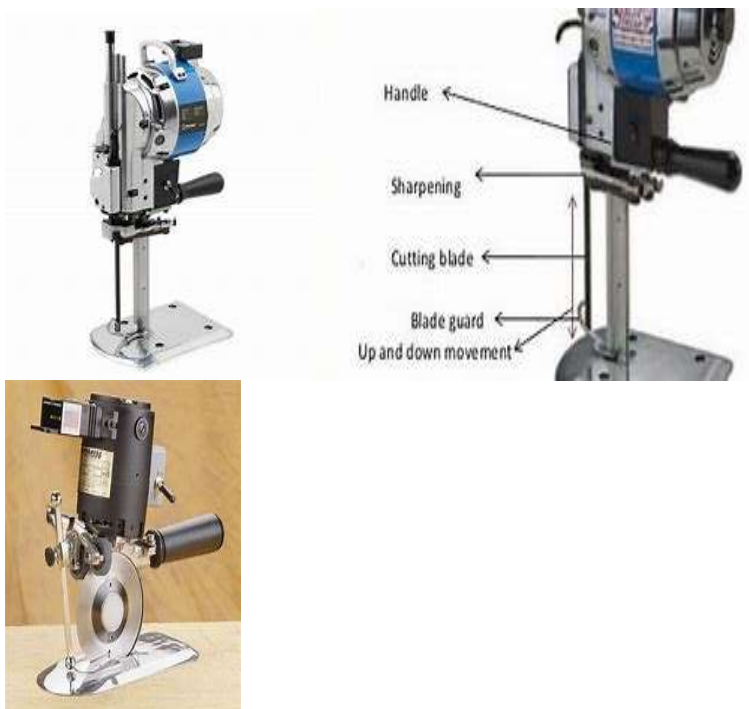

Straight Knife (fig-15)



Band knife (fig-16)

2.6 Types of Pressing Equipment

The basic process that are involved can be divided into two groups

- I. Under Pressing: This is the term used to portray the pressing activities performed on pieces of clothing they are made up.
- ii. Top Pressing: This refers to the completing activity, which clothing undergoes after being totally assembled.

The various pressing equipment used in apparel manufacturing are as follows

Classification of Pressing Equipment: Since, the creation of the first mechanically operated pressing machine in 1905, there had been an endless improvement of squeezing gear. Today one noticeable manufacturer of this equipment lists more than 500 unique kinds of general and specific reason machines extending from those for one simple activity to mix machines fit for performing every operation required for pressing a man's coat. These machines are sorted in three major categories.



Steam pressing (fig-17)

I. Solid Pressure Equipment (Pressing Equipment)

1. Pressing Irons
2. Buck Presses
3. Mangle Presses
4. Block Presses
5. Form Presses
6. Pleating Presses
7. Creasing Machines: Edge Folders

II. Moisture Pressure Equipment (Steaming and Wetting)

1. Wetting Tanks: London Shrinkers & Auxiliary Equipment
2. Sponging machines
3. Decaters
4. Steam Guns & Jets
5. Steam Chambers
6. Autoclaves.

III. Heat Energy Equipment (Heating & Baking)

1. Thermo Electric Machines
2. Hot Plates
3. Casting Equipment
4. Dry Heat Ovens

Check Your Progress

1. What is label sewing machine?

2. Which machine used for sewing shank buttons?

3. Describe the uses of bar taking machine.

4. Enlist types of cutting machine.

5. Enlisting different types of sewing machine shapes.

6. Write about buttonhole machine.

Multiple Choice Questions

1. These machines which are used for fastening hems or facing is _____
(A) Safety machine
(B) Blind stitch machine
(C) Over lock machine
(D) None
2. Which kind equipments used in pressing in garment?
(A) Steam irons
(B) Vertical pressing system
(C) Dry Heat Ovens
(D) All
3. _____ is a cutting machine type.
(A) _____ Cutter
(B) _____ Band knife
(C) _____ Flatbed
(D) A and B both
4. The overlook machine stitch is _____ thread formation.

- (A) 1
 - (B) 2
 - (C) 3
 - (D) All
5. Buttonhole machine used for _____ garments.
- (A) Tops
 - (B) Kurtis
 - (C) shirts
 - (D) None

2.7 Let Us Sum Up

Commercial sewing machines as the name recommends are utilized by industries for large manufacturing of clothing. Sewing machines are invented during the primary mechanical revolution; the sewing machine is instrumental in almost all the commercial garments we wear. By taking a huge manual sewing process, the sewing machine enabled the material business to take off additional time. Sewing machines could be divided into many subtypes. This part manages various kinds of sewing machines alongside their uses.

2.8 Key Words

Actuates-activates

Pile-pile, stack

Adaptable- adjustable, flexible

Unravelling-resolving, break down

Dense-thick

Empowering-enabling

2.9 Suggested Books

<https://www.onlineclothingstudy.com/2017/03/different-types-of-industrial-sewing.html>

<https://fashion2apparel.blogspot.com/2017/01/methods-equipments-garment-pressing.html>

Answers

Check Your Progress

1. Sewing label machine are available from those sewing simple zigzag stitches to a pre-decided length on one or two edges of a label to sew around a wide range of shapes and sizes of label. A specially shaped cylinder bed machine is available over which within pocket of a jacket can be passed, empowering jackets to be labelled with a retailers name after the manufacturer.

2. Button with shanks would all be sewn on a similar machine by simple modification to the button clamp and the dividing component. The sewing activity comprises of a progression of parallel stitches whose length is equivalent to the spacing between the centres of openings. The needle has a vertical development and the button is moved from side to side by the button clamp. Buttons can be sewn on with one or two threads. Commonly decorative buttons will be sewn on with a large portion of the quantity of fastens utilized for utilitarian buttons.

3. Uses of bar tacking machine

- Reinforcing areas of stress on a clothing, for example, pocket openings, bottom of a fly opening or buttonholes
- In a denim industry, it is frequently utilized in differentiating shading, for example, orange or white.
- Bar tacking ensures that the seams won't fray or part while the equipment is being used
- Bar tacking guarantees durability of product

4. There are two types of cutting machine.

1. Continuous

2. Intermittent

The major continuous types are

1. Band knife machines
2. Vertical blade reciprocating cutting machines
3. Rotary blade cutting machine

The major intermittent types are

1. Drills
2. Shears
3. Die cutters: clickers and presses
4. Cutting knives: short knives & table sword knives
5. Notches

Advanced types are

1. Laser cutting
2. Plasma cutting
3. Die cutting
4. Water jet cutting
5. Ultrasonic cutting
6. Press cutting
7. Computerized cutting

5. Different types of shape

1. Flatbed
2. Cylinder bed

3. Post bed
4. Feed - off -the -arm
5. Blind stitch
6. Over edge

6. Buttonhole machine is a straight or shaped slit cut through the garment and after that sewn round its edges to prevent fraying and stretching. The cut shape of the buttonhole and the number of threads used to cover its edges depend upon the garment type and quality.

Multiple Choice Questions

1.(B) 2. (D) 3. (B) 4. (D) 5. (C)

UNIT 3 SEWING TOOLS AND EQUIPMENTS

3.0 Objective

3.1 Introduction

3.2 Importance of Sewing Tools

3.3 Care and Maintenance For sewing tools

3.4 Measuring Tools

3.5 Drafting Tools

3.6 Marking Tools

3.7 Cutting Tools

3.8 Stitching Tools

3.9 Pressing Tools

3.10 General Tools

Check Your Progress

Multiple Choice Questions

3.11 Let Us Sum Up

3.12 Key Words

3.13 Suggested Books

Answers

3.0 Objectives

- To make understand students about sewing tools and equipment's identification
- To Give the knowledge about function and use of sewing tools and equipment
- To make them aware regarding use of sewing tools and equipment

3.1 Introduction

A Sewing tools and equipment are required for sewing which help in development of pieces of clothing of good quality and appearance. The sewing tools are classified into different category according to their sequential work step by step such as measuring, drafting, marking, cutting, sewing and finishing. Here in this chapter we would discuss about measuring, drafting and marking tools, which are used before cutting and sewing of garments. A measurement is an important activity which concern with the person who wants to stitch his or her own garments. Marking and drafting of garment is another activity which gives proper guidance and direction for such garment which is going to cut and sew. For performing these activity different kinds of tools are involved.

3.2 Importance of Sewing Tools

- The importance of sewing is having a skill that can allow creativity, saves money by repairing, and can also be relaxing.
- Always keep your cutting tools clean. Wipe each of them with a clean dry soft cloth, if you feel it is dirty or has lint on it
- Keep them in their casing when not in use. These tools are sharp if can harm kids and pets if not stored safely.

3.3 Care and Maintenance for Sewing Tools

- Keep your measuring tapes rolled up, to avoid them getting tangled.
- Always use needles of the proper size for the fabric.
- Always use sharp good quality needles
- Never cut anything with your sewing scissors. If you need to cut paper, get a cheap pair of scissors, but don't use the sewing scissors.
- Iron: Keep it stored in a cool, dry place where it can't fall or get knocked into. Keep the cover on it.

3.4 Measuring Tools

1. Measuring tape: It has a smooth surface and usually measures about 60 inches long and 5/8 inches wide, which is clearly marked of inches and centimeters on both sides. Because of its flexibility it is must have tool for taking accurate body measurements. At one end of the tape is attached to brass strip about 3 inches long and at the other end, a small brass covering. A flexible measuring device used in taking body measurements. The front has the measurement of 150 centimeters and 60 inches on the other side.



Measuring tape (fig-1)

2. Measuring stand: It is mostly useful in overcoat, lady's night wear, and to measure wide cloths.

3. Metal tape: Metal tape is used in sharp shapes.

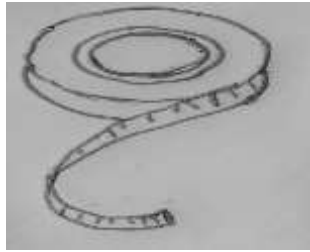

Metal tape (fig-2)

4. Rulers: A ruler measuring 12 inches and 18 inches, either clear or solid. It is a useful tool to have for measuring and drawing straight seam lines and cutting lines. It also use in connecting lines. A clear ruler is also a good tool for marking buttonholes. Rulers, plastic or acrylic with easy to read marking is helpful when measuring and drawing straight seam line and bias line.



Rulers (fig-3)

5. Yardstick or meter scale: yardstick useful for checking grain lines. It is in 36 inches or 45 inches long, and is made from wood or metal material.



Yard stick or meter scale (fig-4)

6. L scale: It is an L-shaped metal ruler; the long arm measures 24 inches, and short arm 14 inches. This has a perfect right angle corner and is used to draw lines at right angles at the time of drafting. It is helpful during the process of 'straightening fabric' to check whether the corners of the fabric have got the right-angled structure or not. It used for marking hemlines and checking grain lines when laying out the pattern. It is made up of wood or metal.

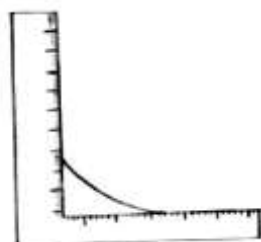

'L' scale (fig-5)

7. Hem Marker: It is used for marking out a completely level hem line in chalk. It can be adjusted to any hem length. This is commonly used for professional hem marking.



Hem marker (fig-6)

8. Dress maker's gauge: It has one side straight border line and the other side frilled border line where the straight border has 1", 2", 3", 4" measure. Normally frilled border line used for measuring pleats and fold, and straight-line use for measuring buttonhole.



Dress marker's gauge (fig-7)

9. Seam gauge: Seam gauge is 6" long, used for measuring short spaces. It is metal scale, marked in both inches and centimeters with sliding pointer. It is used to mark hems for button, buttonholes length as well as intervals between pleats.

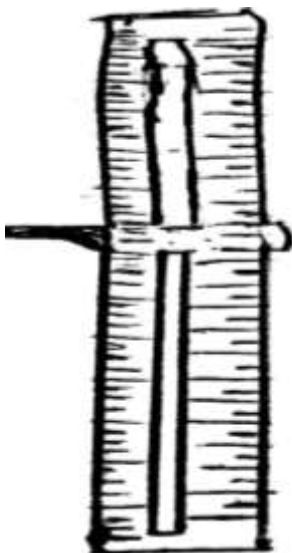

Seam gauge (fig-8)

10. Card scale: They are made from paper cardboard generally used for small drafting in some record on notebook.



Card scale (fig-9)

11. Measuring stick: It is flexible stick and it's used to check fabric fibers and correct border line marks.

12. Set square: Set square is a triangular piece of transparent plastic mostly used for design and pattern.

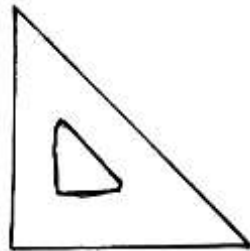

Set square (fig-10)

13. T-square: A T-square is used primarily as a guide for drawing lines it may also guide a set square to draw vertical or diagonal lines and to correct right angles.

3.5 Drafting Tools

Drafting tools are helpful to fix the pattern, draw, draft and cut the pattern as well as fabric. The following tools will be used for this purpose.

1. Wooden Table: A level board put on a table where the fabric is spread out and cut. The fabric can be stuck safely to the cutting board/table to keep it from slipping. Wooden table is 3 feet width and 5 feet in length is a desirable size of the table and the height can be around 2.5 feet.

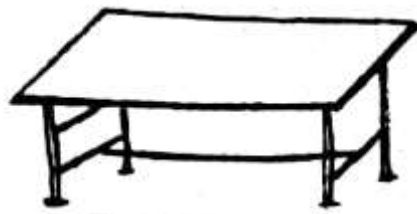

Wooden table (fig-11)

2. Brown Sheet: Brown sheet is helpful to draft paper design on a Brown sheet with right body measurement than drafting and cutting directly on the texture. The pattern is pinned over the texture, marked and afterward sewed in the wake of cutting, which will prevent wastage of texture. Hence for drafting such pattern brown sheet is necessary.

3. Dress form: Dress form is used to check clothes fitting. When making garment it can be put on dress form so we can see the fit and drape garment. Dress form comes in all shapes and sizes. Dress form is a three-dimensional model. The measurement of the dress form must be same as the measurement of the wearer for whom the dress should be made. Rather than taking measurement from the model or individual, the dress which suits well and fits accurately can be utilized as a guide for measurements.

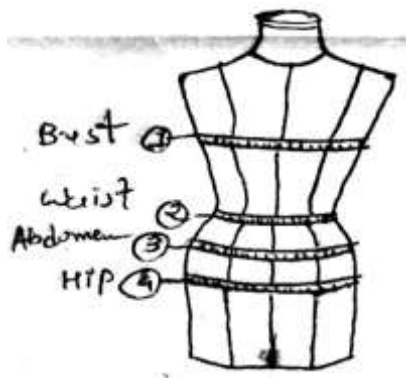

Dress form (fig-12)

4. Bell pin: Use of pins for treating and fixing of pattern pieces to the texture makes work simpler, faster and progressively exact. Select sharp thin medium extensive pins that won't leave pin marks, on a wide range of textures. For silk, satin and other shaky, tricky textures pattern must be pinned to the texture before cutting. Pins come in different sizes to use in different fabrics. The right choice of pins is most essential for good workmanship, speed, and convenience in sewing pin should be of stainless steel. Use silk for fine knits. The other types of pins are dressmaker pin (a pin of medium diameter but quite suitable for most sewing needs), and silk (a very slender pin with a needle point to be used on delicate fabrics).

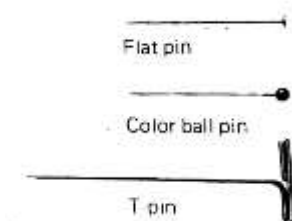

Bell pin (fig-13)

5. Pin cushions: Pin cushion is a small attractive cushion which is used in sewing to store pins and needle. Attractive pin cushion can be made at home by using soft fabric and filling in cotton. These are accessible in a

wide range of styles; some have an elastic or plastic band so they can be worn around one's wrist. Continuously utilize a pin cushion to hold the pins while work. This will prevent the disappointment of spilling an entire box of pins on the table or floor, and the possibility of swallowing a stick.

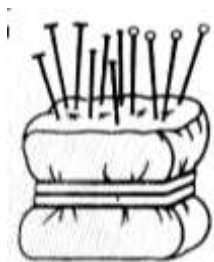

Pin cushion (fig-14)

3.6 Marking Tools

This is also called as Tailor's Chalk. As color pencil, this is also utilized for checking seam lines and other pattern details on textures as a guide in sewing. This is available in assorted hues in rectangular and triangular shapes. This can be chosen by the texture color. The edges can sharpen for drawing straight and curved lines easily.

1. Tracing paper: Tracing paper is useful for developing design. and creating drawings. It is also useful for duplicating designs from. The main source the design creating on tracing paper will use to transfer design to the fabric in and trace one and opposite direction.

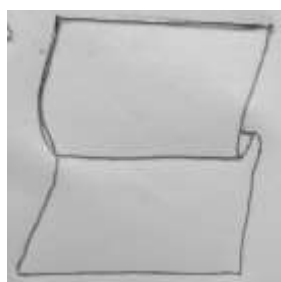

Tracing paper (fig-15)

2. Tailor's chalk: Tailor's chalk available in hard form. These are also available in various colors and in rectangle or triangular shapes. Use those which have a fine edge for accuracy in marking. Tailor's chalk rubs off easily and can be used specially to mark on the right side of the fabric.



Tailor's chalk (fig-16)

3. Tracing wheel: These can be used to transfer mark on both side of the fabric. It is used to transfer the pattern markings-including seams, darts and pockets placements to the wrong side of the fabric with the aid of tracing paper. The small serrated edge tracing wheel is appropriate for most fabrics. A smooth edge tracing wheel is used on fine or knit fabrics to avoid snagging the yarn. The tracing wheel should be made of steel and have sharp edges. This instrument with multiple teeth on a wheel attached to a handle.



Tracing wheel (fig-17)

4. Pencil: Pencils are generally used for marking, drawing, and drafting. Dress marker pencils are not available, so ordinary colored pencils may be used. Pencils have the advantage of having sharp points which are better for marking darts. These are especially good to mark fine lines on dark fabrics.

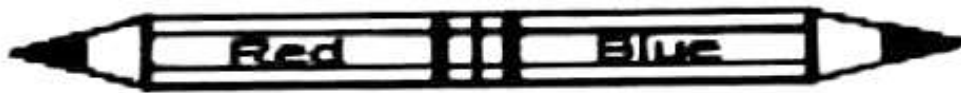

Pencil (fig-18)

5. Friction pen: They are one of my preferred stamping instruments, valuable for moving example scores on to light shaded textures. Perhaps you can discover these ballpoint gel pens on your kids' pencil-case.

6. French curve: It is a thin plastic sheet with profiles of several curves, used for drawing curves in garments.

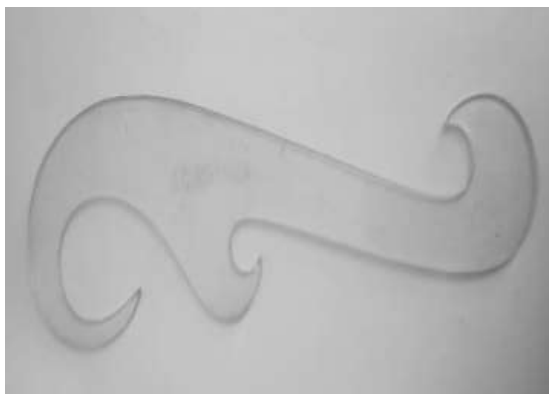

French curve (fig-19)

3.7 Cutting Tools

The following types of shears and scissors are made for both right-handed and left-handed cutting. All cutting tools must be kept sharp, clean and grease-free for accurate cuts. Cutting tools are helpful to cut out the pattern from paper, and to cut the fabrics.

1. Small shears: They are 5 to 6 inches long. They are used for light cutting, trimming, clipping corners, and cutting curves. These have round handles for both the blades. They are designed for snipping threads and trimming seams. They should be held so that the wider blade is above the narrower blade.

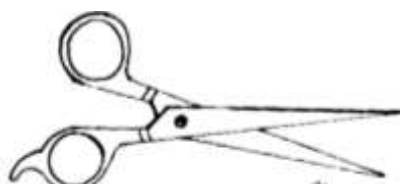

Small shears (fig-20)

2. Tailor's shears: Shears are available in many sizes for normal home sewing the blades should be 7''-8'' long so that they are light and easy to handle and 8''-10'' inches long for cutting all types of fabrics. Shears differ from scissors in that they have one small ring handle for the thumb and a large ring handle for the second, third and fourth fingers. To keep in good condition, wipe the lint after use and oil the rivet occasionally.

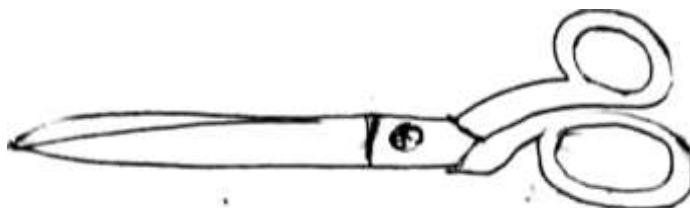

Tailor's shears (fig-21)

3. Cutters: These are usually 3''-6'' in length and are used for clipping threads and for making notches or slashes on the fabrics.



Cutter (fig-22)

4. Buttonhole scissors: Buttonhole scissors are made for making buttonholes without stretching or damaging the garment. You can make different size holes.

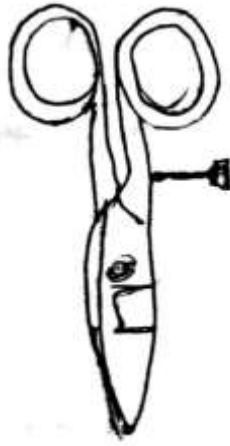

Buttonhole scissors (fig-23)

5. Pinking Shears: Select a lightweight pinking shear. These are helpful for completing the edges of seams and other raw edges of texture. They produce a zigzag cutting line which prevents raveling of woven textures. Pinking gives a slick appearance to the inside of garment.



(Fig-24)

6. Seam Ripper: This is pen formed device with a little sharp blade at one end for removing unwanted stitches. Utilize the blade to lift the string away from the texture before cutting. They come in a various style, colours and sizes.



Seam ripper (fig-25)

7. Embroidery scissors: These are little scissors, just 3" to 4" (7.5-10 cm) long, with pointed sharp edges. Use embroidery scissors for detail work, for example, cutting buttonholes and ripping stitches.

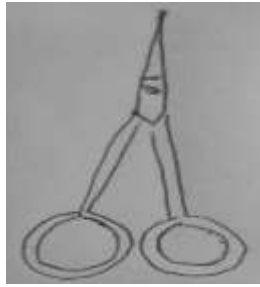

Embroidery scissors (fig-26)

8. Electric Scissors: These are used in most sample rooms. They are ideal for cutting silk, nylon, and soft, hard-to-cut fabric. These are light in weight and easy to operate.



Electric scissors (fig-27)

3.8 Stitching Tools

Stitching tools are used for hand sewing and machine Sewing. Commonly we are used sewing tools are:

1. Fabric: While choosing Fabric, select a decent quality texture, which will be easy to stitch. Learning of different kind of texture, their expense and width of texture, is essential for good sewing.

2. Needle:

Hand needle: They are found in sizes from the fine 9 to the heavy 18. The best quality needles are made of hand ground steel. For hand sewing medium length needles with a short oval eye is chosen. The needles ought to have sharp Points and smooth and well-polished eyes. Sharp and short needles are reasonable for permanent sewing, Ball point needles are utilized to sew fine silk or polyester knits. Crewel needles are intended for embroidery work which have a long oval eye and are thus effectively threaded.

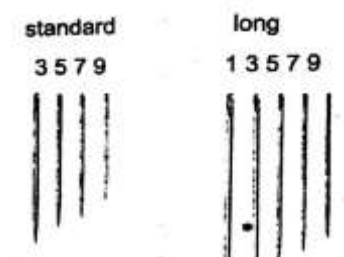

Hand needle (fig-28)

Machine needle: There are many types of needle having different use. Earliest needles were made of wood or bone modern needles are manufactured high quality steel wire. The best quality needles are always essential for good sewing. Points must be sharp, smooth and well-polished for quick sewing. Select needle according to type of stitches. Long needles utilize for darning. (Size no.6 or no.7). Ordinary needle is utilized for stitching normal stitches and for tacking.

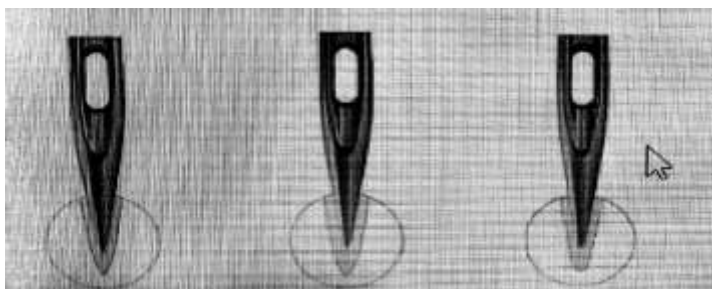

Sharp point regular round point light ball point

(fig-29)

Sharps needles: Sharp needles are used for normal hand sewing. It is built with a sharp point, and a round eye and it has medium length. While minimizing fabric friction it can carry two strands of thread because sharp needles have double eyes property.

Regular round point:

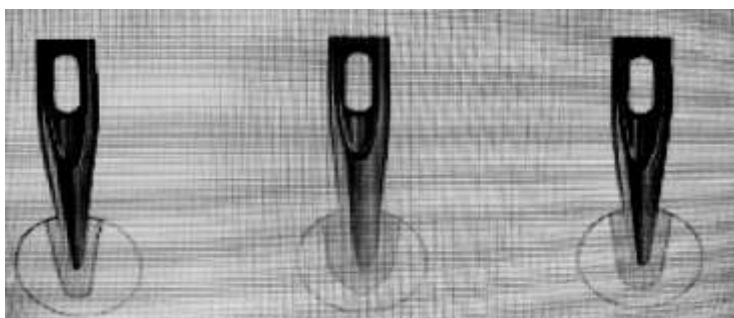

Medium ball points special ball point heavy ball point

(fig-30)

Blunts and between: These are shorter than sharps with the small rounded eye used by tailors work on heavy fabrics.

Crewels: Crewels are known as also hand embroidery needles. It is in a medium length hand needle with sharp point and long eye for multiple or thick yarn.

Milliners: Milliners needle are longer than sharps needle, they are useful for basting or pleating work. And used in millinery work.

Bodkin: It is also called as ballpoint. This is a long and thick needle with large eyes. it can be flat or round. It is generally used for elastic or ribbon

thought casting and its round tip used for pushing out the corner of stitched garment.

Tapestry needles: Tapestry needles are thick; with large eyes which can carry heavier weight yarn like wool than other needles they can pass through loosely woven fabric such as embroidery.

Tatting: Tatting needles built with long and even thickness for their entire length. Their eye are also having same thickness, to enable thread.

Sail maker: they are used for sewing canvas and heavy leather it is similar to leather needle, but the triangular point extends further up the shaft.

Parts of sewing machine needles:

- Shank
- Shoulder
- Shaft
- Groove
- Scarf
- Eye
- Point

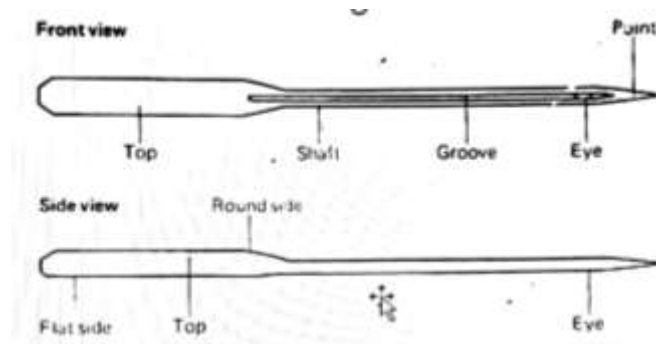

Machine needle (fig-31)

3. Thread: For sewing, select string from spool or reel of good quality from a dependable brand, to match with texture in different color and sizes. Different kind of strings like cotton, silk, and nylon threads are accessible in the market.



Thread (fig-32)

4. Thimble: Thimble is worn on the middle finger while pushing it through thick fabric it is called the dress maker thimble too. There are two types of thimble; open-ended thimble and closed-ended thimble open ended thimble used by tailors. It allows them to manipulate the cloth more easily. Metal thimble is ideal. Select a non-rust, light weight thimble. Thimble is protecting to the finger.

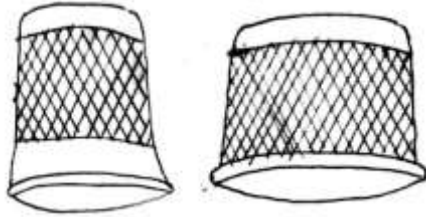

Thimble (fig-33)

5. Needle threader: Needle threader is a small device which can help us to put thread through the eye of needle. The Victorian designed needle threader is famous now a day. The user passes the wire loop though the needle eye, passes the string though the wire loop and pulls both the loop back though the needle by the handle.

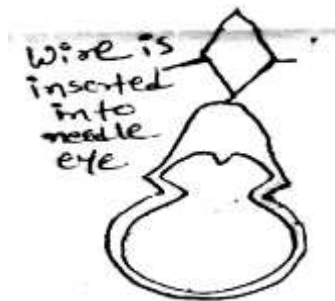

Needle threader (fig-34)

6. Bodkin: This gadget resembles a large, blunt needle and it utilized to force cord, elastic, tape, or lace through castings. This is a flat needle with blunt end and a huge eye, utilized for stringing lace or elastic through a tunnel or eyelet casing.

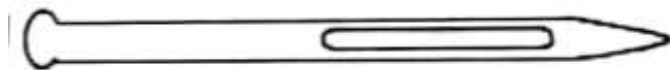

Bodkin (fig-35)

7. Loop turner: This tool is a long metal rod with a hook at one end used to turn bias tubing right side out.



Loop turner (fig-36)

8. Presser feet: There are a few unique kinds of presser feet. For general use, utilize the multi-purpose presser foot. One of the most well-known feet that are utilized is zipper foot to introduce zippers by squeezing just on one side of the needle. It can likewise be utilized to embed funneling, or a beaded trim, frill or at whatever point there is more mass on one side than the other.



Presser feet (fig-37)

9. Bobbin: A bobbin is the part of a sewing machine on which the lower thread is wound up in the bobbin. The machine makes a stitch by catching the bottom part of machine.



Bobbin (fig-38)

3.9 Pressing Tools

Pressing tools utilize for finishing of the garments.

1. Iron: Iron made of steel with Teflon covering alongside customizable controllers is typically best. Texture ought to be free from wrinkles while cutting. Squeezing helps to remove wrinkles, if present. Keep an automatic handy iron for pressing texture before cutting, during development and after the clothing is finished.

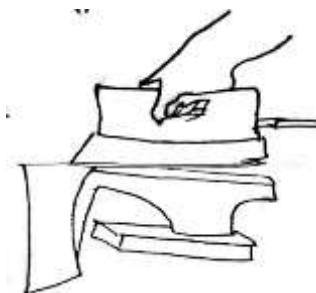

Iron (fig-39)

2. Steam iron: It has a customizable temperature control and is outfitted with a thumb press for programmed steam. Refined water is warmed, and the subsequent steam can be discharged with the thumb press while squeezing.

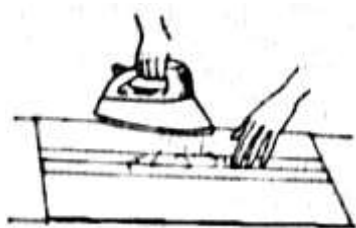

Steam iron (fig-40)

3. Ironing table: It is utilized for hand squeezing; a well-cushioned, molded table of advantageous tallness is excellent. One may utilize a customary table secured with sheet and cover for this reason.



Ironing table (fig-41)

4. Sleeve board: This is a well-cushioned scaled down of a full-sized pressing board; is utilized to squeeze sleeves and difficult to-achieve little subtleties. It has a decreased end on one side and a round end on the opposite side.

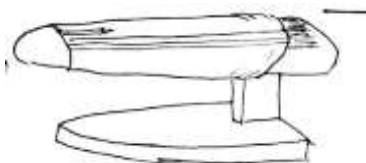

Sleeve board (fig-42)

5. Needle board: Needle board covered with very short fine wires that are used for pressing pile fabrics. Especially design to iron velvet without flattening the pile.

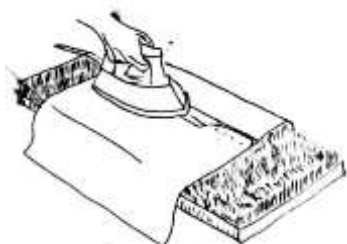

Needle board (fig-43)

1.5.8 Awl

It is a small, sharp-pointed tool used to punch small, round holes for marking in paper or leather.



Awl (fig-44)

6. Lint roller: This is finishing instrument You can utilize it to keep your task clean from bits of string meandering in the wake of utilizing your crease ripper, or on the off chance that you don't have a string catcher.



Lint roller (fig-45)

7. Pressing Cloth: Is a lightweight material that will secure your texture, as far as your rundown of sewing supplies goes this one is shabby as chips and will spare you from having a gleaming posterior or creases.



Pressing cloth (fig-46)

3.10 General Tools

1. Mirror: A mirror is useful for checking the body measurement, fit and design of the garment on model.

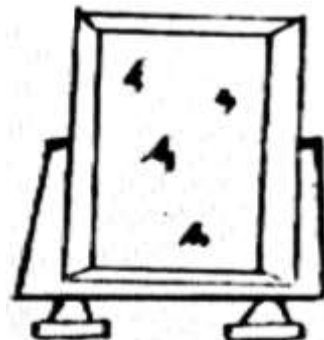

Mirror (fig-47)

2. Interfacing: Sew on – As the name says dainty interfacing is sewn to the texture giving it shape and body Fusible – This sort of interfacing is pressed onto the texture again making body and shape. Interfacing is utilized for molding sleeves, collars, belts, and front of coats. You can buy light, medium or heavyweight in either light or dull hues.

3. Sewing Box: Fills in as a utility box. Sewing instruments like pins, string, thimbles, and others can be kept in this crate. Sewing boxes fluctuate in style, for example, the compartmentalized and non-compartmentalized box. A compartmentalized sewing box is reasonable because your apparatuses can generally be systematic orchestrated.



Sewing box (fig-48)

4. Duster: There is normally a little brush that accompanies your sewing machine. You can utilize it to clean build up from the machine or utilize an old toothbrush.

Check Your Progress

1. Enlist measuring tools and write about any three tools.

2. Write about importance Tools.

3. Write about Marking Tools.

4. Write about different kind of drafting tools

5. What is Scissors?

6. How to maintain tools and equipments?

7. Enlist pressing tools.

Multiple Choice Questions

1. Tools can be stored in this,

- (A) Pin cushion
- (B) Thimble
- (C) Storage Box
- (D) All the above

2. Tracing wheel, if used along with this tool, makes the marking more prominent,

- (A) Carbon Sheet
- (B) Tailors Chalk
- (C) Pins

(D) Pin Cushion

3. Shear is used for cutting.

(A) Paper

(B) Thread

(C) Both paper and Thread

(D) Fabric alone

4. The important tool in taking body measurement.

(A) Scale

(B) Measuring Tape

(C) Tracing wheel

(D) Thread

5. A length of measuring tape is.

(A) 40''

(B) 120''

(C) 90''

(D) 60''

6. To prevent the fingers from needle pricking we must use this tool.

(A) Needle

(B) Scissor

(C) Thimble

(D) Thread

3.11 Let Us Sum Up

The sewing tools and Equipments are broadly classified as Measuring Equipment, Marking Equipment, Cutting Equipment, General Tools, and Pressing Tools. Every classification of instruments has their own purpose in garment development and finishing up. Appropriate choice and utilization require more care as they improve the presence of the completed pieces of clothing and diminish the time taken in their construction.

3.12 Key Words

Swallowing-absorbing

Ordinary- Common

Accessible-available

Diminish- reduce

3.13 Suggested Books

1. Thomas, A, (1993 “The Art of Sewing”, UBS Publisher’s Distributors Ltd, New Delhi, Bombay, Bangalore, Madras, Calcutta, Patna, Kanpur, London)
2. Patel, V (2016 “Sewing technology”, Sunrise Publication Co., Rajkot)
3. Dhruv publisher (2016-2017“Sewing Technology and Dress Making” Ahmedabad) First Edition
4. Reader’s Digest “Complete Guide to Sewing”

Answers

Check Your Progress

1. Measuring tools: 1. Measuring tape 2. Measuring stand 3. Metal tape 4. Rulers 5. Yardstick or meter scale 6. L scale 7. Hem Marker 8. Dress maker’s gauge 9. Seam gauge 10. Card scale 11. Measuring stick 12. Set square 13. T-square

Measuring tape: It has a smooth surface and usually measures about 60 inches long and 5/8 inches wide. That is clearly marked of inches and centimeters on both sides. Because of its flexibility it is must have tool for taking accurate body measurements. At one end of the tape is attached a brass strip about 3 inches long and at the other end, a small brass covering. A flexible measuring device used in taking body measurements. The front has the measurement of 150 centimeters and 60 inches on the other side.

Rulers: A ruler measuring 12 inches or even 18 inches, either clear or solid. It is a useful tool to have for measuring and drawing straight seam lines and cutting lines. It also aids in connecting lines. A clear ruler is also a good tool for marking buttonholes. Rulers, plastic or acrylic with easy to read marking is helpful when measuring and drawing straight seam line and bias line.

Card scale: They are made from paper cardboard generally used for small drafting in some record on notebook

2. Importance of tools

- The importance of sewing is having a skill that can allow creativity, saves money by repairing, and can also be relaxing.
- Always keep your cutting tools clean. Wipe each of them with a clean dry soft cloth if you feel it is dirty or has lint on it

- Keep them in their casing when not in use. These tools are sharp if they are any good and can harm kids and pets if not stored safely

3. Marking tools utilized for checking seam lines and other pattern details on textures as a guide in sewing. This is available in assorted hues in rectangular and triangular shapes. This can be chosen by the texture color. The edges can sharpen for drawing straight and curved lines easily.

4. Drafting Tools

Drafting tools are helpful to fix the pattern, draw, draft and cut the pattern as well as fabric. The following tools will be of use.

- **Wooden Table:** A level board put on a table where the fabric is spread out and cut.
- **Brown Sheet:** Brown sheet is helpful to draft paper design on a Brown sheet with right body measurement than drafting and cutting directly on the texture.
- **Dress form:** Dress form is used for check clothes fitting. When making garment it can be put on dress form so we can see the fit and drape garment. Dress form comes in all shapes and sizes. Dress form is a three-dimensional model.
- **Bell pin:** Use of pins for treating and fixing of pattern pieces to the texture makes work simpler, faster and progressively exact. Select sharp thin medium extensive pins that won't leave pin marks, on a wide range of textures.
- **Pin cushions:** Pin cushion is a small attractive cushion which is used in sewing to store pins and needle. Attractive pin cushion can be made at home by using soft fabric and filling in cotton.

5. Shears are helpful to cutting fabric. Shears are available in many sizes for normal home sewing the blades should be 7''-8'' long so that they are light and easy to handle and 8''-10'' inches long for cutting all types of fabrics. Shears differ from scissors in that they have one small ring handle for the thumb and a large ring handle for the second, third and fourth fingers. To keep in good condition, wipe the lint after use and oil the rivet occasionally.

6. Maintains tools and equipment

- Keep your measuring tapes rolled up to avoid them getting tangled.
- Always use needles of the proper size for the fabric.
- Always use sharp good quality needles
- Never cut anything but fabric or thread with your sewing scissors. Need to cut paper, get a cheap pair of scissors, but don't use the sewing scissors.
- Iron: Keep it stored in a cool, dry place where it can't fall or get knocked into. Keep the cover on it.

7. Pressing tools is 1) iron 2) steam press 3) sleeve board 4) needle board 5) iron table 6) press cloth 7) lint roller

Multiple Choice Questions

1. (C) 2. (A) 3. (D) 4. (B) 5. (D) 6. (C)

UNIT 4 PERMENANT AND TEMPORERY HAND STITCHES

4.0 Objectives

4.1 Introduction

4.2 Preparation before Starting Hand Stitches

4.3 Temporary Stitches

4.3.1 Even Basting

4.3.2 Uneven Basting

4.3.3 Diagonal Basting

4.3.4 Slip Basting

4.3.5 Pin Basting

Check Your Progress I

4.4permanent Stitches

4.4.1 Running Stitch

4.4.2 Hemming

4.4.2.1 Slip Stitching / Blind Hemming

4.4.2.2 Knot Hemming

4.4.3 Backstitch

4.4.4 Run and Back or Combination Stitch

4.4.5 Overcast Stitch

4.4.6 Whipping

Check Your Progress II

Multiple Choice Questions

4.5 Let Us Sum Up

4.6 Key Words

4.7 Suggested Books

Answers

4.0 Objectives

- In this Unit you will, the knowledge of different types of temporary stitches and permanent stitches.
- Understanding the different stitches for suitable garments

- To know how the raw edges of the fabrics are finished by hemming.
- After learning this unit, you will be able to understand the basic knowledge of garment construction in how to be finishing on garment.

4.1 Introduction

There are many hand stitches used in garments and household equipments. Hand stitches have many uses. Before sewing machine, garment making was done by hand stitches. But today many garments sewn by machine. Some garments have different types of hand stitches used in finishing technique

Understanding garment making and normal learning of fundamental sewing procedures, for example, simple stitch, pleats, darts, gathers etc, would empower fitting application in garment development. Before learning to stitch seam on the machine one must gain proficiency with the basic hand stitches which are utilized in garment making.

Basic stitches are divided in to two parts one is construction and second is decorative stitches. Construction stitches are further divided in again two parts one of the permanent stitches and second is temporary stitches.

4.2 Preparation before starting hand stitches

- Using strong thread for hand stitches.
- Use a same colour thread to the garments for hand stitches
- Hand needles arrive in an assortment of sizes and types. For better fabrics, utilize a little needle.
- Use a better needle when short, single stitches are required. Longer needles are preferred when various stitches are to be sewed at once, for example, basting.
- Using thread no longer than 18 to 24 inches. It is always important to select the appropriate thread and needle for the fabric and garments.

4.3 Temporary Stitches

Garments pieces are held together by utilization of temporary stitches, before permanent stitches join are made. These temporary stitches are named as attaching or basting stitches. They help in holding at least two layers of material together before the permanent stitches are made. Normally these stitches are worked in horizontal and from right to left. This is the main stitch which is string with a knot. For attaching, utilize a difference shading threads. The length of stitches will be depending upon the heaviness of the fabric and how safely the pieces must be held together. There are a few kinds of attaching or basting stitches join as given underneath,

4.3.1 Even basting

This is utilized for attaching seams and additional detail. It is a short temporary stitch utilized on smooth texture and in places that require close control, for ex, curved seam. The stitches are of equivalent length about $\frac{1}{4}$ inches on the two sides of the material.

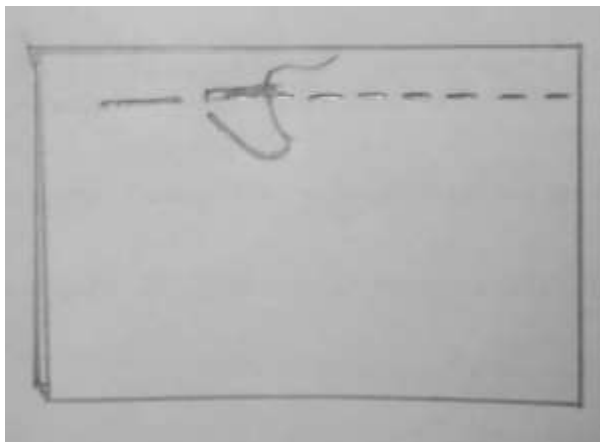

Even basting (fig-1)

4.3.2 Uneven basting

In this stitch on the upper side is $\frac{1}{2}$ " or possibly twice that on the underside ($\frac{1}{4}$ "). It differs from the even basting stitch in that it is short stitch across the back side of the fabric and long stitch across the front. Uneven stitch can be utilized for longer overlays and seams. This is relatively more grounded than even attaching. Utilize this kind of attaching as guideline or where there is short or no strain.

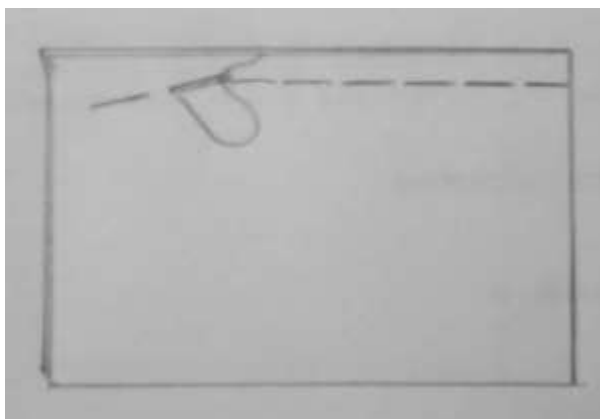

Uneven basting (fig-2)

4.3.3 Diagonal basting

This stitch is utilized when a few layers of textures are to be held safely. Work stitches through the material at right angles to the texture edges with that diagonal or slanting stitches made on the upper side and a little vertical stitch on the underside. The stitch is made about $\frac{1}{4}$ inch separated. Work

stitches through the material at right points to the texture it must not appear through on the correct side of the texture.

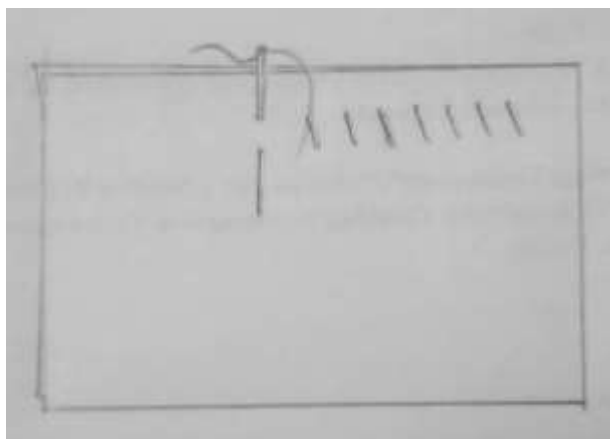

Diagonal basting (fig-3)

4.3.4 Slip basting

This is the frequently utilized while matching seams in checked and striped textures. This is additionally used to bast seam lines that have been fitted from the correct side of the garment. Overlap one seam edge under and stick it over the other seam edge along the sewing line. Presently needle up near the folded edge through the three layers of fabric. As near that point as conceivable go down through the single layer and come up again $\frac{1}{4}$ to $\frac{1}{2}$ inch away through the three layers as before. Proceed till the end. Stitch on wrong side will be slightly diagonal. Little stitches will show up on the correct side.

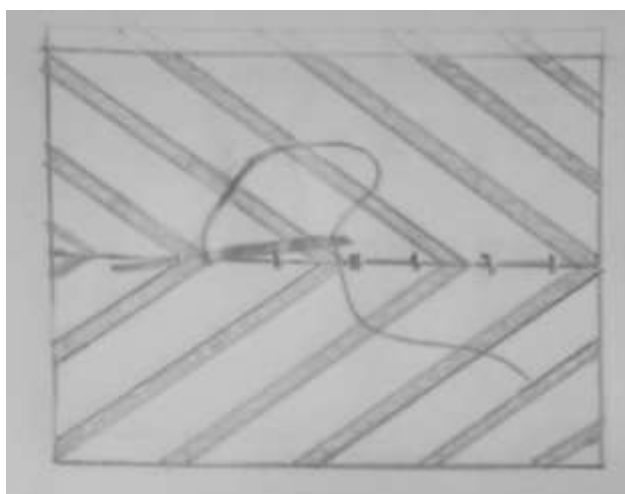

Slip basting (fig-4)

4.3.5 Pin basting

Pin basting is an easy and quick method of basting or tacking with the help of pins. Hold the edges of the fabric together and secure them in place with pins. Place the pins perpendicular to the seam line keeping pin heads towards the seam edge and pin them 2.5 -10 centimetres apart (Fig. 3.5).

Keep pin heads away from the presser foot and machine stitch along the basting line.

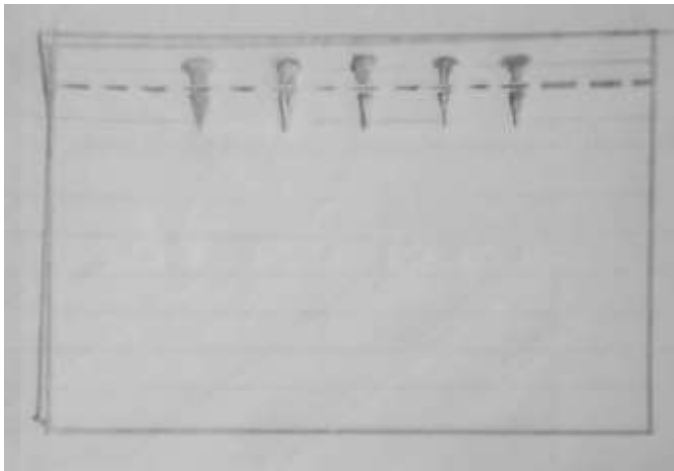

Pin basting (fig-5)

Check Your Progress I

1. What kind of preparation is required before doing hand stitches?

2. Write about use of temporary stitch.

3. Enlist temporary stitch.

4. Difference between even basting and uneven basting.

5. What is slip basting?

4.4 Permanent Stitches

The stitches that are left in the piece of clothing and form a piece of the sewed garment are permanent stitches. Knot is not commonly utilized for beginning the permanent stitches. A few stitches toward the start of a line will be useful in verifying the lines. These stitches are made permanent on the fabrics and need not be removed later like Temporary stitch. Some of permanent stitches are 1. Running stitch 2. Backstitch 3. Run and back stitch 4. Hemming stitch 5. Whipping stitch 6. Over sewing

4.4.1 Running stitch

This is the most straight forward type of hand stitch. It is utilized to join fabric in the seams. you can do, both by hand and by machine. It is made of a straight line of lines of equivalent length. Also utilized in embroidery as a laying out and filling stitch. Hand seams, for example, tucks, gathering, shirring, quilting and mending should be possible with these stitches. Running stitch very delicate sewing such as fine seaming and tucking. It is similar like even basting, but these stitches are very small. The fastens should be straight, fine and uniformly separated and around 1/16 to 1/8-inch-long. Pass the needle through the fabric a few times before pulling it through the fabric.

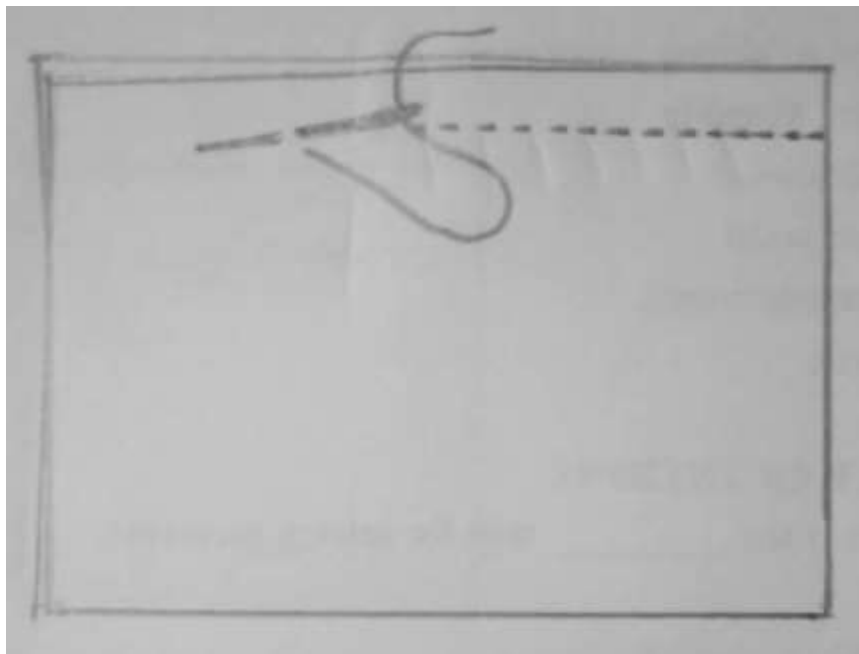

Running stitch (fig-6)

4.4.2 Hemming

This is utilized to verify down a folded edge of material like hems. Hemming must be as invisible as conceivable on the correct side. Hemming shows up as little slanting stitch on the wrong side and right side. Begin the

hem with a little knot and complete with the equivalent the stitches should be fine and divided close enough to hold the sew safely in place, yet far enough separated to be subtle from the correct side of the garment. Before beginning the hem, affix the thread with a few little stitches over one another. Complete off the sewing also with a few joins to fasten it safely. There are two kinds of hems – slip trimming and knot sewing. Hemming stitch generally used in all garments. This stitch generally used for finishing sleeve edges, handkerchief, skirt, hemline, neckline edges, piping, pillow covers and other edges also.

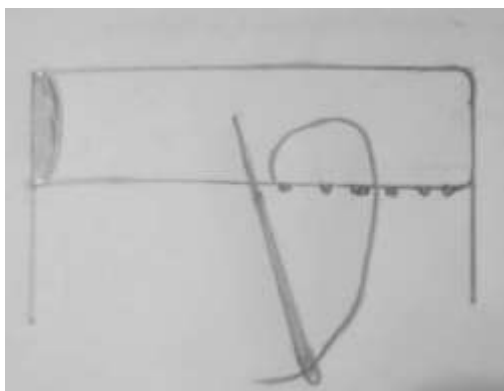

Hemming (fig-7)

4.4.2.1 Slip stitching / Blind Hemming:

This is utilized for trims, facings or folds where invisibility could easily compare to quality. Secure the thread underneath the trim, bringing the needle out through the edge of the fold. Take a modest line in the garment straightforwardly underneath the point where the thread leaves the fold. Initially insert the needle in the sew, bring out the needle and take one or two thread from the main part. slip it along inside the overlay and bring it out again about ½ inch away. Repeat the steps again. And complete the blind hemming.

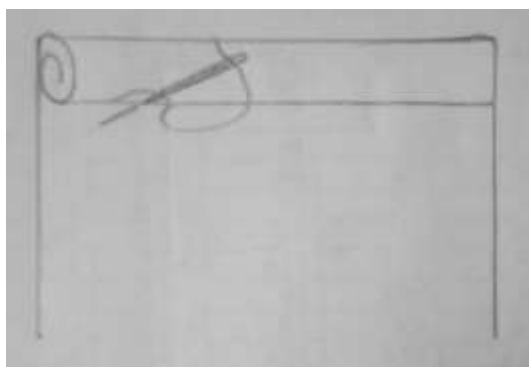

Blind hemming/slip stitching (fig-8)

4.4.2.2 Knot hemming

This is worked from appropriate to left. A little vertical hemstitch is made to such an extent that the thread goes around the tip of the

needle that on pulling the needle out forms a knot around the stitch made. In this manner, each stitch is fixed safely by methods for a knot and in this manner is very solid.

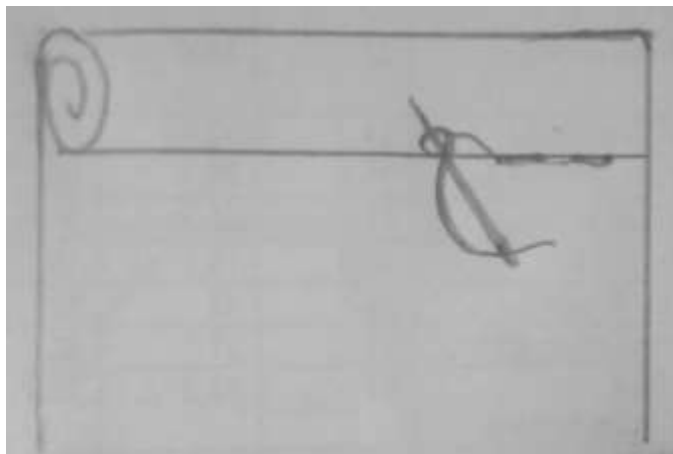

Knot hemming (fig-9)

4.4.3 Back stitch

Back stitch is used as a decorative stitch. This makes very strong stitch. The back stitch is solid and now and then substituted for machine stitch. It requires some time. Care must be taken while sewing, on an inappropriate side of the texture the join is like stem line. Stitch ought to be around 1/8" long on the correct side. To make the back stitch, drive needle up through the material at a point on the sewing line around 1/8" from its correct end. Take a stitch embedding the needle 1/8" back of the thread toward the start of the sewing line and getting it out an equivalent separation the front of the thread. Again, start this process.

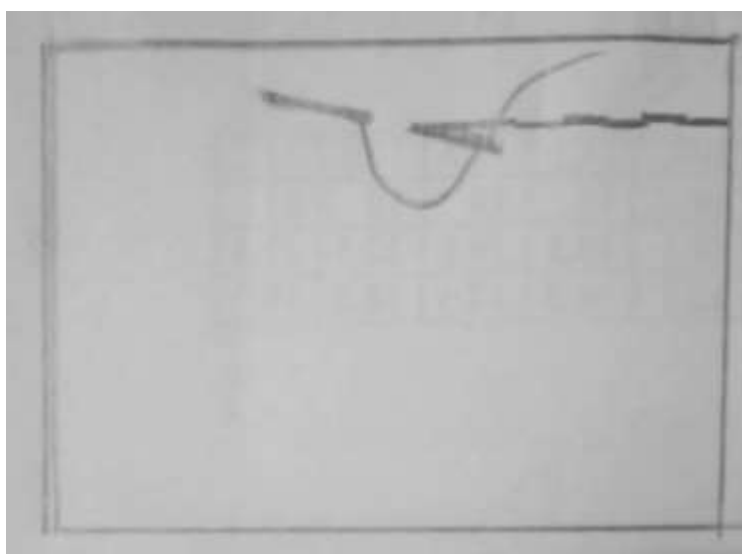

Back stitch (fig-10)

4.4.4 Run and back or combination stitch

This stitch is similar like back stitch. In this a backstitch and three or four running stitches are consolidated and can be utilized for working plain seams done by hand. This stitch is quicker than the backstitch and more secure than the running stitch.

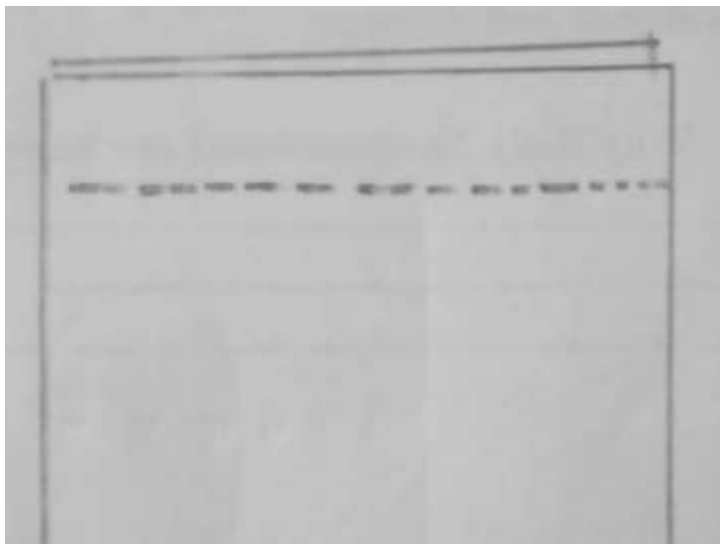

Run and back or combination stitch (fig-11)

4.4.5 Overcast stitch

This stitch is utilized to verify two completed or folded edges together, or for applying ribbon or patch or addition. Fold and press back the two seam stipends to wrong side and place the texture right sides looking with the seam lines matching. Addition the needle through the back overlap and after that through the front fold, picking up only one or two threads each time. Bring the needle out diagonally to the left. This delivers a straight stitch. The stitches should be kept near one another. This is like whip stitch and is normally utilized on the crude edge of the texture.

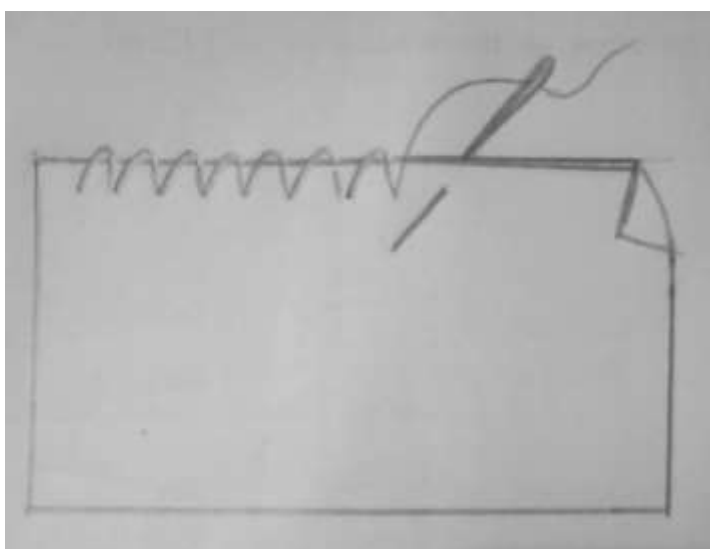

Overcast stitch (fig-12)

4.3.6 Whipping

This stitch is like overhand stitch and fills a similar need. In some cases, it is utilized to complete edges of handkerchiefs, the main distinction between over giving and whipping is that the later creates inclining lines, taking stitches over the edge with the needle in a straight position.

This stitch is utilized to complete raw edges of textures and furthermore in sleeves, and collar of child's wear. The other name for this stitch is over casing and rolled fix. Whipping produces slanting stitches taking stitches over the rolled texture edge with needle in a straight position.

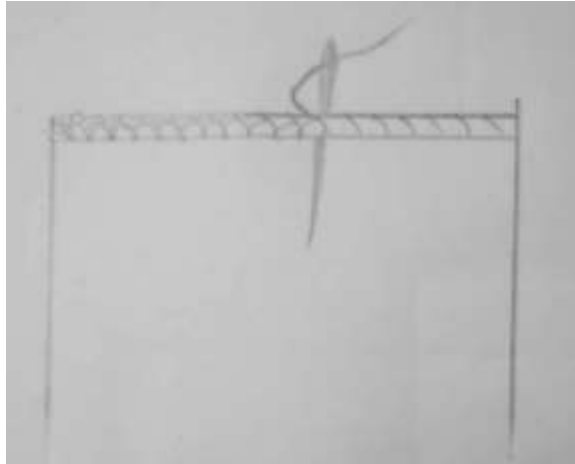

Whipping (fig-13)

Check Your Progress II

6. What is permanent stitch?

7. Describe about hemming stitches.

8. What are overcast stitches?

Multiple Choice Questions

1 Which stitch is similar like back stitch?

(A) Even basting

(B) Whipping stitch

(C) Permanent stitch

(D) Run and back or combination stitch

2 Which stitch is similar both side of fabric

(A) Even basting

(B) Hemming

(C) Blind stitch

(D) Pin basting

3. Hemming stitch generally used in_____.

(A) neckline

(B) Hem line

(C) Skirts

(D) All above

4. Which stitch is stronger stitch?

(A) Uneven basting

(B) Back stitch

(C) Pin basting

(D) None

5. Which kind of stitches are short length stitches

(A) Permanent stitch

(B) Temporary stitch

(C) Running stitch

(D) (A) and (B) both

4.5 Let Us Sum Up

Hand sewing methods will help in garment development with or without utilization of sewing machine. Both temporary and permanent stitches are valuable. Particularly impermanent stitches are progressively helpful to the beginner's in garment development as they fill in as controlling lines to permanent hand or machine stitches.

4.6 Key Words

Empower- make stronger and more confident

Named-termed, called

Underneath- below, under

Appear-look, seem

Conceivable- possible, imaginable

Appeared- looked, seemed

Inappropriate-unsuitable, wrong

Embeddings-inserting, fix, implanting

4.7 Suggested Books

<https://www.textileschool.com/304/hand-stitch-types/>

<https://sewguide.com/easy-hand-stitches/>

Reader's Digest "Complete Guide to Sewing"

Answers

Check Your Progress I

1. preparation is required before doing hand stitches

- Using strong thread for hand stitches.
- Use a same colour thread to the garments for hand stitches
- Hand needles arrive in an assortment of sizes and types. For better fabrics, utilize a little needle.
- Use a better needle when short, single stitches are required. Longer needles are preferred when various stitches are to be sewed at once, for example, basting.
- using thread no longer than 18 to 24 inches. it is always important to select the appropriate thread and needle for the fabric and garments.

2. **These temporary stitches** are named as attaching or basting stitches. They help in holding at least two layers of material together before the permanent stitches are made. Normally these stitches are worked in horizontal and from right to left. This is the main stitch which is starts with a knot. For attaching it is smarter to utilize a difference shading threads. The length of stitches will be depending upon the heaviness of the fabric and how safely the pieces must be held together. There are a few kinds of attaching or basting stitches.

3. Temporary stitches

- Even basting
- Uneven basting
- Diagonal basting
- Slip basting

- Pin basting

4. **Even basting**

This is utilized for attaching seams and additional detail. It is a short temporary stitch utilized on smooth texture and in places that require close control, for example, curved seam. The stitches are of equivalent length about $\frac{1}{4}$ inch on the two sides of the material.

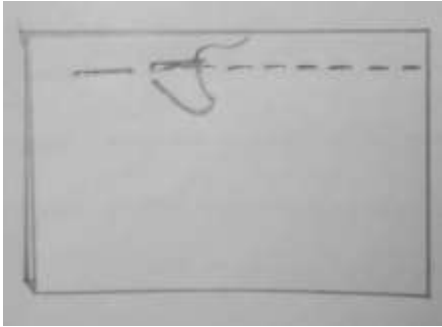

Even basting

Uneven basting

In this stitch on the upper side is $\frac{1}{2}$ " or possibly twice that on the underside ($\frac{1}{4}$ "). This stitch can be utilized for longer overlays and seams. This is relatively more grounded than even attaching. Utilize this kind of attaching as guideline or where there is short or no strain.

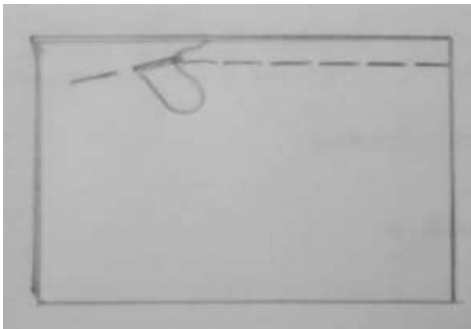

Uneven basting

5. **Slip basting** is additionally used to bast seam lines that have been fitted from the correct side of the garment. Overlap one seam edge under and stick it over the other seam edge along the sewing line. The single layer and come up again $\frac{1}{4}$ to $\frac{1}{2}$ inch away through the three layers as before. Proceed till the end. Stitch on wrong side will be slightly diagonal. Little stitches will show up on the correct side.



Check Your Progress II

6. **Permanent stitches** are left in the piece of clothing and form a piece of the sewed garment is permanent stitches. Knot is not commonly utilized for beginning the permanent stitches. A few stitches toward the start of a line will be useful in verifying the lines. These stitches are made permanent on the fabrics and need not be removed later like Temporary stitch. Some of permanent stitches are 1. Running stitch 2. Back stitch 3. Run and back stitch 4. Hemming stitch 5. Whipping stitch 6. Over sewing.

7. Hemming

This is utilized to verify down a folded edge of material like hems. hemming must be as invisible as conceivable on the correct side hemming shows up as little slanting stitch on the wrong side and right side. Begin the hem with a little knot and complete with the equivalent the stitches should be fine and divided close enough to hold the sew safely in place, yet far enough separated to be subtle from the correct side of the garment. Before beginning the hem, affix the thread with a few little stitches over one another. Complete off the sewing also with a few joins to fasten it safely. There are two kinds of hems – slip trimming and knot sewing. Hemming stitch generally used in all garments. Hemmed stitch garments might be show problem as:

- knot noticeably appeared on right side
- Puckered sew
- Attached thread appeared on right side
- stitches not evenly separated

This stitch generally used for finishing sleeve edges, handkerchief, skirt, hemline, neckline edges, piping, pillow covers and other edges also.

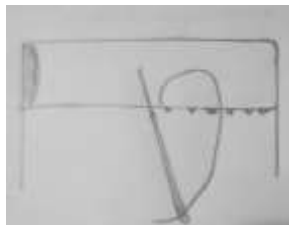

Hemming

1 Slip stitching / Blind Hemming:

This is utilized for trims, facings or folds where invisibility could easily compare to quality. Secure the thread underneath the trim, bringing the needle out through the edge of the fold. Take a modest line in the garment straightforwardly underneath the point where the

thread leaves the fold. Presently insert the needle in the sew, bring out the needle and take one or two thread from the main part. slip it along inside the overlay and bring it out again about ½ inch away. Repeat the steps again. And complete the blind hemming.

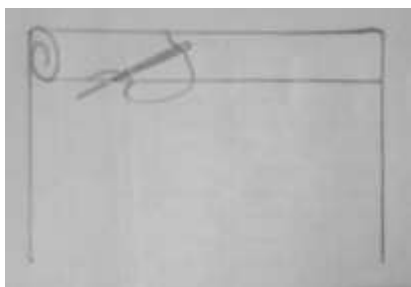

Slip stitch/Blind hemming

2 Knot hemming

This is worked from appropriate to left. A little vertical hemstitch is made to such an extent that the thread goes around the tip of the needle that on pulling the needle out forms a knot around the stitch made. In this manner, each stitch is fixed safely by methods for a knot and in this manner is very solid.

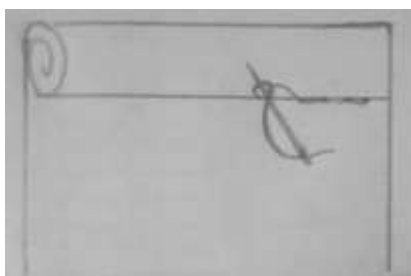

Knot hemming

8. **Overcast stitch** is utilized to verify two completed or folded edges together, or for applying ribbon or patch or addition. Fold and press back the two seam stipends to wrong side and place the texture right sides looking with the seam lines matching. Addition the needle through the back overlap and after that through the front fold, picking up only one or two threads each time. Bring the needle out diagonally to the left. This delivers a straight stitch. The stitches should be kept near one another. This is like whip stitch and is normally utilized on the crude edge of the texture.

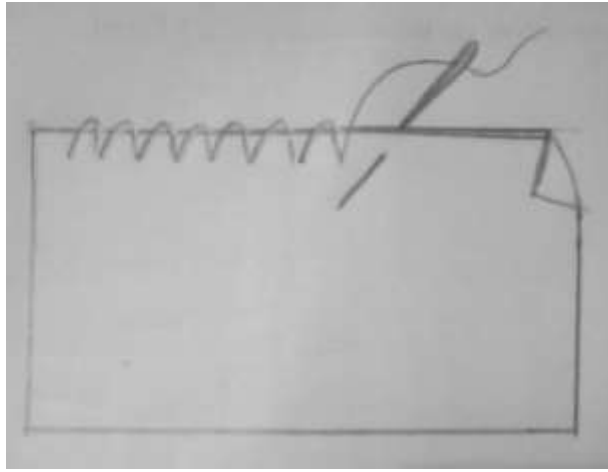

Overcast stitch

Multiple Choice Questions

1(D) 2(A) 3(D) 4(B) 5(C)

Unit 5 Preparing Fabric before Sewing

5.0 Objectives

5.1 Introduction

5.2 Importance of Grain Line

5.3 Shrinkage

5.3.1 Cotton and Linen

5.3.2 Silk, Rayon and Wool

5.3.3 Closely Woven Starched Cotton

5.4 Marking and Cutting Fabric

5.4.1 Transferring Pattern Marking

5.4.2 Cutting Fabric

5.5 Straightening of Fabric

5.6 Pattern Layout

Check Your Progress

Multiple Choice Questions

5.7 Let Us Sum Up

5.8 Key Words

5.9 Suggested Books

Answers

5.0 Objectives

- To understand the students for preparation of fabric before sewing
- Understand the student carried out steps for drafting and pattern making before sewing,
- Enable the students about grain line shrinkages and direction of print to be consider before sewing.

5.1 Introduction

Fabric of any type must be pre treated before cutting to avoid later alterations or Damage in the finished garment. The untreated fabric may be of correct size on the first Wear, but due to repeated washing it may shrink and be uncomfortable to the wearer. Grain perfection is another factor which may deform the silhouette of the garment. These factors must be given due considerations before cutting.

5.2 Importance of Grain Line

Grain alludes to the direction of yarns in texture. Woven textures are comprised of the lengthwise and crosswise yarns interweaved at right angles to one another. The lengthwise or twist yarns are typically heavier or solid and exceptionally bent yarns. The lengthwise direction of the fabric should hang straight down on the figure from the neck to the waist, from the armhole to the elbow, from the waistline to the base of the shirt. Grain is significant in the little places just as the primary bits of a piece of clothing. It is useful to have a crosswise grain line drawn on such example pieces as sleeves, yokes and collars.

In well-developed clothing, not exclusively should the longwise grain run the lengthwise on the body yet the crosswise grains ought to be at right angles to the lengthwise grain or parallel to the floor at the base of the neck, over the bust, over the fullest part of the hip, at the base of the sleeve and so on. This can't be accomplished if you are utilizing an off-grain texture for cutting. The result will be a bad fitting of clothing which will wrinkle, lacks balance and is awkward to wear. If a dress design should look adjusted on the figure, the correct half and left half ought to be identical in design, shape and grain.

5.3 Shrinkage

All textures have propensity to shrivel when plunged into water unless if they are pre-contracted. Excessive shrinkage can demolish the attack of the clothing. While sewing, if the fabric has not been pre-shrunk additional recompense for shrinkage ought to be kept. For different kinds of textures diverse shrinkage treatment must be given.

5.3.1 Cotton and Linen

If the texture is white cotton it ought to be considered at any rate 4 hours in hot water to expel starch. To shrivel the material consistently the situation of the fabric in vessel ought to be changed occasionally. For hued materials Luke warm water ought to be utilized and similar procedures pursued with respect to white textures given previously. Distinctive shaded textures ought not to be inundated in water together. Each shading ought to be inundated independently. After the material has been shrunk it ought to be permitted to dry in conceal and ought not to be pressed to remove water. The solid materials like canvas or long fabric and so on ought to likewise be shrunk before they are utilized.

5.3.2 Silk, Rayon and Wool

As silk and rayon shrunk very slowly, it is not important to pre-shrunk them before cutting. Little remittance might be kept while sewing the clothing. Woollen materials can be shrunken in two different ways.

1. One method is to steam the materials as pursues. The material to be dealt with ought to be spread over a table and folded right side facing. Presently place a damp towel between the two layers. Spread an ordinary cloth on the upper side of the fabric; at that presses it with moderately hot iron. This will give the essential steaming. This procedure ought to be repeated everywhere throughout the texture.

2. The second strategy is laying a layer of wet muslin or long material over the texture and rolling the two together and following it to stay in this situation overnight. After this the muslin or long material should be removed and the woollen texture is spread on the table with wrong side facing up. The texture should now be squeezed and permitted to dry normally.

5.3.3 Closely woven starched cotton

Dip the texture into mild soap solution for at any rate for four hours. For uniform shrinkage the situation of the fabric ought to be changed at times. It should then be removed and washed with cold water 3 to 4 multiple times, and afterward permitted to dry without pressing. The fabric ought to be squeezed, before it is totally dry.

5.4 Marking and Cutting Fabric

It is necessary to mark all details from the pattern to the cloth, which will be needed during the construction of the garment. Mark these details:

1. Seam lines.
2. Centre front and centre back lines.
3. Darts
4. Fold lines
5. Positions for pleats or gathers or Pockets
6. Buttonholes and buttons
7. Any other special markings used to construct the garment

5.4.1 Transferring Pattern Marking

The fastest and most accurate way to move development details from pattern to material is with dressmaker's tracing paper or carbon utilize a tracing wheel and the carbon mounted on a heavy cardboard to secure table surfaces. Subtleties ought to be set apart on a wrong side of the material where most development lines are required. Utilize white tracing paper any place conceivable because it is safe. If carefully handled its mark last longer. The pigment in coloured tracing paper leaves a more permanent line. It can usually be removed by scrubbing; but conventional washing

strategies and dry cleaning don't generally remove it. So first Test a piece of your garments before denoting the article of clothing segments ought to have been cut with the correct sides of the material together, or when cut from a single thickness, with the correct side up, beside the pattern.

Certain lines, for example, those for folds and a few kinds of pockets and buttonholes are required on the correct side of the material. Make the longest machine stitch called a baste line alongside the followed lines on the underside of the material. stitch through a single layer. The basting shows the detail on the correct side of the fabric.

5.4.2 Cutting Fabric

Keep the closures and sides of the material parallel with table edges consistently so the grain never moves. Stroll around the table for cutting, rather than pulling the material. Moving the pattern and material will move the grain and result in uneven cutting. Try not to get the fabric from the table or slip the left hand between the material and the table. Hold the left hand down on the pattern near the front line and cut with long even strokes with right hand. Keep the cutting sharp edge or shears resting on the table. Have the thumb in the round handle and the fingers in the long handle, so that shears won't cut at an angle. Cut with long, smooth strokes with the full length of the shears. Cut precisely even with the cutting ages as showed on the pattern. Cut notches outward. A few indents might be cut as one wide notch. Investigate the guide sheet or pattern to find out whether additional pieces will be required in completing, for example, shaped facings, bias binding, straight bands for cuffs or strips for piped buttonholes.

5.5 Straightening of Fabric

A. First technique: Many times, fabric should be straightened before the garment is cut out. Draw out a crosswise string and cut cloth along the string if the cloth has not been tom from the roll. At that point the clothing will fit better and hold its shape longer. To see whether it is straight, place it on a huge table and make a lengthwise overlap down the inside to meet both selvedge together smooth out wrinkles. If the two selvedges meet equitably with the side of the table and the raw edges meet up even with the parts of the table, then the fabric is straight. If the two edges don't meet up and are not even with the finish of the table, the material isn't straight.

B. Second technique: The second method is by pulling the texture on the bias. At the point when texture is pulled on the bias, it stretches. Continuously pull the edge of the shortest edge moving the hand over a few inches each time. The fabric is given a decent, firm pull. Now and again an accomplice is important to help fixing the material. At that point, everyone should pull with a correct hand and again with the left hand. Keep pulling first with one hand and then the other until the material is straight. Repeat this until the selvedge of the material meet up. After this, press the

material if the fabric is wrinkled. dampen it with a damp material, press along the long way of the texture however not in the circle. Utilize a seat to hold the material with the goal that it doesn't fall on the floor.

5.6 Pattern layout

The placement of pattern on the fabric in an economical way, that is without wasting fabric. It's called pattern layout.

Principles of Pattern Layout: Some of the principles to be considered while laying patterns are:

1. Press the texture just as the pattern pieces level before laying the pattern on the texture.
2. Utilize an enormous table or any hard level surface for obliging the work.
3. If an open layout is utilized, place the texture straight up on the table. For every single other layout overlaps the texture right sides confronting and wrong sides out.
4. Decide the most ideal approach to overlay your fabric and this will depend upon the width of the material, width of your pattern pieces, the kind of material and structure of the clothing. (Regardless of whether left and right are indistinguishable. Regardless of whether numerous pieces must be cut on crease the clothing (whether left and right parts are indistinguishable, whether numerous pieces must be cut on overlay and so forth.) The basic strategies for collapsing the fabric for spreading out example pieces are the following.

A. The lengthwise centre fold: Here the texture is folded down the centre parallel to the selvedge with the goal that the selvedge meets up. This is the most as often as possible utilized fold. The layout for a simple frock on this kind of fold is illustrated in the figure.

B. Off centre lengthwise fold: This is utilized when limited pieces must be cut on fold. To guarantee that the fold is parallel to the selvedge, mark focuses estimating the necessary separation (width of the half pattern including seam allowance) from the selvedge at ordinary interims and fold along the markings. The layout for a kid's panty on this kind of layout is illustrated in the figure.

C. cross wise centre fold: This is suitable for materials that are too narrow to accommodate the width of pattern pieces when folded the lengthwise.

D. Off centre cross wise fold: When just a piece of the material is required to cut pattern pieces that are too wide for the length wise fold layout, this type of fold is utilized.

E. Combination fold: Here lengths wise fold and cross wise fold are combined.

F. Open layout: In this kind of layout, the texture is not folded at all. This is utilized particularly for designs which recapture both ways parts to be cut independently.

Make a preliminary format by keeping loads or two pins for every example, to ensure that fabric will be adequate. Rules 6 to 9 must be borne as a main priority while making the preliminary design.

5. Straight grain lines on designs must be held parallel to the texture selvedge. To guarantee this, quantify and alter the example with the goal that the two parts of the bargains grain line are a similar good ways from the selvedge and pin the example to the texture along the grain line arrows.

6. Overlap lines on the patterns must be kept on collapsed edges of texture.

7. Leave enough space between designs for cutting outward notches and marking seam allowance (if the examples do exclude seam allowances). Likewise ensure that there is sufficient material forgotten about for cutting belts, facings, and so forth for which you might not have made paper designs.

8. The patterns must be set on the texture in the most efficient manner.

9. Pin examples to the texture immovably, after situation of the pattern has been chosen, pin the corners and the long outside edges of the patterns, setting pins near and roughly opposite to the cutting line. Utilize simply enough pins to keep the example in position. An excessive number of pins will misshape the edges. You should begin cutting the texture simply in the wake of sticking all the pattern pieces.

10. Take care to utilize exceptional formats for deviated designs and for textures with strong structures, striped and checked designs, designs going in one bearing and textures with nap and pile.

Check Your Progress

1 Which point should be kept in mind before fabric sewing?

2 Write about importance of checking shrinkage before fabric sewing.

3 Give the information about first technique of straightening fabric.

Multiple choice questions

- 1) The lengthwise or twist yarns are typically _____.
- A) Solid and heavier
 - B) Smooth
 - C) A and B
 - D) None of above
- 2) Lengthwise and crosswise fold is performed in
- A) Crosswise centre fold
 - B) Off centre crosswise fold
 - C) Lengthwise centre fold
 - D) Combination folds
- 3) Which fabrics shrunk very slowly? As silk and rayon shrunk very slowly
- A) Cotton
 - B) Silk and rayon
 - C) Jute
 - D) All of above

5.7 Let us sum up

There are many steps before sewing any kind of garment. Those steps such as define grain line of fabric direction of prints, types of fabrics, and its shrinkage. Another step is preparing lay-out according to measurement of the garment and makes it by drafting and pattern layout. After this all process fabric is ready for cutting. And then Cut the fabric is done by straight and soft curvature line and then those all parts of cut fabric are ready for sewing.

5.8 Key words

Dodge- avoid

Shrivel- shrink

Alludes-refers

Soggy-damp

Obliging- making, requiring

5.9 Suggested Books

<https://mellysews.com>

<https://www.brainkart.com>

<https://shop.myblueprint.com>

Answers

Check your progress

1. Points should be kept in mind before sewing fabric are given below,

- Importance of grain line
- Shrinkage
 1. Cotton and Linen
 2. Silk, Rayon and Wool
 3. Closely woven starched cotton
- Marking and cutting fabric
 - 1 Transferring Pattern Marking
 - 2 Cutting Fabrics
- Straightening of Fabric
- Pattern layout

2. Shrinkage is one of the most important part which should affect of cutting and sewing process. while sewing, if the fabric has not been pre-shrunk additional recompense for shrinkage ought to be kept. For different kinds of textures diverse shrinkage treatment must be given. All textures have propensity to shrivel when plunged into water unless if they are pre-contracted. Excessive shrinkage can demolish the attack of the clothing.

3. Here is basic information about the first technique of straitening fabric.

Many times, texture should be fixed before the garment is removed. Cut out across wise string and cut texture along the string if the texture has not been torn from the roll. At that point the clothing will fit better and hold its shape longer. To see whether it is straight, place it on a huge table and make lengthwise overlap down the inside to meet both selvedge together smooth out wrinkles. If the two selvedge's meet equitably with the side of the table and the raw edges meet up even with the parts of the table, then the fabric is straight. If the two edges don't meet up and are not even with the finish of the table, the material isn't straight.

Multiple Choice Questions

1) A 2) D 3) B

UNIT: 6 BASIC SEAMS

- 6.0 Objectives
- 6.1 Introduction
- 6.2 Importance of Seams
- 6.3 Types of Basic Seams
 - 6.3.1 Plain Seam
 - 6.3.2 Lapped Seam
 - 6.3.3 French Seam
 - 6.3.4 Flat Felled Seam
 - 6.3.5 Welt Seam
 - 6.3.6 Piped Seam
- 6.4 Check Your Progress
- 6.5 Multiple Choice Questions
- 6.6 Let Us Sum Up
- 6.7 Key Words
- 6.8 Suggested Books
- Answers

6.0 Objectives

- In this unit, you will learn regarding types of basic seams.
- To Gain knowledge regarding usefulness and practicability of seams
- To impart knowledge about seams with its variation in garment.

6.1 Introduction

Seams are very important part in garment making. We can joint two or more pieces of cloth by using seams. Generally some seams like a side seam, underarm seam, waist line seam etc. which are flat. And this kind of seams used mostly in undergarment. Some seams like a piped seams, corded seams, flat seams etc. There are so many types of seams. Seams inside garments are used in collar and cuffs and structural seams are used to join the main section of garment. To prevent raveling of raw fabric edges seams are finish with a variety of techniques.

While stitching garment there are three type of basic stitches, **1) straight stitch 2) curved stitch and 3) corner stitch**

- 1) **Straight stitch:** generally straight stitch used in garment making. Straight stitch is used in length wise stitching, Width wise stitching and bias line stitching in garment. Generally, Seam allowance is kept in stitching process which is depend on the type of fabric and type of seam. Straight stitch used for seam finishes too.
- 2) **Curved stitch:** curve stitch is used generally in garment for armhole neck line etc. While stitching curve stitch we should be very careful. For making perfect stitch line. In this kind of stitch the speed of machine should be slow, keep the length of stitch small, and to corner line should also a lining with curve stitch.
- 3) **Corner stitch:** Generally this kind of stitches is used for v neck line, belt, and pockets at the corner of collar. In this stitch when corner part come, we should jab the needle in fabric and then pulled up the pressure foot then turn the fabric ahead and continue the stitching.
 - **Classes of seams:** seams classified in four parts according to federal standard no. 751. Each part identifies with English letter and according to the part of seam they become different types of seams.
 - LS: Lapped seam
 - SS: Superimposed seam(simple seam)
 - FS: Flat seam
 - BS: Bound seam
 - **Seams depends on some points mention below:**
 - Fabric type
 - Position and placement of seam
 - Care of garment
 - Use of garment

6.2 Importance of Seams

- **Significance and use of seam:** Selection of correct seam type for assembly is very important as the improper selection of stitch type, seam type or thread type can result in failure of the sewn seam and failure of the garment. The most important aspect of a properly constructed sewn seam is strength, elasticity, durability, security, and appearance. These characteristics must be balanced with the properties of the material to be joined to form the optimum sewn seam. The selection of the seam type and stitch type should be based upon these considerations.
 - Methods of Garment Fusing
 - Textile Design in Apparel Making
 - Clothing and Design in Garment Making
 - Support Operations for Garment Manufacturing

- **Strength:** The seam efficiency of the sewn seam should be so that sewn seam strength is balanced and can withstand the everyday usage of the garment.
- **Elasticity:** Elasticity of sewn seam should be slightly greater than that of the material which it joins. This will enable the material to support its shape of the forces encountered for the intended end use of the sewn item. The elements affecting the elasticity and strength of a sewn seam depends upon fabric type and strength, seam type, stitch type, stitch density (SPI), thread tension, and thread strength and elasticity.
- **Durability:** Durability of a sewn seam depends largely upon its strength relative to the elasticity of the seam and the elasticity of the material. For making a durable sewn seam, the thread size and stitch density must be carefully chosen to avoid puckering.
- **Security:** Security of sewn seam depends chiefly upon the stitch type, SPI, and its susceptibility to become unraveled. The stitch must be well set to the material to prevent snagging that can cause rupture of the thread and unraveling of certain stitch types.
- **Appearance:** Appearance of a sewn seam generally is governed by the proper relationship between the size and type of thread, the stitch density, and the texture and weight of the fabric.

6.3 Types of Seams:

6.3.1 **Plain seam:** This seam mostly used in garment, because this is easiest seam to make. We can make it by Hand or machine. In this seam two edges are joint together entire length of seam. It is also known as single needle butterfly stitch. Generally plain seam is used for the finished fabric and also joint lining with garment.

There are three types of plain seam: 1) **Straight seam** 2) **Curve seam** 3) **Corner seam**

1) **Straight seam:**

In this seam straight stitches are used the purpose of straight seam is joint to fabric edge. Mostly plain straight stitch is used for joint.

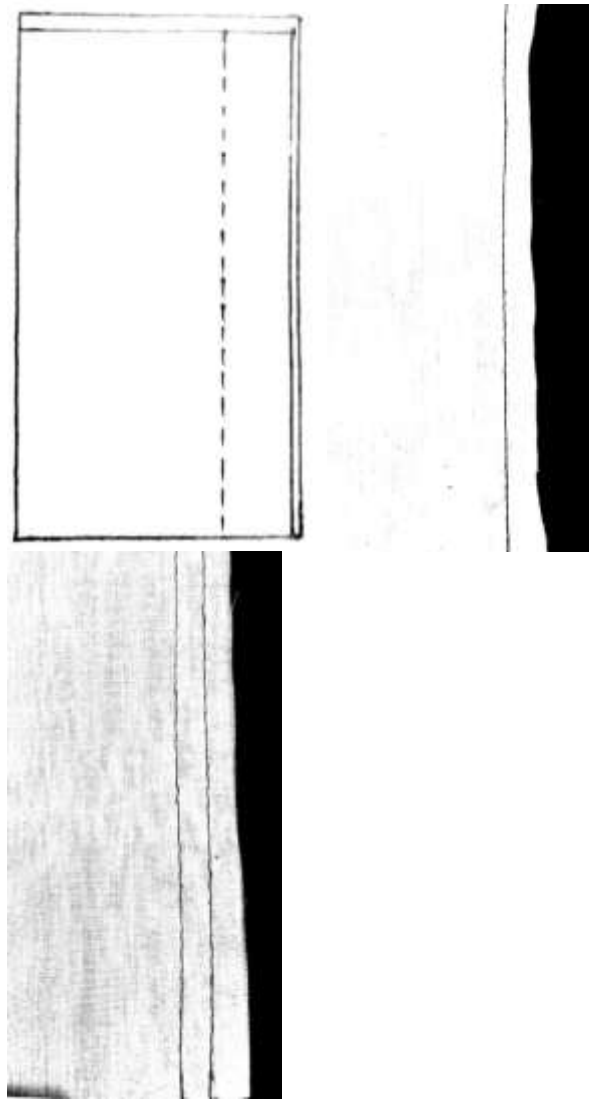

Simple plain seam (fig-1)- similar line plain seam (fig-2)

2) Curve seam:

This seam is used for curvature shape in garment like armhole neckline etc. Curve seam requires careful guiding for same even distance from the edge. To use of shorter stitch length and slower machine speed. We can get better curve seam.

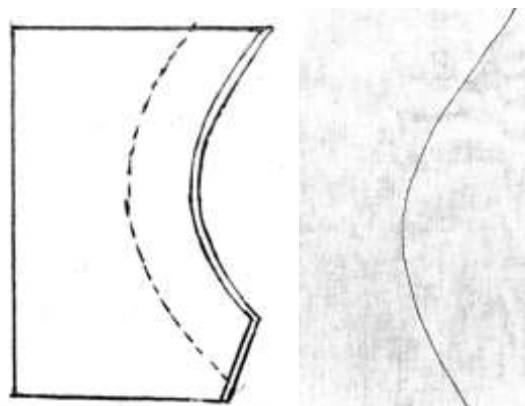

Curve seam (fig-3)

3) Corner seam:

Corner seam made with small stitches. Generally corner seam used in collar, v neckline etc, in this seam corner should be blunted for better point result.

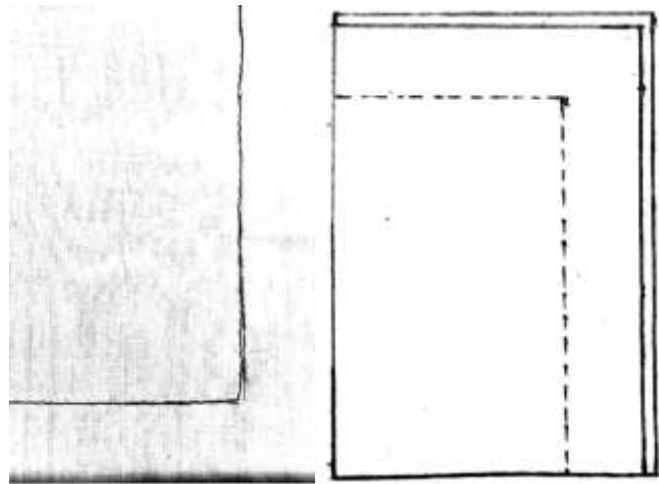

Corner seam (fig-4)

How to sew corner seam:

First take two pieces of fabric and put the one piece upon the second

Piece of the fabric, then stitch on the both side of the seam at equal distance.

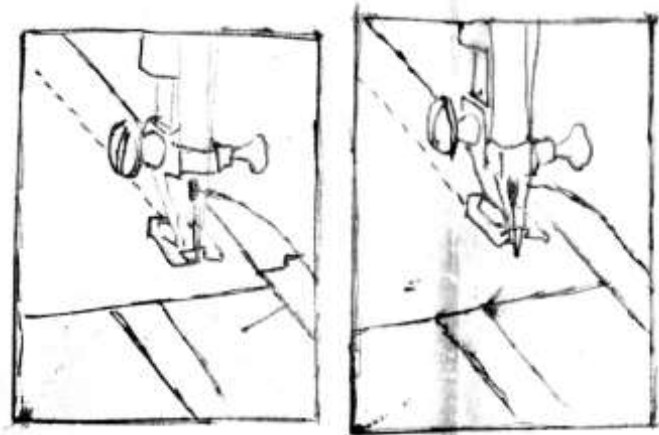

Step 1 (fig-5)

step 2 (fig-6)

Step 1: stitch line up edge of fabric

Step 2: stopping needle in fabric and raise presser foot.

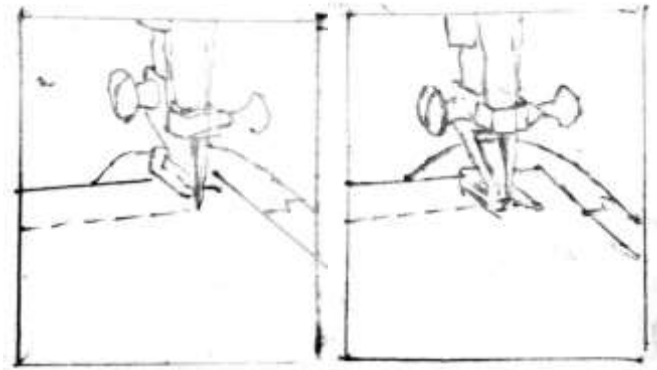

step 3 (fig-7)

step 4 (fig-8)

Step 3: stitch in the new direction

Step 4: keeping edge of fabric even with the 5/8" guideline

➤ **To join an inward corner:** For this seam with an outward corner or straight edge first reinforce inward angle and stitch 1 inch inside seam line either side of corner. Then insert diagonally across to the point where stitching forms the angle. Clip exact to the point and do it carefully not to cut past this stitch. Spread the clipped part to fit the other edge, pin in position then stitch on the seam line pivoting at the corner with side up clip.

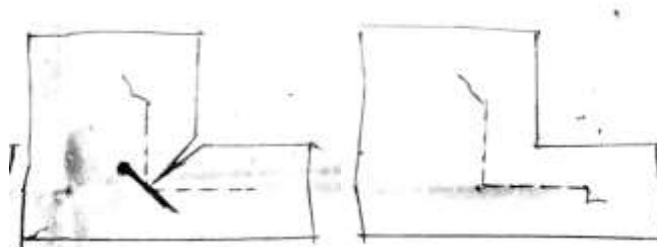

To join an inward corner (fig-9)

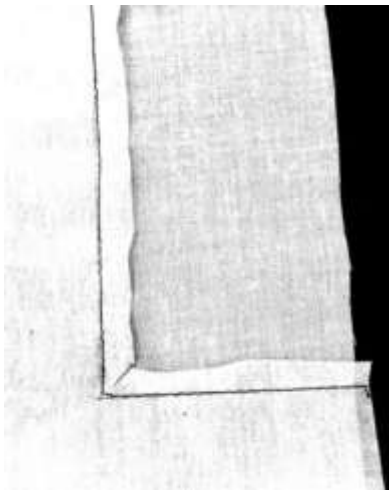

(Fig-10)

- **Supporting seam technique:** sometimes additional seam technique involves in seam 1) trimming 2) grading 3)to trim a corner4)notching & clipping

1) Trimming:

Trimming means cutting away some of the seam allowance the purpose of trimming is to get good fitting and decrease fabric part. Example: armhole, And further construction.



Trimming (fig-11)

2) Grading:

Grading is used with the seam allowance that will fall the nearest garment side cut the widest grading is use when the edges are enclosed. It is helping to seam keep straight without making thick or bulky layer.

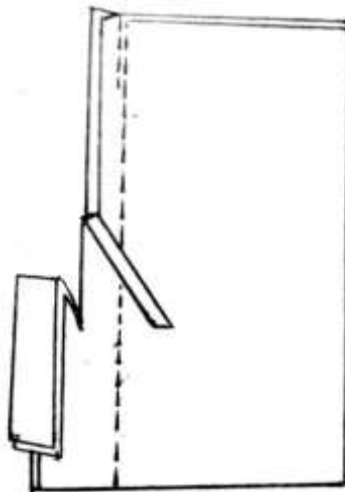

Grading (fig-12)

3) To trim corner:

To enclose seam end, control the layer to trim corner is used. First trim the Seam allowance across to the point close to the stitching then cut the other side. There is no danger of seam allow a cover laping because of to trim corner.

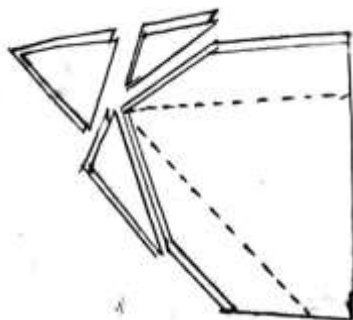

To trim corner (fig-13)

4) Notching & clipping:

Notches are help to cut from seam allowance of concave, curves open by removal fabric. And it is use for also cut into the seam allowance of convex, curves.

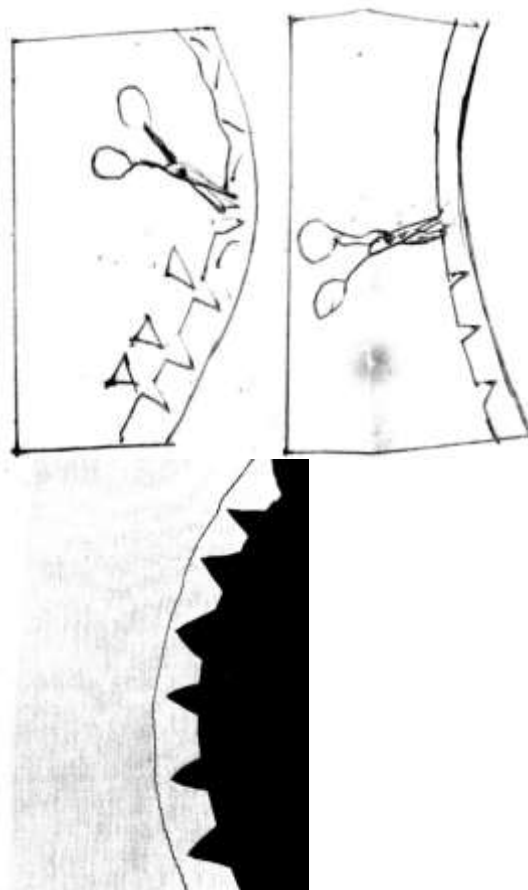

Notching (fig-14)



Clipping (fig-15)

6.3.2 Lapped seam: Lapped seam also known as tuck seam when the lap seam is wide and giving the effect of tuck. This seam is use for lap one edge of fabric for the other with seam lines which is meeting in the center. Yoke gazette are join with help of this seam. By this seam line may showed in front part of garment. This seam is used to eliminate bulk, especially on interfacing and interlining.

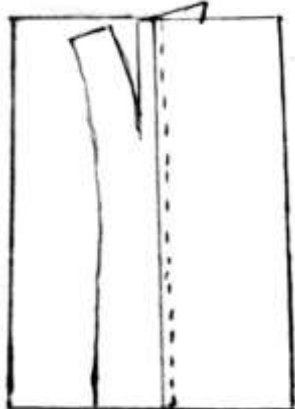

Lapped seam (fig-16)

How to sew lapped seam: First take two piece of fabric and decide which piece will be on the top with this seam. To begin overlap your fabric the width of your seam. And then Stitch down the middle of the overlap and stitched straight down the middle. And turn back side then if required, trim your seam. Close edges and press it.

6.3.3 French seam: French seam is a method for double seam which is used to hide the rough edges of the fabric. It is often use for clothing and children wear, ladies garment, and under garment. French seam is generally use for shiny and thin fabrics like chiffon, organza georgette etc, With help of this seam, We can get inner side clean finish in garment.

How to sew French seam: For making French seam, first on the right side of the fabric mark stitching line with $\frac{1}{2}$ inch seam allowance, then on the wrong side mark line halfway

through the original seam allowance for half inch, mark stitching line at ¼ inch. Then stitch the plain seam at this ¼ inch line trim seam allowance. Then fold the fabric over at the seam right side together covering edges and press it. Stitch at the ½ mark right side of the fabric. Press flat and then to one side.

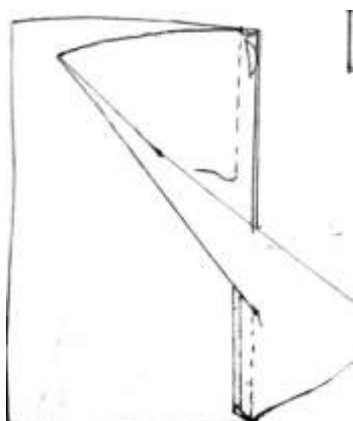

French seam (fig-17)

6.3.4 Flat felled seam: this type of seams is mostly used on men's sports shirts, work clothes and children's clothe and bottom garments. This seam generally used in reversible garment and formal wear garments. In industry felling foot is used for operating this seam in one line. Flat felled seam is very sturdy.

How to sew flat felled seam: First take two pieces of fabric and pin them together opposite side facing and sew the seam with opposite side facing. Then press the seam open on both side of the fabric. Now trim one side of seam allowance down to ¼ inch. Then press the untrimmed seam allowance and top of the trimmed side. Now fold the pressed side under tucking the raw edge into the fold. Line up the fabric in machine, and stitch along the edge of the fold, trapping all the raw edges inside.

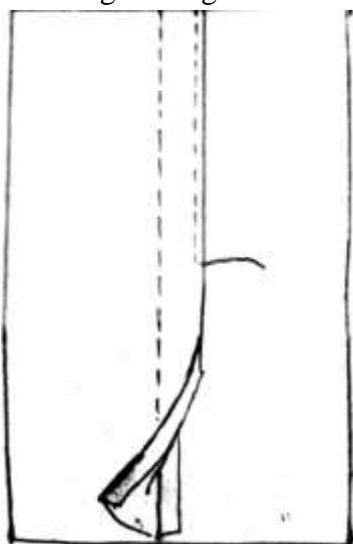

Flat felled seam (fig-18)

6.3.5 Welt seam: Welt seam is used to cover or bind the fabric edges. This seam looks like flat felled seam, but it is easier to make welt seam is use with fabric which do not fray and it is a great seam for bulky

How to make welt seam: First take two piece of fabric and stitch a plain seam with right side together. Trim the seam allowance of the one side $\frac{1}{2}$ inch at the edges then press that side of seam allowance now turn to the other side and stitch along the raw edge.



Welt seam (fig-19)

6.3.6 Piped seam (corded seam): In this seam two piece of fabric covered by cord between the seam lines. For this seam bias or straight fabrics are used, which is matched with fabric colour and contrast colour. This cord is sewn inside with a zipper foot. Piping seam used in cushions, bags, purse and clothing.

How to sew piped seam: Baste cord on the right side of the fabric, and stitch aligning cording stitch line with seam line toward raw edge of fabric, placing the stitching just to the left of the cording stitches. Place the seam allowance between cording and right sides, then press.

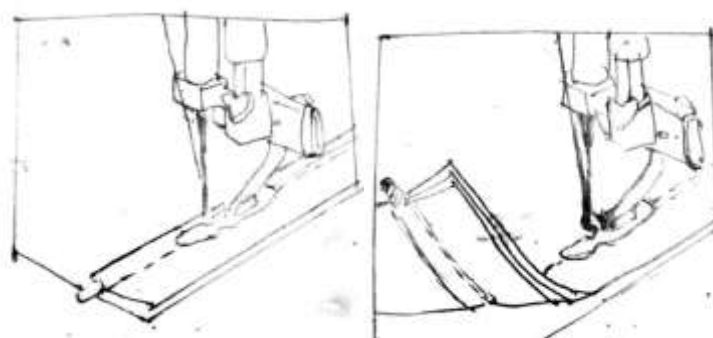

Piped seam (corded seam) (fig-20)

6.4 Check Your Progress

1. Write about uses of corner seam.

2. Give the information about basic seams.

3. In which fabric and garments French seam is used?

4. How to sew welt seam?

5. Write about piped seam.

6. Enlisting importance of seams.

6.5 Multiple Choice Questions

1) What is trimming?

- a) To increasing seam allowance
- b) To cut extra fabric from the seam
- c) To decreasing seam allowance

- d) To allow fabric as it in seams.
- 2) Which method is used for 2- 3 fabrics join with chains of stitches is called _____.
- a) Pleats
 - b) Seams
 - c) Frill
 - d) Fasteners
- 3) _____ seam looks like a flat felled seam.
- a) Plain seam
 - b) Corner seam
 - c) Curve seam
 - d) Welt seam
- 4) Flat felled seams is used in _____
- a) Blouse
 - b) Kurti
 - c) Baby frock
 - d) Jeans.
- 5) One side zipper foot is used for making _____ seam
- a) Piped seam
 - b) Plain seam
 - c) Corner seam
 - d) French seam

6.6 Let Us Sum Up

In sewing, a seam is the joint where two or more layers of fabric, leather, or other materials are held together with stitches. Prior to the invention of the sewing machine, all sewing was done by hand. Seams in modern mass-produced household textiles, sporting goods, and ready-to-wear clothing are sewn by computerized machines, while home shoemaking, dressmaking, quilting, crafts, haute couture and tailoring may use a combination of hand and machine sewing.

In clothing construction, seams are classified by their type (plain, lapped, abutted), and French seams and position in the finished garment (center

back seam, inseam, side seam). Seams are finished with a variety of techniques to prevent raveling of raw fabric edges and to neat the inside of the garments.

6.7 Key Words

Jab: insert

Concave: having an outline that curves inwards, hollowed out

Raveling: untangle, unlay, untwist

Convex: having an outline that curves out wards

Fabric edges: fabric boundary

Sturdy: well built, strong and solid

Fray: unravel

Couture: accessory, sewing fashion design, needle work, tailoring

Enlist: enroll in, sing up for, join, and take on

6.8 Suggested Books

5. Reader's Digest "Complete Guide to Sewing"
6. Singh, A and Bhardwaj, k (2012 "Textbook of clothing", vista international publishing house, Delhi) First Edition
7. Patel, V (2016 "Sewing technology", Sunrise Publication Co., Rajkot)
8. Dhruv publisher (2016-2017 "Sewing Technology and Dress Making" Ahmadabad) First Edition

Answers

6.4 Check Your Progress

1. Generally corner seam used in collar, v neckline, decorative patterns etc. in this seam corner should be blunted for better point result.
2. Basic seams mostly used in garment, because this is easiest seam to make. We can make it by Hand or machine. In this seam two edges are joint together entire length of seam. Generally plain seam is used for the finished fabric and also joint lining with garment.
There are three types of basic seam: **1) straight seam 2) curve seam 3) corner seam**

Straight seam: In this seam straight stitches are used the purpose of straight seam is joint to fabric edge. mostly plain straight stitch is used for joint.

Curve seam: This seam is used for curvature shape in garment like armhole neckline etc. curve seam requires careful guiding for same even distance from the edge. To use of shorter stitch length and slower machine speed. We can get better curve seam.

Corner seam: corner seam made with small stitches. Generally corner seam used in collar, v neckline etc. in this seam corner should be blunted for better point result.

3. French seam is use for clothing and children wear, ladies garment, under garment. It is generally use for shiny and thin fabrics like chiffon, organza georgette etc. We can get inner side clean finish in garment with help of French seam.
4. For sewing welt seam first you should take two piece of fabric and stitch a plain seam with right side together trim the seam allowance of the one side $\frac{1}{2}$ inch at the edges then press that side of seam allowance now turn to the other side and stitch along the raw edge.
5. In sewing technology piping is type of embellishment consisting of a strip of folded fabrics. In this seam two piece of fabric covered by cord between the seam lines. For this seam bias or straight cords are used, which is matched with fabric match colour or contrast colour. This cord is sewn inside with a zipper foot. Piping seam used in cushions, bags, purse and clothing. For sewing this seam baste cord on the right side of the fabric, and stitch aligning cording stitch line with seam line toward raw edge of fabric, placing the stitching just to the left of the cording stitches. Place the seam allowance between cording and right sides, then press.
6. Importance of seams mention in below:
 - **Strength:** The seam efficiency of the sewn seam should be so that sewn seam strength is balanced and can withstand the everyday usage of the garment.
 - **Elasticity:** Elasticity of sewn seam should be slightly greater than that of the material which it joins. This will enable the material to support its shape of the forces encountered for the intended end use of the sewn item. The elements affecting the elasticity and strength of a sewn seam depends upon fabric type and strength, seam type, stitch type, stitch density (SPI), thread tension, and thread strength and elasticity.
 - **Durability:** Durability of a sewn seam depends largely upon its strength relative to the elasticity of the seam and the elasticity of the material. For making a durable sewn seam, the thread size and stitch density must be carefully chosen to avoid puckering.

- **Security:** Security of sewn seam depends chiefly upon the stitch type, SPI, and its susceptibility to becoming unraveled. The stitch must be well set to the material to prevent snagging that can cause rupture of the thread and unraveling of certain stitch types.
- **Appearance:** Appearance of a sewn seam generally is governed by the proper relationship between the size and type of thread, the stitch density, and the texture and weight of the fabric.

6.5 Multiple Choice Questions

1. (a) 2. (b) 3. (d) 4. (d) 5. (a)

UNIT 7 SEAM FINISHES

7.0 Objectives

7.1 Introduction

7.2 Selection of Seam Finishes

7.2.1 Design And Use of The Garments

7.2.2 Shape of The Seam Finishes

7.2.3 Texture And Durability of The Fabric

7.2.4 Seam Allowance

7.2.5 Tension And Length of Stitches

7.2.6 Finishing of Seams

7.2.7 Current Fashion

7.2.8 Position and Shapes of Seam in The Garment

7.3 Types of Seam finishes

7.3.1 Double Top Stitch Finish

7.3.2 Pinked Seam Finish

7.3.3 Self-Bound Seam Finish

7.3.4 Bias Bound Seam Finish

7.3.5 Net Bound Seam Finish

7.3.6 Hand Overcast Seam Finish

7.3.7 Fagotted Seam Finish

7.3.8 Zigzag Seam Finish

7.3.9 Slot Seam Finish

7.3.10 Tuck Seam Finish

7.3.11 Check Your Progress

7.3.12 Multiple Choice Questions

7.3.13 Let Us Sum Up

7.3.14 Key Words

7.8 Suggested Books

Answer

7.0 Objectives

- To obtain information regarding types of seam finishes used in different fabric,
- To aware the students about how to sew the seam in a finishing way,
- Provide direction for seam used as a embellishment,
- Improving the life of a garment by use of right seam finishes.

7.1 Introduction

Seam finishes is a technique to prevent fraying and raveling of the raw edges and provide them neat and good appearance. Seams should be carefully done for a beautifully finished garment. It is a basic building block of a garment. They form the structure of the garment and help to create garment. Seam finishes also used as a decorative feature.

7.2 Selection of Seam Finishes

Seam finishes are used on a garment is depending on various factors.

- 7.2.1 Design and use of the garments** when making garment a strong decorative seam like tuck seam used in dresses etc.
- 7.2.2 Shape of the seam finishes:** seams finishes may be in vertical, horizontal or slanting direction on the dress. When joining edges, plain seam will give a better finish than French seam.
- 7.2.3 Texture and durability of the fabric:** when working with a heavy fabric, one should avoid bulky seam finishes
- 7.2.4 Seam allowance:** Seam allowance of material provided over and above the exact drafting to enable working of seams. The amount of seam allowance ranges from 1-1.5 centimeters depending again on the texture of the fabric.
- 7.2.5 Tension and length of stitches:** The tension and length of the stitch should be suitable to the thickness of the fabric.
- 7.2.6 Finishing of seams:** curve seams should be notched along the seam allowances after stitching to give a flat smooth finish.
- 7.2.7 Current fashion:** In current trend of the season must be considered while selecting the seams.
- 7.2.8 Position and shapes of seam in the garment:** stitching is always done on the fitting line perfectly. Therefore, stitching line of a seam forms the fitting line of the garment, which determines the shape and fit of a garment. And then garment with more stretch should give durable seam.

7.3 Types of Seam Finishes

7.3.1 Double top stitch finish:

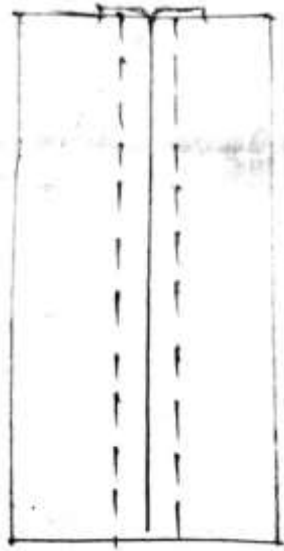

Double top stitch (fig-1)

This seam also called as clean finish. This seam can helpful on difficult fabric or curve fabric. This is for single layer fabric, not for bulky fabrics. These types of seams are more secure than other seams. Double top stitched seams are often used for blanket edges and pocket borders.

How sew double top stitch finish:

First make a plain seam, then press the both sides after opening it, then make an extra line for stitching at $\frac{1}{4}$ inch from the raw edge. Stitch along age of fold.

7.3.2 Pinked seam finish:

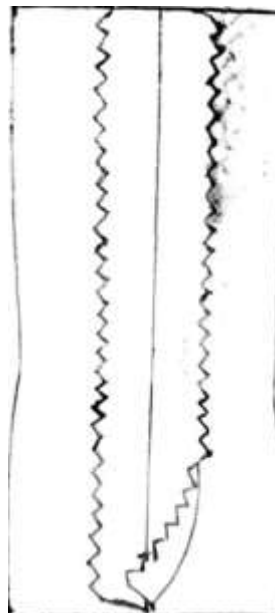

Pinked seam (fig-2)

Pinked seam is used with picking shears. Pinking looks attractive, very fast and easy

But this seam is not used in bulky fabrics and fabrics which are badly ravel.

How sew pinked seam finish:

First make a plain seam. Then trim the edge of seam allowance with pinking shear then press them open, by this way we can trimmed both side of fabric at once and save the time.

7.3.3 Self-bound seam finish:



Self-bound seam (fig-3)

Self-bound seam is looks like a tiny French seam, but the process of sewing this seam is completely different. This seam is great for light weight fabric that does not ravel easily. This seam is use for binding all the raw edges so that the inside of the garment looks clean.

How to sew self-bound seam:

First take two piece of fabric. Then sew the ½ inch wide seam allowance. Trim the top seam allowance. Fold the bottom, winder seam allowance over so that the raw edges almost meet the raw edges of trimmed seam allowances. Press the fold in to the seam allowance. Then stitch along the fold close to your seam.

7.3.4 Bias bound seam finish:

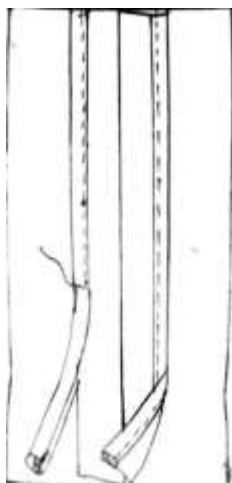

Bias bound seam (fig-4)

This is a simple way to finish the garment. Bias bound seam is specially used for finishing seam in an unlined jacket or coats. We can easily make the insides as good at the outside by using bias bounding. This seam will add some bulk in garment.

How to sew bias bound seam:

First take two pieces of fabrics and stitch the seam together. Sew the seam together, then open the seam and press it. Now pin a bias Patti at the one side of the seam allowances and sew it on the back side now do same as another side. Then open the both side and press the seam, this seam will remain open the inside of the garment.

7.3.5 Net bound seam finish:

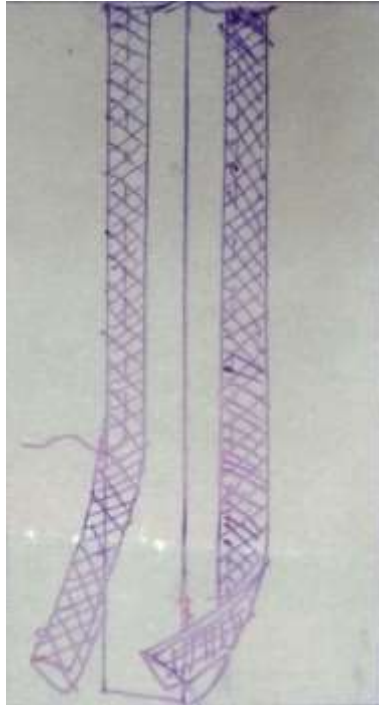

Net bound seam (fig-5)

This seam is generally use in delicate fabrics like a chiffon or velvet. In this seam the net use is very thin, and light weighted.

How to sew net bound seam:

The sewn process of this seam is same as bias binding seam finish. So, take two pieces of fabric, and sewn it together. Then open the edge of both seam side and trim notches, now wrap the net around the edge with wider half underneath and start to stitch from the top side to end side. Do same as another edge seam side. And then open the both sides.

7.3.6 Hand overcast seam finish:

This seam is used to enclose raw or unfinished seam or edge. An overcast seam is used in generally finishing edges, eyelets and cut work also used in blankets. There is different kind of overcast stitches. Use this seam when a machine finish is impractical, or hand finish required. To create overcast stitch by machine we can use and overcast foot. This seam is used in handkerchief and also in embroidery.

How to sew hand overcast seam finish:

By hand:

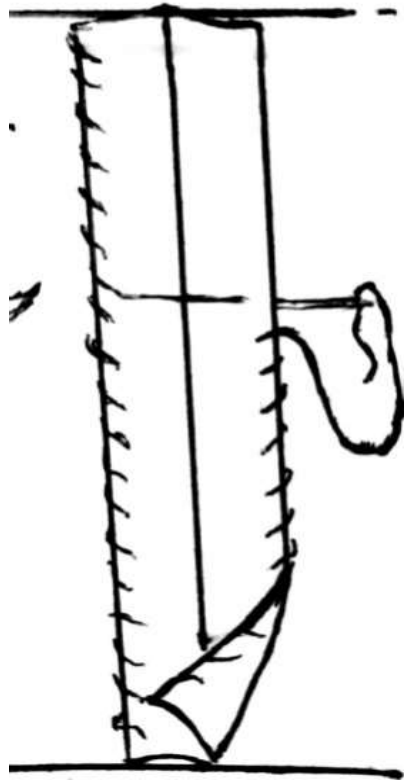

Hand overcast seam (fig-7)

First take a fabric and fold the edge as thin as possible. Then bring the needle out from back to front through the fold now take the needle and thread over the other side of the fabric from $\frac{1}{4}$ inch bring the needle out to the front of the fabric notice that the stitch has enclosed the fabric edge. Generally in this seam small diagonal and evenly spaced out stitches are involved at the fabric raw edge.

By machine:

The machine overcasting stitch gives flat and even stitches finishing the fabric edges very neatly. In this method first stitch plain seam and then finish edges with overcast stitch you can do the reverse also for this stitch make the two edges together, and sew the regular plain seam on the seam allowance line. Usually the seam allowances are separated and each seam is given an overcast edge. Then the seam is pressed open. Turn by turn both edges can be stitched together as well and pressed to one side. You can sew a neat enough overcast stitch with a regular foot but a special overcast foot is convenient to have. The thin bar that sticks in the centre front of this foot helps you keep the fabric perfectly lined up with the needle. This edge guide helps you to feed the fabric evenly along the raw edge. The bar in the middle of the foot is there for a reason the needle goes over this bar when stitching and keeps the fabric from puckering bunching up onto itself as you sew, especially if the stitch becomes tight. These stitches are perfect for sewing knit fabric as well as woven fabrics.

7.3.7 Fagoted seam finish:



Fagoted seam (fig-7)

Fagoted seam also known as twisted insertion stitch. Fagoted seam technique is use to join the panels together of two fabric with a gap in between them using some fancy needle work. It is a decorative seam. This seam used in most often in vintage clothing with pretty detailing. This seam can be use in skirts, blouse, Kurtis, tops etc.

How to sew Fagoted seam:

First take two pieces of fabric and turn the seam allowance under on each side of the seam and stitch at the edge of the fabric pieces. Turn the allowance down a long with row stitching and press. Stitch even zigzag stitches between the edge's outer points. First make a stitch to determine width of opening. Then divide this width in half and fold each seam line back by this halved amount. Now draw a parallel line on a paper with a use of pencil between folded edges then pin refolded fabric to paper with parallel lines. Now stitch zigzag center opening under foot and make sure that each edge is caught in stitching

7.3.8 Zigzag seam finish:

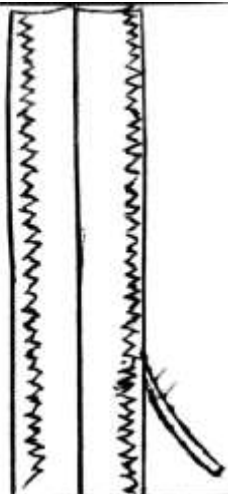

Zigzag seam (fig-8)

A zigzag seam finish can be used to enclose the raw edge and prevent fraying. This seam can be used for knit. We can easily stitch zigzag edges using a sewing machine. There is no special equipment required but an overcast foot can be helpful to get this stitches guide on the edge of the fabric

How to sew zigzag seam finish:

you may choose a colour of the thread that matches or contrast with your fabric, when sewing these seam. Now set your machine to the zigzag stitch setting it is a common stitch that all sewing machine have. Now trim close to stitching.

7.3.9 Slot seam finish:

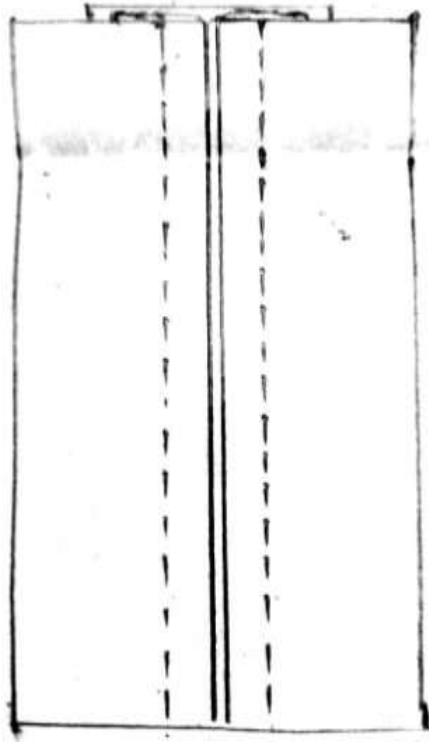

Slot seam finish (fig-9)

This seam is similar to the lapped seam. A slot seam is used in pockets, blouses, dresses, jackets and coats. It is decorative seaming technique. It is easy to make any normal seam into a slot seam. And there is no need to make any alterations to the project to accommodate it.

How to sew slot seam finish:

Take two piece of fabric and sew at the edge of both piece of the fabric. Then keep the fabrics facing each other right side and pin them together. Now take a seam machine baste on the seam line. After this turn the joint fabric and open the seam allowance and press it. Now take 1 ½ inch wide and same length fabric which can be in same colour or contrast colour, and finish its raw edges. Now keep this fabric at the back side of the middle of the main fabric joint and pin it. Then turn the main fabric on a right side and stitch both side the plain seam, at the ¼ inch from the center line. Then pull out basting threads.

7.3.10 Tuck seam finish



Tuck seam (fig-10)

This seam is a fold or pleat in fabric that is sewn in place. When the tucks are very narrow, they are called as pin tucks. Tuck seam generally used to decorate clothing or household linens. It is also used in children garment.

How to sew tuck seam finish:

First take a fabric piece and mark tuck line with its corresponding description then fold the

Fabric under one seam allowance and press it. Now match the seam line baste with folded

Edge on the top through all thickness. Now stitch $\frac{1}{4}$ inch from the fold.

First stay stitch top

Seam allowance and clip them press it to wrong side. Then baste in position and make top

Stitch close to the fold.

7.4 Check Your Progress

1. What is double top stitch seam?

2. What is used for picked seam?

3. What is bias bound seam?

4. Give information about Fagoted seam

5. Write about tuck seam

7.5 Multiple Choice Questions

1) This is appropriate finish for velvet or chiffon fabrics.

- a) Net bound finish
- b) Stitched and pinked finish
- c) Pinked finish
- d) Zigzag finish

2) _____ seam is similar look like tiny French seam

- a) Self-bound seam
- b) Bias bound seam
- c) Double top stitch seam
- d) Fagoted seam

3) Which seam give reversible effect in fabric?

- a) Hand overcast seam
- b) Bias bound seam
- c) Slot seam
- d) Tuck seam

4) In which fabric net bound seam is used

- a) Chiffon
- b) Velvet
- c) Georgette
- d) All of them

5) Which seam similar as lapped seam

- a) Slot seam
- b) Plain seam
- c) Corner seam
- d) Net bound seam

7.6 Let Us Sum Up

Seam finishes play an important role in garment construction. The type of seam finish is depending on the type of fabric, the strength, and type of the seam, and the expected effect desired. Whatever may be the factors a seam finishes should provide strength and neat appearance to the garment.

7.7 Key Words

Insertion: placing, addition

Faggoted stitch: the stitch that ties a group of parallel threads together in faggoting.

Tiny: small

Bulky: large, quantity, voluminous, solid

7.8 Suggested Books

- 1) Singh, A & Bhardwaj, k (2012 “Textbook of clothing”, vista international publishing house, Delhi) First Edition
- 2) Reader’s Digest “Complete Guide to Sewing”
- 3) Patel, V (2017 “Sewing technology”, Sunrise Publication Co., Rajkot)
- 4) Dhruv publisher (2017-2017“Sewing Technology and Dress Making” Ahmadabad) First Edition

Answers

8.4 Check Your Progress

- 1) Double top stitch seam called as clean finish. This seam can helpful on difficult fabric or curve fabric. Double topstitch is single layer fabrics. it is not for bulky fabrics. This seam is neat and tailor finish seam. This seam use for medium weight fabrics.
- 2) Pinked seam is used with picking shears. Pinking looks attractive, and very fast and easy but, this seam is not used in bulky fabrics and fabrics which are badly ravel. Picked seam uses in raw edges and finishing of garments.
- 3) Bias bound seam is a simple way to finish the garment. Bias bound seam is specially used for finishing seam in an unlined jacket or coats. We can easily make the insides as good at the

outside by using bias bounding. Bias bound seam will add some bulk in garment

- 4) Fagoted seam is known as twisted insertion stitch. Fagoted seam technique is use for joint the panels together of two fabric with a gap in between them using some fancy needle work. It is a decorative seam. fagoted seam used in most often in vintage clothing with pretty detailing. This seam can be use in skirts, blouse, kurtis, tops etc. fagoted seams is decorative seam
- 5) Tuck seam is one kind of fancy seam. It is fold or pleat in fabric that is sewn in place. When the tucks are very narrow, they are called as pin tucks. Tuck seam generally used to decorate clothing or household linens. It is also used in children garment to finished shorten. And used to decorate heavier fabrics Tucks were very popular as ornamentation in the letter half of the 19th century.

8.5 Multiple Choice Questions

1. (a) 2. (a) 3. (a) 4. (d) 5. (a)

युनिवर्सिटी गीत

स्वाध्यायः परमं तपः

स्वाध्यायः परमं तपः

स्वाध्यायः परमं तपः

शिक्षण, संस्कृति, सद्भाव, दिव्यबोधनुं धाम
डॉ. बाबासाहेब आंबेडकर ओपन युनिवर्सिटी नाम;
सौने सौनी पांभ मणे, ने सौने सौनुं आत्म,
दशे दिशामां स्मित वडे छो दशे दिशे शुभ-लाभ.

अत्मण रडी अज्ञानना शाने, अंधकारने पीवो ?
कडे बुद्ध आंबेडकर कडे, तुं था तारो दीवो;
शारदीय अजवाणा पळोंच्यां गुर्जर गामे गाम
ध्रुव तारकनी जेम जणहणे अकलव्यनी शान.

सरस्वतीना मयूर तमारे इणिये आवी गळेडे
अंधकारने हडसेलीने उजसना झूल मळेंडे;
बंधन नहीं को स्थान समयना जवुं न घरथी दूर
घर आवी मा हरे शारदा दैन्य तिमिरना पूर.

संस्कारोनी सुगंध मळेंडे, मन मंदिरने धामे
सुषुप्ती टपाल पळोंये सौने पोताने सरनामे;
समाज केरे दरिये लांडी शिक्षण केरुं वडाण,
आवो करीये आपण सौ
भव्य राष्ट्र निर्माण...
दिव्य राष्ट्र निर्माण...
भव्य राष्ट्र निर्माण

CERTIFICATE / DIPLOMA IN FASHION DESIGNING



BASIC SEWING TECHNIQUE
CFD/DFD-01

Block-2



Message for the Students

Dr. Babasaheb Ambedkar Open (University is the only state Open University, established by the Government of Gujarat by the Act No. 14 of 1994 passed by the Gujarat State Legislature; in the memory of the creator of Indian Constitution and Bharat Ratna Dr. Babasaheb Ambedkar. We Stand at the seventh position in terms of establishment of the Open Universities in the country. The University provides as many as 54 courses including various Certificate, Diploma, UG, PG as well as Doctoral to strengthen Higher Education across the state.



On the occasion of the birth anniversary of Babasaheb Ambedkar, the Gujarat government secured a quiet place with the latest convenience for University, and created a building with all the modern amenities named 'Jyotirmay' Parisar. The Board of Management of the University has greatly contributed to the making of the University and will continue to this by all the means.

Education is the perceived capital investment. Education can contribute more to improving the quality of the people. Here I remember the educational philosophy laid down by Shri Swami Vivekananda:

“We want the education by which the character is formed, strength of mind is increased, the intellect is expand and by which one can stand on one’s own feet”.

In order to provide students with qualitative, skill and life oriented education at their threshold. Dr. Babaasaheb Ambedkar Open University is dedicated to this very manifestation of education. The university is incessantly working to provide higher education to the wider mass across the state of Gujarat and prepare them to face day to day challenges and lead their lives with all the capacity for the upliftment of the society in general and the nation in particular.

The university following the core motto ‘स्वाध्यायः परमम् तपः’ does believe in offering enriched curriculum to the student. The university has come up with lucid material for the better understanding of the students in their concerned subject. With this, the university has widened scope for those students who are not able to continue with their education in regular/conventional mode. In every subject a dedicated term for Self Learning Material comprising of Programme advisory committee members, content writers and content and language reviewers has been formed to cater the needs of the students.

Matching with the pace of the digital world, the university has its own digital platform Omkar-e to provide education through ICT. Very soon, the University going to offer new online Certificate and Diploma programme on various subjects like Yoga, Naturopathy, and Indian Classical Dance etc. would be available as elective also.

With all these efforts, Dr. Babasaheb Ambedkar Open University is in the process of being core centre of Knowledge and Education and we invite you to join hands to this pious *Yajna* and bring the dreams of Dr. Babasaheb Ambedkar of Harmonious Society come true.



Prof. Ami Upadhyay
Vice Chancellor,
Dr. Babasaheb Ambedkar Open University,
Ahmedabad.

Editor

Prof. (Dr.) Ami Upadhyay
Vice Chancellor
Dr.Babasaheb Ambedkar Open University, Ahmedabad

Dr.Awa Shukla
Assistant Professor (Subject Head)/ Director (I/c) Student Services
Dr.Babasaheb Ambedkar Open University, Ahmedabad

Programme Advisory Committee

Prof. (Dr.) Ami Upadhyay
Vice Chancellor
Dr.Babasaheb Ambedkar Open University, Ahmedabad

Dr.Awa Shukla
Assistant Professor (Subject Head)/ Director (I/c) Student Services
Dr.Babasaheb Ambedkar Open University, Ahmedabad

Dr. Rajshree Yadav
Prof. (CACDDM)
Government Girls College,Ahmedabad

Dr. Hemalata Patel
Prof. (Home-Science)
Mahila Home-Science College, Mahesana

Ms. Devyani Dhandhukiya
Fashion Designer & Freelancer, Ahmedabad

Reviewers

Dr. Rajshree Yadav
Prof. (CACDDM)
Government Girls College,Ahmedabad

Dr. Hemalata Patel
Prof. (Home-Science)
Mahila Home-Science College, Mahesana

Content Writers

Ms. Donika P. Patel

Programme Coordinator

Dr.Awa Shukla
Director (I/c) Student Services
Dr.Babasaheb Ambedkar Open University, Ahmedabad

Publisher

Dr.Bhavin Trivedi
Registrar (I/c), Dr.Babasaheb Ambedkar Open University, Ahmedabad

ISBN-978-93-89456-70-7

All rights reserved. No part of this work may be reproduced in any form, by mimeograph or any other means without permission in writing from Dr. Babasaheb Ambedkar Open University, Ahmedabad.



Dr. Babsaheb Ambedkar Open University

(Established by Government of Gujarat)

**CERTIFICATE/DIPLOMA IN FASHION DESIGNING
DESIGNING BASIC SEWING TECHNIQUE**

CFD-01/DFD-01

Block

2

Unit 8

Principles of Fullness

Unit 9

Neckline Finishing

Unit 10

Pockets and Yoke

Unit 11

Sleeves

Unit 12

Collars

Unit 13

Plackets

Unit 14

Fasteners

Unit 8- Principles of Fullness

8.0 Objectives

8.1 Introduction

8.2 Importance of Fullness in Garment

8.3 Types of Fullness

8.3.1 Pleats

8.3.1.1 Different Types of Pleats

- **Side (Knife) Pleats**
- **Box Pleats**
- **Inverted Pleats**
- **Accordion Pleats**
- **Pleats With Separate Underlay**
- **Kick Pleats**

8.3.2 Tucks

8.3.2.1 different Types of Tucks

- **Blind Tucks**
- **Pin Tucks**
- **Spaced Tucks**
- **Corded Tucks**
- **Cross Tucks**
- **Shell Tucks**
- **Released or Dart Tucks**
- **Twisted Tucks**

8.3.3 Darts

8.3.1 Different Types of Darts

- **Single Darts/Plain Darts**
- **Double Pointed Darts/ Contours Darts**
- **French Darts/ Bust Darts**
- **Skirt/Pants Darts**

8.3.4 Gathers

8.3.4.1 Different Types of Gathers

- **Gathering By Hand**
- **Gathering By Machine**
- **Gathering By Elastic**
- **Automatic Gathering**

8.3.5 Smocking

8.3.6 Shirring & Gauging

8.3.7 Godets

8.4 Method of Adding Fullness to the Garments

Check Your Progress

Multiple Choice Questions

8.5 Let Us Sum Up

8.6 Key Words

8.7 Suggested Books

Answers

8.0 Objectives

- In this Unit, you will able, understand the knowledge on different types of fullness in garments.
- To make the students aware about how to apply methods of fullness technique.
- To identify various methods for different age groups garments.
- To make them Understand for current fashion fullness technique in fashion garments.
- To gain knowledge about how to calculate the extra fabrics in clothing constructions.

8.1 Introduction

Fullness of material is a significant component of the style just as a need for simplicity of development in an all-around fitted piece of clothing. Design changes the basic techniques of controlling fullness that as often as possible repeat, however adjusted to improve the current style. Darts, tucks, pleats, and gathers ruffles etc. are a portion of the techniques for presenting Fullness. fullness is brought into articles of clothing for different reasons, for example,

- To give great shape and proper fit to the clothing
- To enable opportunity of development and comfort to the wearer, and
- To make the piece of clothing looks good

8.2 Importance of Fullness in Garment

Fullness is the term utilized in sewing for the different procedures that are utilized to take out the fullness or fabric in your works. Discarding fullness should be possible to offer shape to an article of clothing, add design to highlights or to make a piece of clothing fit. In garment construction not only two sections of piece of cloth are joined but also sections give shape to the body to give fit and comfort. There are different ways in which pieces of clothing are shaped upon on the amount of curve required in the garment and the design of the garment. Shaping is done by one of the methods of fullness.

8.3 Types of Fullness

8.3.1 Pleats

Pleats are presented usually at the waistline of skirts and dresses, to provide equally fullness all around. The preparation of pleats is like that of tucks, the main difference being that pleats are only from time to time sewed up to down. Sometimes they are sewed part path down the article of clothing for flatness. Each pleat requires additional material of double the width of the completed pleats. If pleats are to contact each other all round the garment, the measure of material is required multiple times to complete the width. Firm and fresh textures can hold pleats better. The pleats are of various sorts. Pleats are fold in fabric that give controlled fullness pleats may happen as a one pleats, as a bunch, or around a whole garment area.

8.3.1.1 Different Types of Pleats

- **Side (knife) pleats**

Knife pleats can be utilized as an option. These pleats generally have a width of around 1/2–2" and are turned towards a similar direction. Figure sketch a skirt with knife pleats.

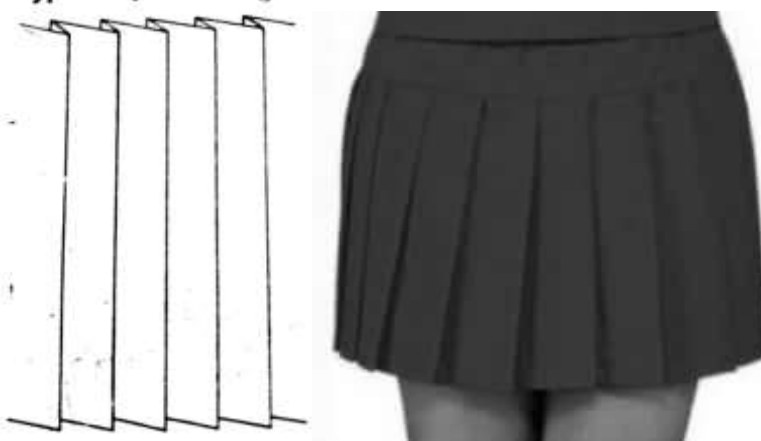

Knife pleats (fig-1)

- **Box pleats**

A Box pleat is formed when two consecutive knife pleats are folded in opposite directions – one to the left and one to the right. This is used in frocks and skirt waistline. A skirt with box pleats is shown in Figure.

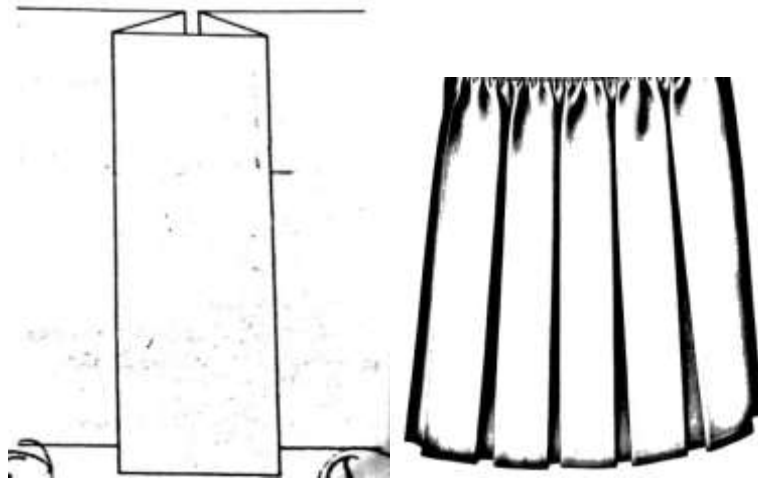

Box pleats (fig-2)

- **Inverted Pleats**

Inverted pleats are opposite of a box pleat. It is made up of two knife pleats turned towards one another, so the folds meet on the correct side of the garments. It is generally designed at centre front or centre back and looks like two knife pleats facing away from another on the underside.

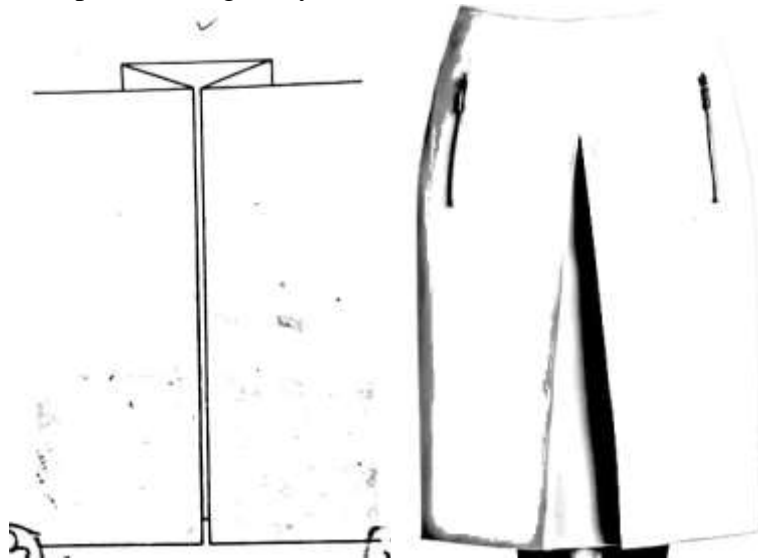

Inverted box pleats (fig-3)

- **Accordion Pleats**

Accordion pleats are a progression of extremely restricted and straight pleats of equivalent width. These folds have a striking similarity to the bellows of an accordion, hence the name. The width of the pleats ranges from 3 to 13 mm. These pleats are near one another and have a uniform depth from the waist to hem.

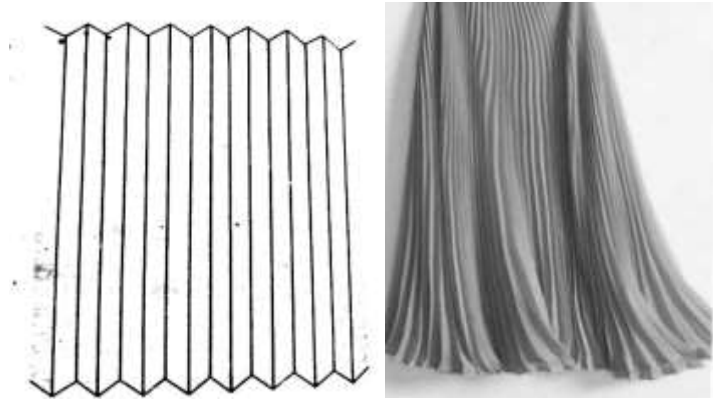

Accordion pleats (fig-4)

- **Pleats with Separate underlay**

These pleats on the wrong side of the fabric and the split in down the centre on the front. Presently for something truly cool, you can make inverted pleat with a separate underlay. (The underlay is the piece of the texture that tops through the centre opening.)

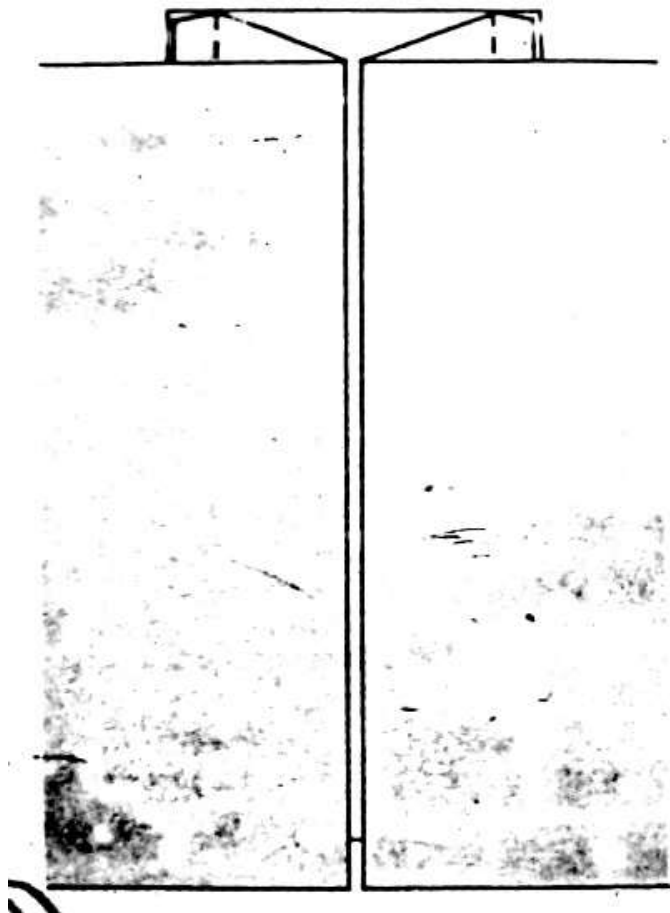

Separate underlay pleats (fig-5)

- **Kick Pleats**

These are inverted pleats joined along the fold edges a short distance from the top. In skirts the kick pleats are joined till the hips.



Kick pleats (fig-6)

8.3.2 Tucks

Tucks are utilized for decorative purposes and are an incredible method to include design any garments. Tucks are made by straight sewing an overlay of fabric. Probably the most common tucks are pin tucks, dart tucks, blind tucks and space tucks. These tucks are exceptionally basic and come in various widths and alignments. Since a tuck is represented by a single fold, the width of the tucks is measuring the good ways from the overlay to the sewed line. The tuck's overlap can be found either within or outside of the garments.

Before we begin on the sewing steps, you must understand tucks and its types.

Tucks are only an overlap of the fabric sewed by running stitch or machine stitch on the correct side of the garment. The purpose of tucks to the body, for hold fullness and to adds decorative effect to the garment like shoulders, waistline, yokes, pockets or cuff sleeves etc. They can be sewed in groups, independently or in graduated width. The following are some different types of tucks.

8.3.2.1 Different Types of Tucks

- **Blind Tucks**

Overlap the stitching on another tuck.

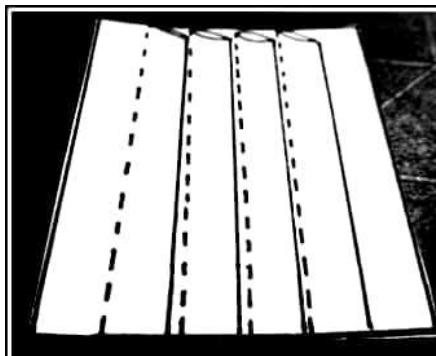

Blind tuck (fig-7)

- **Pin Tucks**

These are very tiny tucks that may be done by hand with tiny running stitches or by machine. They are commonly used on baby clothes and fine blouses. They are usually less than 1/8 inch wide



Pin tucks (fig-8)

- **Space and Bubble Tucks**

Tucks are made by folding the fabric and sewing straight stitching lines along the folded fabric edge, like you would sew pleats. You can make wide tucks as well as narrow tucks. Generally, space tucks are made in 1/4-inch width. You can use the 1/4-inch quilting foot to get these tucks perfectly.

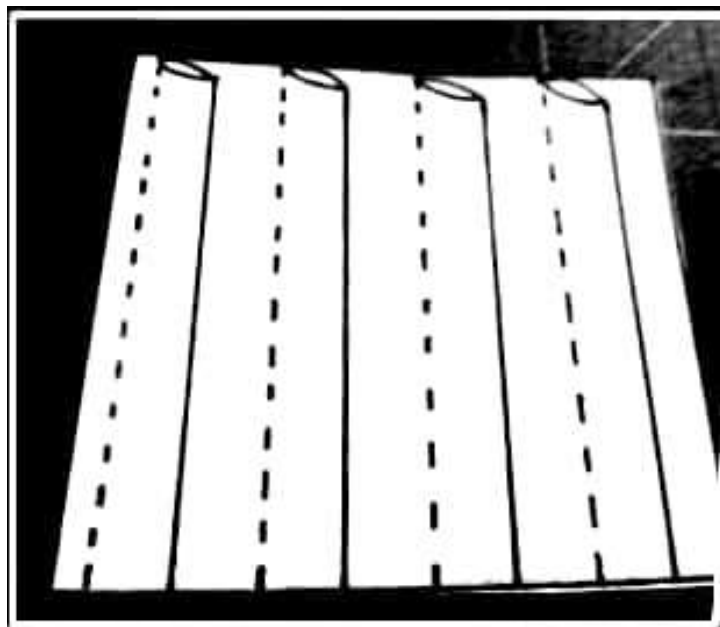

Space tucks (fig-9)

- **Corded Tucks**

These are made by placing cording on the wrong side of the fabric at centre of tuck before stitching the tuck. Stitching should be done close to cording.

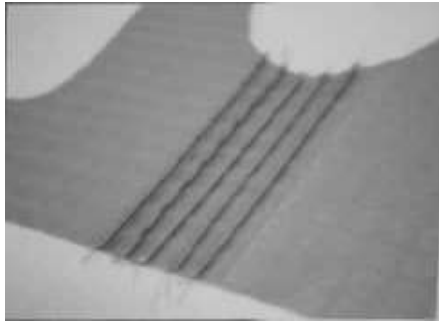

Corded tuck (fig-10)

- **Cross Tucks**

When rows of tucks are stitched along the fabric in both horizontal and vertical directions, the decoration is called cross tucking. First stitch the vertical tucks and presses them to one side. Then stitch the horizontal tucks.

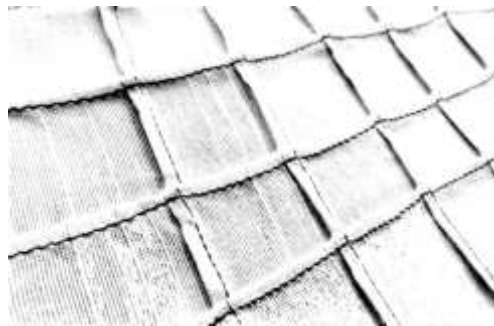

Cross tuck (fig-11)

- **Shell Tucks**

This is a very decorative tuck made by hand. Mark and crease the fabric as for a straight tuck of about $\frac{1}{4}$ inch wide. On the line of stitching, mark uniformly spaced dots about $\frac{1}{2}$ inches apart. Stitch the tuck using small running stitches. As you come to each dot, take two overcast stitches through the dot and pull tightly before proceeding further with the running stitches.

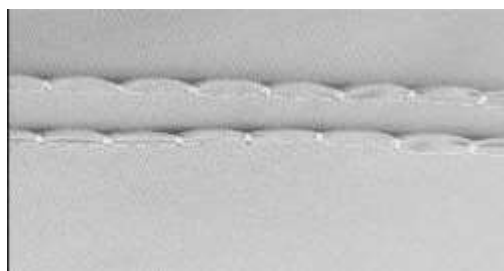

Shell tucks (fig-12)

- **Released or Dart Tucks**

These are the kinds of tucks usually seen in clothes to contain the fullness. These tucks are sewn a few inches and then stopped so that upper part where the tucks are made will take in the fabric.



Released or dart tuck (fig-13)

- **Wave Tucks**

These are simple tucks sewn across the fabric and then stitched down in a back and forth manner making waves



Wave tucks (fig-14)

How to make wave tuck:

Mark fabric for space tucks; Mark the fabric opposite to the space tucks, middle from one another for transversely sewing.

Sew the space tucks. Initially begin sewing through the lines you have marked, keeping the folds went to the other side. This will make one lot of twists/waves. Initially we need to make the original twist.

Sew over the centre of every section of tucks with the tucked folds contorted down/opposite direction.

You can sew as you go or overlay each fold, pin and after than sew. One should try not to pin up, simply sew folding individual tucks by hand.

8.3.3 Darts

Darts are construction specified that shape fabric to the curves of the body. Darts can be straight (for a simple fit) or curved (for a closer-to-the-body fit). Darts are mainly found in the bust, hip and waist area. Beautiful darts may fill this functional purpose as well as add significance to the design. While making a dart the length of the dart and width of the dart must be considered. Functional darts are those that are needed for fitting of body curves. Darts can be classified as functional or decorative and sometimes some darts serve both the purpose.

8.3.3.1 Different Types of Darts

- **Single Darts/Plain Darts**

Single darts are probably the most common kind of dart in home sewing. Single dart is normally found in bodice block. For example, bust line dart, waistline dart, armhole dart and centre front darts. It is more extensive at the base and tapers to the tip in shape. It is sewed on a wrong side of the garments. To make this dart, move the dart stamping of the paper example to the texture, locate the middle point on the wide finish of the dart, and make an overlay to the tip of the dart, keeping the correct side of texture together.

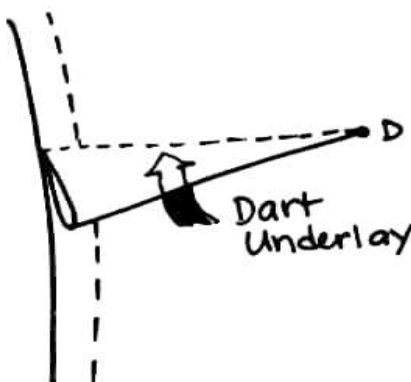

Single dart (fig-15)

- **Contour Darts/ Double Pointed Parts**

Double pointed darts are seen in diamond shape. You can see contour darts utilized on longer garments styles, like a tunic, jacket or dress. They can be sewn on the front and additionally the back. They include shape at the bust, waist and hips at once. The example piece beneath is the back of a coat, where contour darts are utilized to include shape at the waist back.

Double pointed darts are essentially two single darts consolidated. Start sewing the double darts from the centre and sew to one end. Return to the centre and sew to the opposite

end. Ensure that the centre sewing is covering and without distortion.

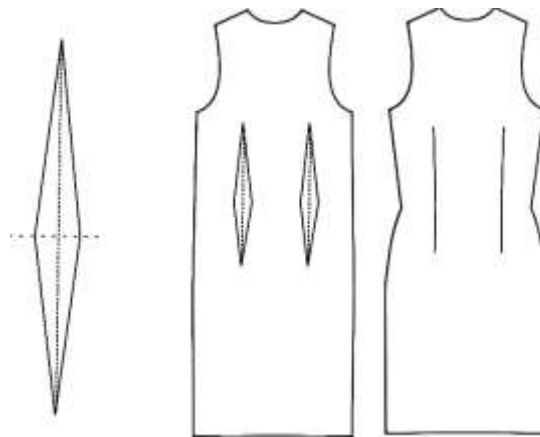

Double pointed dart (fig-16)

- **French Darts/ Bust Darts**

French darts are more lengthened than standard bust darts. They begin lower on the bodice (along the side seam, down close to the waistline) and end up close to the bust point — adequately joining a bust dart and waist dart into one. They are some of the time seen on more vintage styles, but if u wants to used one in Morden design garments.



French dart (fig-17)

- **Skirt/Pants Darts**

These are darts starting at the waist and going towards the hip to create fullness there. They are placed in the back of a skirt to give a smooth fit from the waist and over the hips. You can cut the yoke such that the darts are unnecessary.



Skirts dart (fig-18)

8.3.4 Gathers

Gathers are beautiful folds of fabric that gives fullness, recommending a delicate look, which can be made through utilization of machine or hand stitches. These are framed by drawing the fabric together on a line of sewing. Fullness used at round waist, yoke lines, neck lines and upper and lower edge of sleeves.

8.3.4.1 Different Method of Gathering

- **Gathering by hand**

Making Two rows of running stitch of 1/4 inch separated. The closures of threads are drawn until the segment measures the ideal length. The thread is verified by twisting cycle a pin as shown.

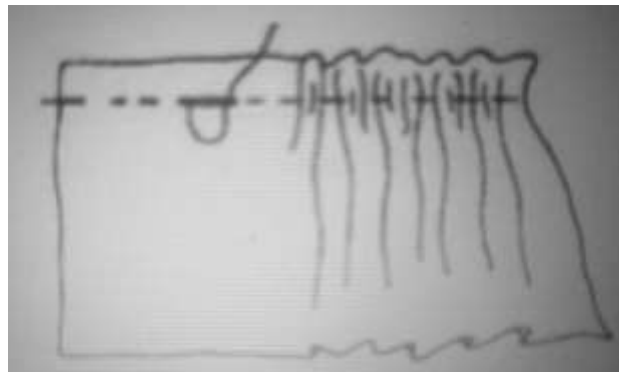

Gathering by hand (fig-19)

- **Gathering by Machine**

Make seam line on the correct side of the texture by changing the machine for long stitch and extricating the upper tension slightly. Make a few columns of little join on either side of the seam line on the area to be gathered

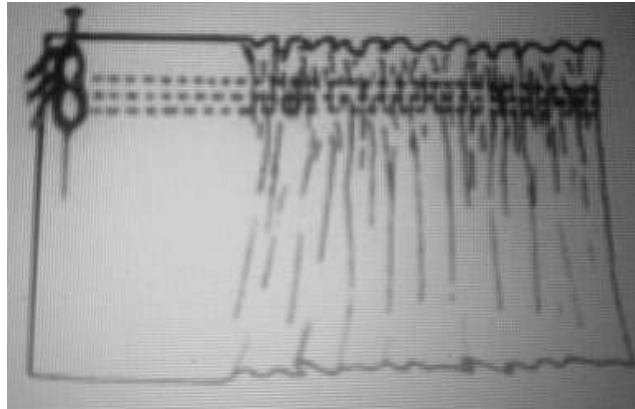

Gathering by machine (fig-20)

- **Gathering by Elastic**

Gathers can be made by stretching a narrow piece of elastic and sewing on the garment which is to be gathered.

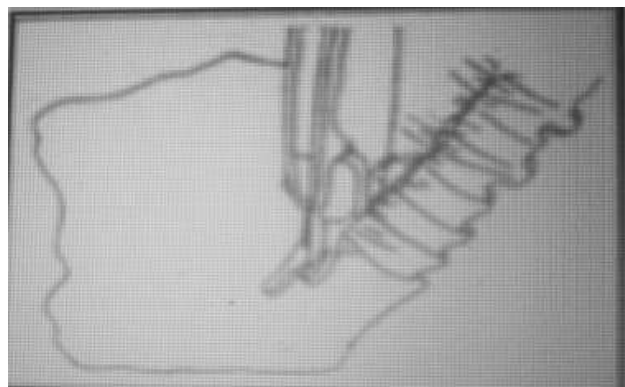

Gathering by elastic (fig-21)

- **Automatic gathering**

Automatic gathering is performed while sewing rather than organizing the fabric afterwards. It requires the utilization of either a gathering foot or a more complicated ruffle. Both lock and additional piece of fabric into the stitches as sewing is done.

Check your progress I

1. Enlist kinds of tucks.

2. Write about different methods of gathering

3. Enlist different types of darts.

8.3.5 Smocking

It is a sort of texture advancement, comprising of small weaving lines sewn over the folds of gathers at consistently divided interims on the correct side of the fabric. It is utilized to hold fullness or to add surface and texture interest to a bodice, neck area or sleeves of youngsters' or ladies' dress. Most appropriate textures for smocking are delicate and level confronted textures, for example, voiles, cambric and crepes. Utilize a medium-weight fabric and twisted threads of cotton or silk.



Smocking (fig-22)

What is smocking?

Smocking is a structure system to control the fullness in clothes, with excellent embroidery stitch. To do smocking, ordinary gathers (or pleats) are taken on the fabric with long fastens on the back and little join in the front.

Best fabric for smocking?

Crepe, silk, linen, cotton, gingham, velvet, chiffon, ribbon, and weaves pare belt for smocking. You name the texture and it has been smocked by ladies before times. Medium weight woven fabric with a smooth surface is perfect for smocking. You can select plain or printed cotton, poplin, cotton, silk, glossy silk, cotton blends, organdie, lightweight denim and lightweight wool.

How much additional material is needed to do smocking?

You need at least multiple times the material for the width of the last piece. You need a final smocked piece of 10 inches, you must take 30 inches

material to do smocking. In any case, it also depends on the tightness of the smocking lines. If you make slack lines the less material required. Include the seam allowance too.

Which thread is best for smocking?

Smocking stitches are finished with normal embroidery thread. On silk garments use silk thread and on cotton fabric use cotton thread. Shade of the thread and Pastel colours work is best on light shaded fabrics. Keep the thread close to your fabric to check whether it suits or not. A couple of colours, a few shades, of similar colours, are favoured for smocking. One can utilize three strands of string for the smocking fastens; for a thicker impact you can pick four strands.

Preparation of fabric for smocking

Smocking on plain material requires checking with a progression of dots on the off-base side these dots must be equitably divided, around 0.3 cm separated, and the separation between the columns might be 0.5 – 1 cm. For heavy fabric the separation can be more. Fabrics with checks, plaids or dots do not require the exchange of the pattern. Utilizing solid thread, get the dots along one line and make a few running stitches along. Complete every one of the rows. The number of lines depends upon the area to be covered. The width of the fabric should be multiple times as long as it gathers fabric for smocking. Draw up the fabric on the thread and fix the thread closes by winding them together round the pins set toward one side to hold them safely.

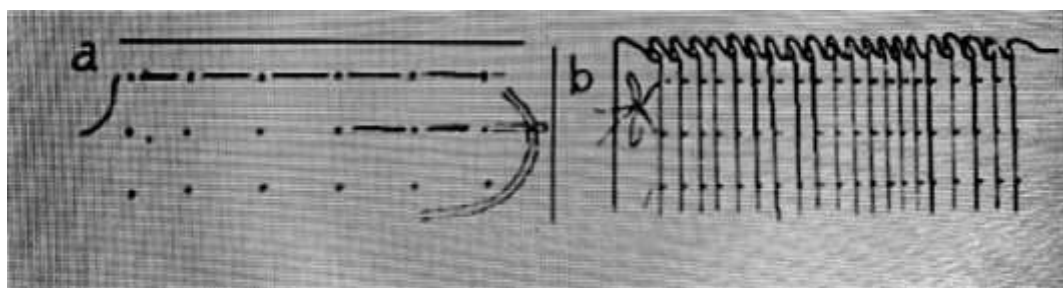

(Fig-23)

Stitches used for Smocking

Each stitch is worked from left to right. Ample quality of embroidery threads of appropriate colours are utilized for smocking.

- **Outline stitch**

This resembles a stem stitch used to make outlines. Work each line over the rounded fabric folds. Take out needle on the main fold on the extreme left by making small back stitch over the fold. While making the stitch, consistently hold the string under the needle. Draw up each overlap solidly, after each line.

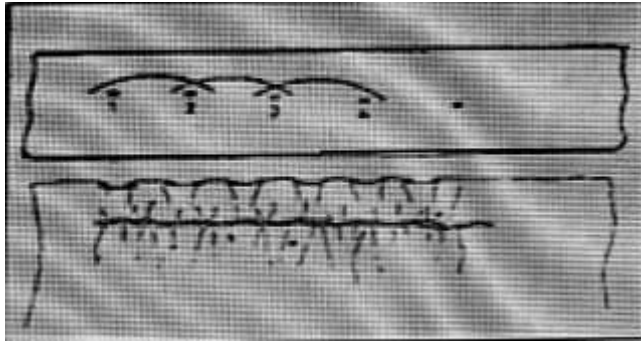

Outline stitch (fig-24)

- **Cable Stitch**

It is a variety of diagram line done in two close lines. Begin similarly with respect to the outline stitch. While taking line, keep the thread over the needle for the main stitch and underneath the needle for the second, and repeat all through the length of the line.

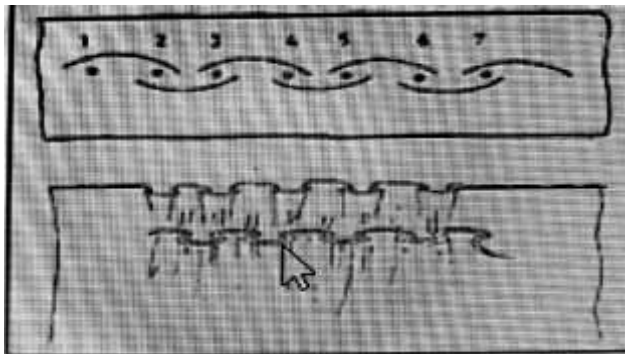

Cable stitch (fig-25)

- **Wave Stitch**

To make wavy impact, make odd number (5, 7, or 9) of framework lines corner to corner upward and afterward descending. For the upward column keep the thread underneath the needle and for the descending line keep the thread over the needle. Revise the procedure to make lines of diamond shapes or line of wavy structure.



Wave stitch (fig-26)

- **Chevron**

Chevron forms zigzag stitches over the folds. Take a stitch on the first pleat at the left of a row of gathering stitches, pass the needle down to the next row of gatherings and take another stitch in the same first fold. Then, over the same fold, take a stitch on the second fold, inserting the needle to the right. Bring it down between the first and second pleat. Keeping the thread below the needle, draw this stitch up so that the two pleats are held closer. Then pass the needle up to the first row, take a stitch over the second pleat, with the thread above the needle, take a stitch over the third pleat, bringing the needle out between the second and third pleat and draw the stitch tight. Make the second row of zigzag stitches in such a way that its points meet the points of the second row followed by the fold on the third row to form diamond design



Chevron (fig-27)

- **Honeycomb Stitch**

To begin with, bring the needle out in first pleats; take two minor backstitches over overlap to secure the thread. Pull the needle through the first fold about 0.5 cm beneath the first stitch, keeping the thread over the needle. With thread beneath the needle, put the needle during that time fold at a similar level. Draw the thread tightly together. Put the needle through a similar overlap at a similar level as the primary line. With thread over the needle, put the needle through the third overlay at a similar level. Draw tightly together are, Repeat till the finish of the line.

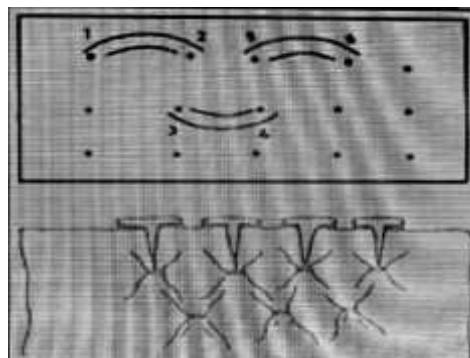

Honeycomb stitch (fig-28)

How to add smocked fabric to your clothes

There are two different ways of doing this. You can make the smocking on a pre-cut. Example Do the smocking on the texture and then cut the example.

The smocking stitch looks essentially however it can bring some exceptionally entangled on garments and accessories. These are result of consistency in making those basic stitch pleats.

Sew excellent blog has a fascinating method of making smocked polka dots. This method makes smocking stitch on the rear to keep the pleats set up and after uses smocking lines to make little polka spots on the front side of the fabric. It is worth attempt after the basic stitches are learned.

8.3.6 Shirring and Gauging

In sewing, shirring is at least two columns of accumulates, used to adorn portions of garments, often the sleeves, bodice or yoke. Shirring also used for decorative finish. The term is additionally some of the time used to refer to the pleats found in stage blinds. Shirring is a technique for moulding a garment and is done as such by controlling fullness. Its strategy is like social occasion. Shirring comprises of at least two lines of accumulated texture. Shirring can be a pretty option in contrast to darts in little regions of an garments. Shirring should likewise be possible on enormous zones of a garment like all around the highest point of a full skirt. Shirring works best on delicate textures yet can also done on more grounded fabrics.

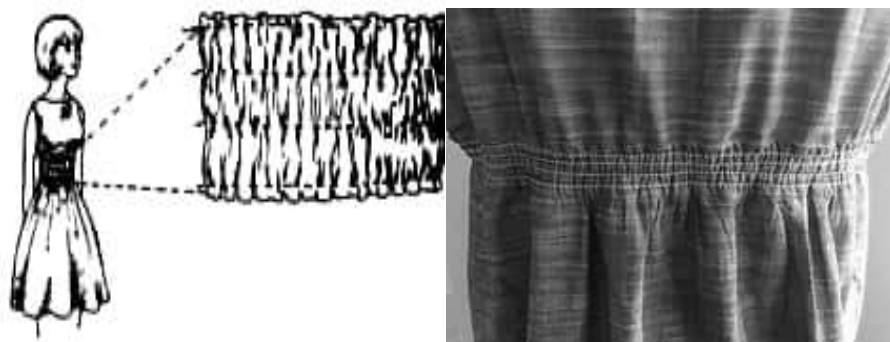

Shirring & Gauging (fig-29)

8.3.7 Godets

A godet is an additional piece of fabric in the shape of a round area which is set into garment, ordinarily a dress or skirt. These are wedge shaped pieces which are usually set in to a skirt so that the wide side of the wedge becomes a part of the hem of the skirt. Adding a godet to a piece of fabric gives the wearer a more extensive scope of movement.



Godet (fig-30)

8.3.8 Flare

Flare is brought generally into skirts, for including fullness and decoration at the hemline. To bring flare into a skirt, cuts are made beginning from the hemline to the required heights. These pieces must to be routinely separated around sew and drafted on another sheet of paper making flare.

Check Your Progress II

4. What is godet?

5. Enlist types of pleats and write its importance

6. Describe best fabric for smocking

7. Which stitches are used in smocking?

Multiple Choice Questions

1. Which technique of fullness is given below?

- A) Laces
- B) Collar
- C) Tucks
- D) Ruffles

2. Which is the Diamond darts?

- A) French
- B) Plain
- C) Double pointed
- D) All

3. Godet used in_____.

- A) Blouse
- B) Upper garments
- C) Skirts with flare
- D) Lower garments

4. Types of tucks

- A) Blind
- B) Corded
- C) None
- D) A and B both

5. Flare is mostly used in_____.

- A) Skirts
- B) Saree

C) Ladies t shirt

D) Romper

8.5 Let Us Sum Up

Fullness is presented into garments for different reasons, for example, to give great shape and good fit to the garments; and fullness is also used to decorative technique in garments to enable opportunity of development and solace to the wearer and to make the garments look beautiful. Darts, tucks, pleats, gathers etc. some of the methods for presenting fullness.

8.6 Key Words

Solace- comfort support

Utilized- used

Consistently- regularly, continuously

Moulding- shapes

Enormous- large, vast, huge

Transversely- crosswise

Segment- section

Beneath- below

Rear- back side

Consolidated- combined

Ample- sufficient, enough

8.7 Suggested Books

1. <https://sewguide.com>
2. <https://www.mybluprint.com>
3. Reader's Digest "Complete Guide to Sewing"
4. Singh, A & Bhardwaj, k (2012 "Textbook of clothing", vista international publishing house, Delhi) First Edition
5. Patel, V (2016 "Sewing technology", Sunrise Publication Co., Rajkot)
6. Dhruv publisher (2016-2017" Sewing Technology and Dress Making" Ahmedabad) First Edition

Answers

Check your progress I

1. Different Types of tucks

Tucks are for the most part utilized for decorative purposes and are an incredible method to include design any garments. Tucks are made by straight sewing an overlay of fabric. Consider them pleats whose folds really get sewed together. When sewn they are pressed and stay-sewed horizontally in a specific way according to the design.

Probably the most common tucks are pin tucks, dart tucks, blind tucks and space tucks. These tucks are exceptionally basic and come in various widths and alignments. Since a tuck is represented by a single fold, the width of the tucks is measuring the good ways from the overlay to the sewed line. The tuck's overlap can be found either within or outside of the garments.

Before we begin on the sewing steps, you must understand of tucks: Tucks are only an overlap of the fabric sewed by running stitch or machine stitch on the correct side of the garment. The purpose of tucks to shape the clothes to suit to the body, to hold fullness and to add a decorative touch to the garment. They can be sewed in groups, independently or in graduated width. The following are some different types of tucks.

- Blind tucks
- Pin tucks
- Spaced tucks
- Corded tucks
- Cross tucks
- Shell tucks
- Released or dart tucks
- Twisted tucks

2. Four method of gathering

1. Gathering by hand

Two rows of running stitch $\frac{1}{4}$ inch separated - $\frac{1}{8}$ inch is made. The closures of threads are drawn until the segment measures the ideal length. The thread is verified by twisting cycle a pin as shown.

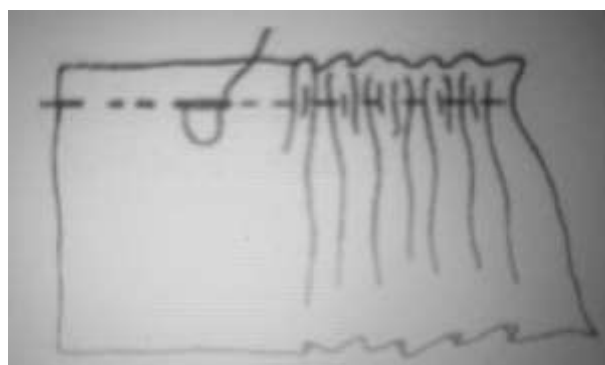

2. Gathering by machine

Make seam line on the correct side of the texture by changing the machine for long stitch and extricating the upper tension slightly. Make a few columns of little join on either side of the seam line on the area to be gathered

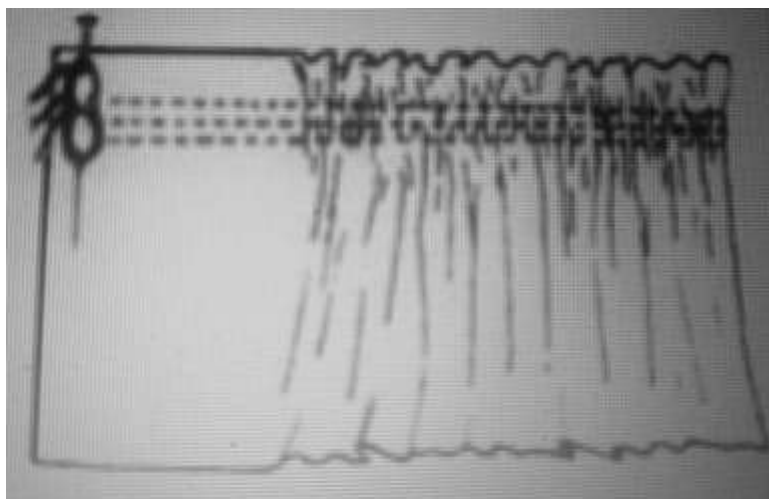

3. Gathering by elastic

Gathers can be made by stretching a narrow piece of elastic and sewing with attach to the piece of fabric which is to be gathered.

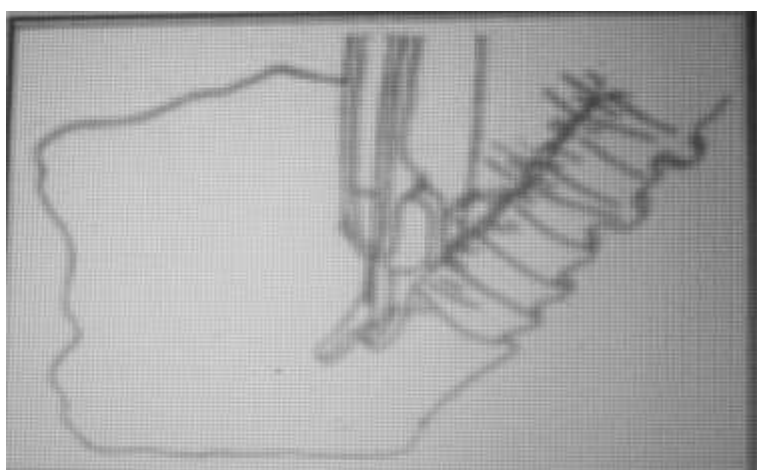

4. Automatic gathering

Automatic gathering is performed while sewing rather than organizing the fabric afterwards. It requires the utilization of either a gathering foot or a more complicated ruffle. Both lock and additional piece of fabric into the stitches as sewing is done.

3. Different types of darts

- Single darts/plain darts
- Double pointed darts/ contour darts
- French darts/ bust darts
- Skirt/pants darts

Check your progress II

4. Godet is an additional piece of fabric in the shape of a round area which is set into garment, ordinarily a dress or skirt. The option of a godet makes the piece of attire being referred to flare, in this way including width and volume. Adding a godet to a piece of fabric gives the wearer a more extensive scope of movement.
5. Types of pleats
 - Side (knife) pleats
 - Box pleats
 - Inverted pleats
 - Accordion pleats
 - Pleats with separate underlay
 - Kick pleats

Pleats are presented usually at the waistline of skirts and dresses, to provide fullness equally all around. The preparation of pleats is like that of tucks, the main difference being that pleats are only from time to time sewed right down. Each pleat requires additional material of double the width of the completed pleats. If pleats are to contact each other all round the garment, the measure of material required is multiple times the completed width.

6. Crap, silk, linen, cotton, gingham, velvet, chiffon, ribbon, weaves. You name the texture and it has been smocked by ladies in before times. A light to medium weight woven fabric with a smooth surface is perfect for smocking. You can select plain or printed cotton, poplin, cotton, silk, glossy silk, cotton blends, organdie, lightweight denim and lightweight wool.
7. Stitches used in smocking
 - Cable stitch
 - Wave stitch
 - Chevron
 - Outline stitch
 - Honeycomb stitch

Multiple Choice Questions

1. (C) 2. (C) 3. (C) 4. (D) 5. (A)

UNIT 9 NECKLINE FINISHING

9.0 Objectives

9.1 Introduction

9.2 Different Types of Necklines

9.3 Preventing of Gapping

9.4 Size of Neckline

9.5 Neckline Finishing

9.5.1 Preparation and Use of Bias Strip

9.5.1.1 Cutting Bias Strips

9.5.1.2 Joining Bias Strips

9.5.1.3 Use of Bias Strips

9.5.2 Different Methods of Finishing Neckline

9.5.2.1 Facing

9.5.2.1 Bias Binding

Check Your Progress

Multiple Choice Questions

9.6 Let Us Sum Up

9.7 Key Words

9.8 Suggested Books

Answers

9.0 Objectives

- In this Unit, You will able to know students knowing various types of neckline shapes.
- Different styles of neckline finishing
- How to apply the bias strips in neckline finishes.

9.1 Introduction

Neckline is a border of bodice around the neck area. Neckline can be done either by utilizing facing or binding or by attaching collar. The neck areas can be shaped in various style and styles to get a decorative impact,

especially for women clothing. Round, Square, V-neckline, U-neckline and so on are the most normally utilized states of neck area. A straight piece of material connected to complete these curved necklines will look massive and messy. The flexibility of bias permits it to stretch making a smooth finish. The different neckline finish includes fitted facing, bias facing and bias binding.

Necklines are maybe the most prominent part of any dress design which requires careful consideration thought, both while picking a design just as while sewing. Select a suitable and comfortable neck style and one fit to the texture. The neckline can be of different shape and sizes.

9.2 Different types of Necklines

Neckline is a part of bodice, around the neck. In women clothing, neckline can be shaped in various ways and styles to get an embellishing impact.

Round neckline:

Round neckline is more extensive in actuality than a 'V' shaped neckline, it is usually cut somewhat higher, its depth on the pattern being determined as suggested for the 'V' neckline when the depth has been noted, draw a line from the shoulder to this point, having the line extend downward with a slight slant for around 2/3 of the neckline depth and then curve a abruptly towards the middle front.



Round neckline (fig-1)

Square neckline:

This neckline shape takes after the square shape and has 4 corners, two in front and two at the back. This is utilized for dress, Tops and different women garment.



Square neckline (fig-2)

‘V’ shaped neckline:

It is shaped in front to a sharp point like the letter 'V'. On the middle front of the example, mark a point for the depth wanted and attracts a line to this point from the neck part of the shoulder line.



‘V’ neckline (fig-3)

‘U’ shaped neckline:

It is cut in the shape of letter 'U'. It is the adjustment of round neckline. The Depth of neckline is more than the simple round neckline.



‘U’ neckline (fig-4)

Halter neckline:

It consists of a strap, rope, or band around neck. And joined to backless bodice. It is tied in a bow at back neck. It is generally utilized in children’s party wear and dresses.



Halter neckline (fig-5)

Keyhole neckline:

It is a high round neckline with inverted wedge-shaped opening at front. These necklines look great when it is done with fitted facing. The depth of round neckline and inverted wedge can be changed.



Keyhole neckline (fig-6)

Scoop neckline:

It is a low curved neckline. It is cut somewhere down in front or back or both. The shape of the neckline, pretty much looks like the shape of pot and henceforth is additionally called as pot neck



Scoop neckline (fig-7)

Heart shaped neckline:

It is a deeply cut neckline with its front lower edge in heart shaped curve. It is the variety of square neckline.



Heart shape neckline (fig-8)

Wedge-shaped Neckline:

This is another variety of neckline where a straight line and curved line is combined to form a wedge-shaped opening. Mark points to indicate the depth needed and the width at lower line, which is wider than the regular square opening, join these points by a straight line, and then draw the side-line in the curved effect joining the straight line.



Wedge shape neckline (fig-9)

Cowl neckline:

A cowl neckline is created by adding at least one fold to the neckline. cowls are constantly cut on the bias and have free and folded effect when worn garment suitable for cowls are sheer and light weight type fabric, for example, chiffon, silk, crepe, crepe silk, delicate silk, georgette, satin, jersey etc. The Pattern prepared for specific fabric, satin, can't be utilized for chiffon, as every fabric is having various qualities.



Cowl neckline (fig-10)

Draw string neckline:

It is a neckline with cord, thread through a casing (folded edge with hole to insert Tape) to be gathered and balanced high or low. These are the parts utilized in Kid's wear like, Jabhla, Nighty and in women skirt top.



Draw string neckline (fig-11)

Boat neckline:

It is a boat shaped neckline, around following curve of the collarbone, high in front and back, wide at sides, and ending in or at shoulder seams. Its front neck depth is by and large kept more than the other neck depths.



Boat neckline (12)

9.3 Preventing of gapping

More profound necklines might be utilized for party and evening wear. If they are low, precautionary measures should be taken to keep them from gaping.

If a low curved neckline is utilized on the garment, this may should be tightened. To do this, cut the basic pattern from neck point to close to waistline and cover or connect a placket to the clothes.

9.4 Size of Neckline

The size of the neckline changes from person to person and pattern to pattern. The size of a neckline (for example the width and profundity) of a neckline is to be fixed before drafting diagram. For a neckline, neck with and neck depth are required as explained underneath.

0-2= Front and back neck width

0-1 = Front neck depth

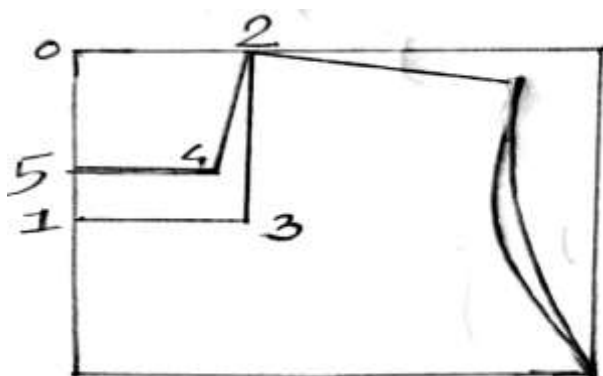

1-3-2 = Front neckline

0-5 = Back neck depth

5-4-2 = Back neckline

(fig-13)

9.5 Neckline finishing

Neck Proportions for ladies garments:

Neckline proportion women	for girls	for
1. Front or back neck width chest+1½”	1/12th chest	1/12the
2. Front neck depth chest +2”	1/12th chest+1/2”	1/8
3. Back neck depth	2”-2½”	2”-5”

9.5.1 Preparation and use of Bias Strip

Necklines, armholes and other curved parts of the garments require special treatment. It is better to use a bias strips than the strip cut on true grain to finish these opening.

Bias strips are commonly used to complete the neckline, because of its stretch capacity. Necklines are generally curved and hence tend to stretch during handling. A stretched neckline can spoil the presence clothing.

Most necklines are done in one of three different ways with facings, binding or with a collar. Regardless of the type a well-made neck finish should fit in with these standards

1. Neck edges must not be stretched up of shape.
2. All seams and edges must be as thin and smooth as they can be made, without weakening the clothing.
3. All edges must have great shape with precise corners and curves.
4. Facing edges, regardless of whether underneath a neckline or collar, must be hidden from view.
5. Body and stiffness of collar must be enough for the design. Bias strips which is generally called as cross piece or falls on a corner to corner line at 45° to the long way and crosswise grains. It has the most elasticity or in other word it stretches more than some other direction on fabric. True bias utilized to complete finish raw edges. It is valuable especially for completing curved edges, such as neckline, sleeveless armholes and scallops. A straight piece of material connected to a curve will look massive and untidy. The flexibility of bias permits it to stretch or contract and, in this way, takes the state of any curved edge giving it a flat smooth finish. Bias strips can be connected as facings and binding.

9.5.1.1 Cutting Bias Strips

Fold the fabric diagonally so the long way threads of the folded part fall parallel to the crosswise threads on the rest of the material. (If the grain lines can't be clearly observed, mark the lines with chalk first). Utilizing a gauge or ruler, measure from the overlay to wanted width of bias strip (generally 1 to 1½") and draw parallel lines. Cut strips along the marked lines and trim off finishes along the warp strings.

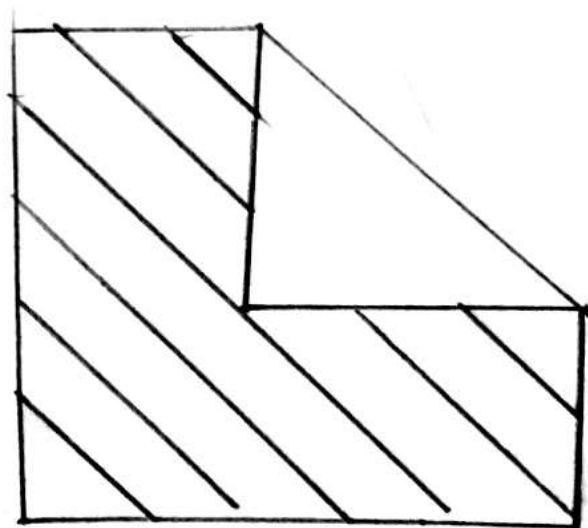

Cutting bias strip (fig-14)

9.5.1.2 Joining Bias Strips

Place the two strips to be joined right sides facing and the edges of the correct points to one another. Move the top strip ¼ inch past the other so that the sharp point at the ends of the strips project on either side. Stitch a ¼ inch seam to joining the points where the sides of the two strips cross. Press the seam open and trim the seam projections appearing on right side.

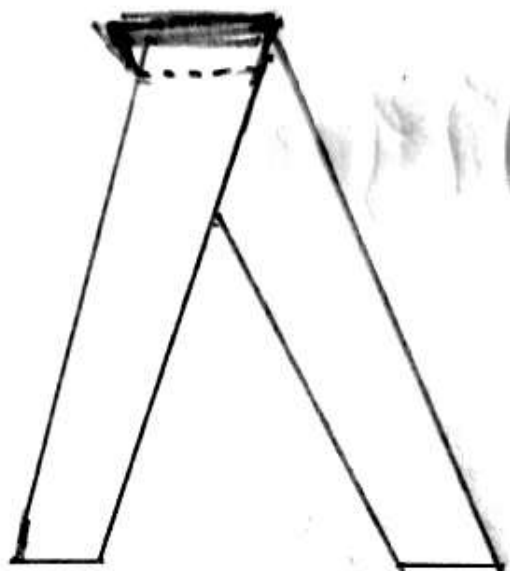

Joining bias strips (fig-15)

9.5.1.3 Use of Bias Strips

True bias is utilized to complete raw edges. It is valuable particularly in completing curved edges, for example, necklines, sleeveless armholes and scallops. The elasticity of bias permits it to stretch or contract and along takes the shapes of any curved edge giving it a flat smooth finish.

Bias strips can be connected as facing and binding. It can be in striped, checked or different shaded material. It gives a beautiful decorative finish when utilized as a binding or facing connected on the correct side of the clothing.

Bias is also used to complete raw edges of plain seams as well as seams which join collar neckline to, cuff to sleeves etc.

Fabric or bound buttonholes, piped seams and bias tubing are made utilizing bias strips. Bias tubing is helpful for making little motifs for cutting dresses and for getting ready fabric loops which can be utilized gorgeously in the place of buttonholes.

9.5.2 Different methods of finishing neckline

Neckline might be done with a facing, binding or a collar. The type of finish chosen will depend upon the design of clothing, the fabric and in some case even with personal preference. Necklines are commonly curved and subsequently will in general stretch during handling. It is therefore important to note of that before clothing development, a line of stay sewing is done a good way of 0.5 cm from the edge of the neckline, with the goal that it won't extend.

9.5.2.1 Facing

These are utilized to give a neat finish to the raw edges in a clothing and to help the state of necklines, armholes, collars, etc. At the point when the edge to be faced is a straight line, the facing might be cut in one piece with the garment segment. Normally facings are connected independently. There are two fundamental kinds of connected facings - shaped facing and bias facing.

Method of applying bias facing:

Cut a bias strip of true bias the width of which is equivalent to be done width and 2 turnings. Attach bias strip to edge of clothing, right sides facing starting at a seam. For internal corners to be faced the bias must be facilitated and for outward curves it must be stretched. (Easing means holding bias strip slightly free at the seam line). Stitch bias to the edge of the clothing in line with the bias on top. Trim the seam to ¼ inch, cut at curves, grade bulky seams and finishes matching. Turn the strip to wrong side underline the looking to the seam. Ensuring that the facing isn't noticeable from the correct side of the clothing. Presently fix or slip stitch

the looking to the garment. Whenever completed, the bias facing should be around 3/8-inch-wide.



Applying bias facing (fig-16)

Applying shaped or fitted facing:

Shaped facing is slash to the exact shape of the garment edge to which it is to be connected. Normally it is cut on a similar grain as the area of clothing. Shaped facing is frequently used to complete square or 'V' necklines or scalloped edges. It is simple to apply Extra bias facing and is less obvious. It is generally cut independently for front and back with allowances extra. Subsequent to cutting, join the front and back facings with a plain seam, trim the seam and press it open. Finish the external edge of the facing by turning up the edge and sewing it. Carefully attach the facing to the clothing segment, right sides facing, and seam lines, centre lines and notches matching. Trim, clips and grade seam edges turn the facing to the wrong side under stitch it at the seam and sew or slip stitch the folded edge of the facing to the garment. At the point when fitted facing is connected to right side of th clothing then it is called as beautiful facing.

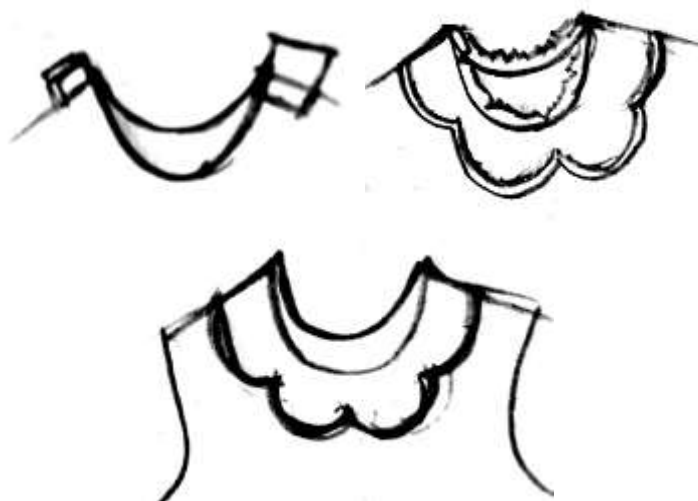

Applying decorative bias facing (fig-17)

9.5.2.1 Bias binding

True bias has the maximum elasticity or in other word it stretches more than some other direction on fabric. True bias is utilized to complete raw edges. It is valuable particularly for completing curved edges, for example, neckline, sleeveless armholes and scallops. A straight piece of material joined to a curve will look massive and untidy. The flexibility of bias permits it to stretch or contract and thus takes the shape of any curved edge giving it a flat smooth finish. Bias strips can be applied as facings and binding.

Bias binding is utilized to complete and strengthen raw edges and to add a beautifying trim to a garment. It shows both on the good and bad sides. It is utilized to complete necklines, armholes, sleeve edges, front closings, collars, cuffs and seams. It can be adjusted similarly well to straight, curved, gathered and irregular edges. Whenever completed, bias binding should have uniform width (not exactly $\frac{1}{4}$ inch) and should lie flat and smooth with no stitches showing on the correct side of the clothing.

There are two kind of bias binding 1) Single binding 2) double binding or French binding

1) Single bias binding

Cut a bias strip that is twice the completed width in addition to two seam allowances. Attach the strip to the garment right sides facing. Stitch the binding to the garment with a plain seam. Trim the seam as wide as the completed the process of binding. Turn under $\frac{1}{8}$ to $\frac{1}{4}$ inch on the external edge of the bias and fold it over the seam on the wrong side. Presently sew the overlap to the line of sewing utilizing hemming stitches.

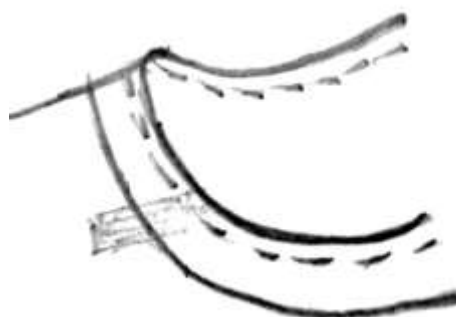

Single bias facing (fig-18)

2) Double or French binding

French binding or double bias binding is utilized on sheer fabrics. Cut bias strip that is multiple times the desired completed width. Fold the strip down the middle, wrong sides together, and press. Stitch raw edges of the garment on the correct side and hem the folded edge to sewing line on the wrong side.

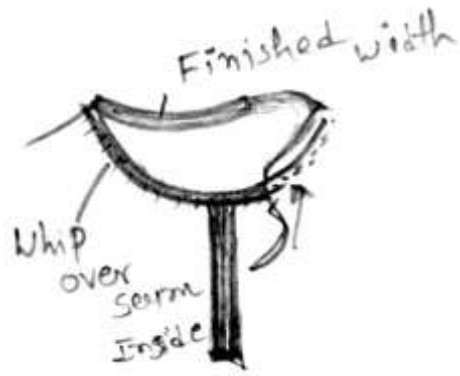

Double bias facing (fig-19)

Check Your Progress

1. Name different types of necklines.

2. How will you prevent gapping of neckline?

3. What is bias piece? Write its usage.

4. What is binding? Mention the types of binding.

5. How are the bias strips attached?

6. What is facing?

Multiple Choice Questions

1. Which is the part of bodice pattern that is around the neck?
 - (a) Sleeve
 - (b) Neckline
 - (c) Skirts
 - (d) Cuffs
2. Which necklines consist of a strap, rope or band around neck, attached to backless bodice?
 - (a) Halter neckline
 - (b) Scoop neckline
 - (c) 'U'-shaped neckline
 - (d) 'V' shaped neckline
3. This type of neckline is used in Jabhla with cord,
 - (a) Boat neckline
 - (b) Square neckline
 - (c) Draw string neckline
 - (d) Scoop neckline
4. How necklines are mostly finished?
 - (a) with facing
 - (b) with binding
 - (c) with collar
 - (d) all the three
5. A fabric which falls on a diagonal line at 45° to the lengthwise and cross wise grain is called,
 - (a) Bias piece
 - (b) Straight piece
 - (c) diagonal piece
 - (d) none of the above
6. Which will be the measurement of front neck depth for a girls garment?
 - (a) $\frac{1}{12}$ th chest
 - (b) $\frac{1}{12}$ chest + $\frac{1}{2}$ "
 - (c) $\frac{1}{8}$ chest + 2"
 - (d) 2-2 $\frac{1}{2}$ "

9.6 Let Us Sum Up

As neckline is the outer finishing of bodice around the neck, it can be shaped and completed in various ways for strengthening just as for decorative reason. Any of the methods described can be chosen to complete the necklines according to the need of the garment and design of the period. Bias binding and decorative facings are seen on the correct side of the

clothing, bias facings are commonly completed on the wrong side of the garment. Care is to be taken while completing the necklines, particularly curved ones. Continuously stay stitch around the neckline before completing it, as this will avoid shaping out of the neckline.

9.7 Key Words

Descending-downward

Abruptly-shortly

Profound-deep

Enormously- extremely

Sturdy-durable

9.8 Suggested Books

- Reader's Digest "Complete Guide to Sewing"
- <https://en.wikipedia.org/wiki/Neckline>
- https://www.brainkart.com/article/Neckline-and-Collars_35628/

Answers

Check Your Progress

1. Different types of neckline
1) Heart shaped neckline 2) 'U' shape neckline 3) 'v' shape neckline
4) round neckline 5) boat neck 6) scoop neckline 7) keyhole
neckline 8) halter neckline 9) square neckline 10) cowl neckline 11)
draw string neckline 12) wedge shape neckline
2. Preventing gapping making with the cut of basic pattern from neck
point to close to waistline and cover or connect a placket to the
clothes.
3. Bias strips are commonly used to complete the neckline,
considering its stretch capacity. Necklines are generally curved and
hence tend to stretch during handling. A stretched neckline can spoil
the presence clothing. So incredible consideration must be taken in
handling care of and completing neckline.
Most necklines are done in one of three different ways with facings,
binding or with a collar. Regardless of the type a well-made neck
finish should fit in with these standards
 1. Neck edges must not be stretched up of shape.
 2. All seams and edges must be as thin and smooth as they can be
made, without weakening the clothing.
 3. All edges must have great shape with precise corners and curves.
 4. facing edges, regardless of whether underneath a neckline or
collar, must be hidden from view.
 5. Body and stiffness of collar must be enough for the design. Bias
strips which is generally called as cross piece or falls on a corner to

corner line at 45° to the long way and crosswise grains. It has the most elasticity or in other word it stretches more than some other direction on fabric. True bias utilized to complete finish raw edges. It is valuable especially for completing curved edges, such as neckline, sleeveless armholes and scallops. A straight piece of material connected to a curve will look massive and untidy. The flexibility of bias permits it to stretch or contract and, in this way, takes the state of any curved edge giving it a flat smooth finish. Bias strips can be connected as facings and binding.

4. Bias binding is utilized to complete and strengthen raw edges and to add a beautifying trim to a garment. It shows both on the good and bad sides. It is utilized to complete necklines, armholes, sleeve edges, front closings, collars, cuffs and seams. It can be adjusted similarly well to straight, curved, gathered and irregular edges. Whenever completed, bias binding should have uniform width and should lie flat and smooth with no stitches showing on the correct side of the clothing.

There are two kind of bias binding 1) Single binding 2) double binding or French binding

5.
 - Cut a bias strip of genuine bias the width of which is equivalent to be done width and 2 turnings.
 - Attach bias strip to edge of clothing, right sides facing starting at a seam.
 - For internal corners to be faced the bias must be facilitated and for outward curves it must be stretched.
 - Stitch bias to the edge of the clothing in line with the bias on top.
 - Trim the seam to ¼ inch, cut at curves, grade bulky seams and finishes matching.
 - Turn the strip to wrong side underline the looking to the seam.
 - Ensuring that the facing isn't noticeable from the correct side of the clothing. Presently fix or slip stitch the looking to the garment.
6. Facing are utilized to give a neat finish to the raw edges in a clothing and to help the state of necklines, armholes, collars And makes attract to of garments.

Multiple Choice Questions

1. (b) 2. (a) 3. (c) 4 (d) 5. (a) 6. (b)

UNIT 10 POCKETS AND YOKE

10.0 Objectives

10.1 Introduction

10.2 Different Types of Pockets

10.2.1 Patch Pockets

10.2.2 In Seam Pockets

10.2.3 Slash Pockets

10.3 Selection of Pocket Design

10.4 Creating Variety in Pocket Design

Check Your Progress I

10.5 Introduction to Yokes

10.6 Selection of Yoke Design

10.7 Creating Variety in Yoke Design

10.8 Preparing Pattern of Different Types of Yokes

Check Your Progress II

Multiple Choice Questions

10.9 Let Us Sum Up

10.10 Key Words

10.11 Suggested Books

Answers

10.0 Objectives

- In this Unit, You will be able to get knowledge regarding types of pockets and yokes.
- To understand use of pockets and yokes in pattern making of apparel.
- To understand how to finish yoke and pockets.

10.1 Introduction

Pockets are commonly used mostly for utilitarian reason instead of for decoration. The main reason for pockets in ladies' dress is to include

configuration interest. It should be arranged giving extensive attention regarding the plan of the dress and figure of the wearer.

Appearance of the children's clothing can be improved, by designing pockets of varied shapes, sizes and area with decorative details, for example, bias binding, laces, ruffles, tucks, pleats, applique, embroidery etc.

In men's and young men's garments, pockets are utilized to keep the things. The main motivation behind pockets in ladies' apparel is to add design interest. They should be arranged in giving significant attention for the design of the dress and the figure of the wearer. Kids love to have pockets in their dresses. Appearance of kids ' clothing can be improved, as it were, by planning pocket with various shapes, sizes, and areas with embellishing details.

A yoke is a part of clothing typically set at the shoulders, over the waistline-at midsection or beneath the waistline-at hip.

10.2 Different types of Pockets

There are three main types of pockets

10.2.1 Patch pockets

These are attached to the outside of the garment and might be cut in different shapes. A pocket might be furnished with a flap which holds it shut or a flap might be given by cutting the highest point of the pocket with a shaped band that look like a working flap. Now and then flaps are utilized with no pocket, only for design. It is additionally the most common kind of pockets. You might be seen patch pockets on shirt fronts. It is available various shapes like square, rectangular, round and even triangular.

Patch pocket might be lined or unlined. A lining is required for textures that stretch or sag. Textures that are firm enough to hold their shape can be utilized without a lining. The steps in constructing a patch pocket are as per the following.

Sometimes patch pocket is sewed with a pleat in the front. The pleat is normally a crate box or inverted box pleat. This crease is given so you get more space inside. They are then called the Bellows/Safari Pockets - outside pockets made with middle box pleat or inverted pleat that expand when pocket is utilized.

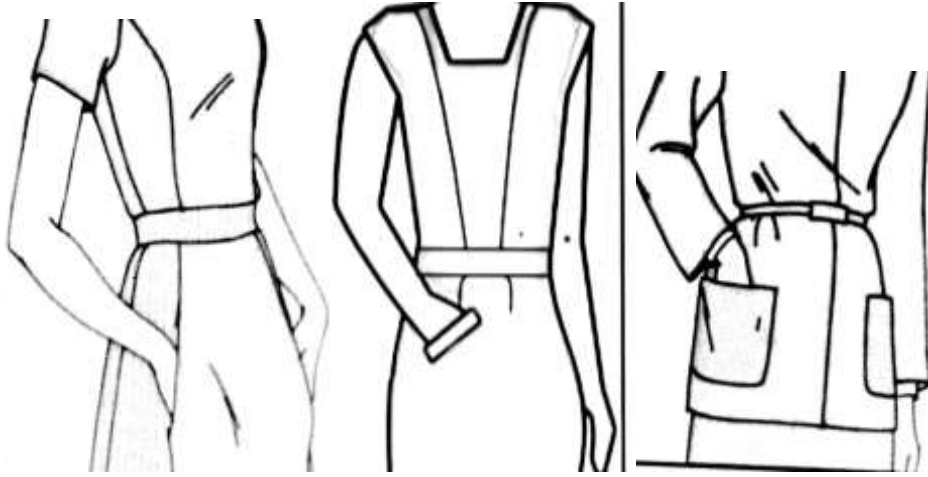

In seam pocket (fig-1) Slash pocket (fig-2) Patch pocket (fig-3)

Construction of Patch Pocket

1. Turn under top raw edge of pocket facing and edge stitch. $\frac{1}{4}$ " (6mm), press and stitch.
2. Fold facing to the right side of the pocket along fold line and stitch on seam line.
3. Stay stitch around the pocket on the seam line, starting at overlap line of the facing. The stay join will go about as a guide for turning and pressing the edges and corners.
4. Trim and grade sew seam allowances. Clip upper corners. Turn hem right side out and press.
5. Overlay in seam allowances along sewing and press. Square corners must be mitred; adjusted corners must be notched.
6. Join the edge of sews to the pocket by hand, or top stitch from right side.
7. Stick the pocket to the garment. Slip stitch around the pocket by hand. Or on the other hand top stitch edges set up. Reinforce corners by back stitching or by sewing a little triangle or square.

Both the top corners of the pockets must be reinforced properly to add strength. This can be done by the following methods.

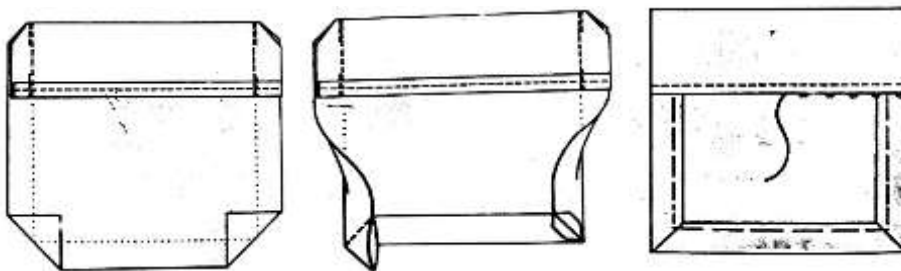

Construction of patch pocket (fig-4)

Corner reinforcement of patch pocket:

- 1. Little, identical triangles sewed at each top corner:** This is the pocket reinforcement seen most as often as possible on shirts.
- 2. A zigzag stitch:** This stitch about $\frac{1}{8}$ " wide and closely spaced, keeps running down $\frac{1}{2}$ " from the highest point of each side. This stitch is useful for kid's garment.
- 3. A backstitch:** This is utilized for $\frac{1}{2}$ " on each side of the pocket's opening edge, with thread closes tied. This method is frequently utilized on child's wear.
- 4. Patched texture:** A patch texture or fusible interlining, set on the wrong side of garment under support sewing, includes quality.
- 5. Hand reinforcement:** Hand reinforcement is finished with Whip Stitch, imperceptibly for $\frac{1}{4}$ " on each side of top corners.
- 6. Bar-tacking:** Another hand method in bar tacking $\frac{1}{4}$ " long straight stitches slanting corners with blanket stitches worked over them.

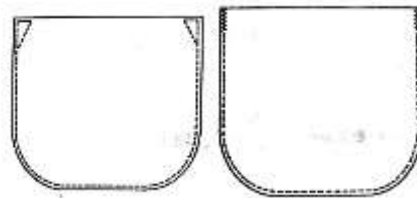

Identical triangular stitch Zigzag stitch

(Fig 5-6)

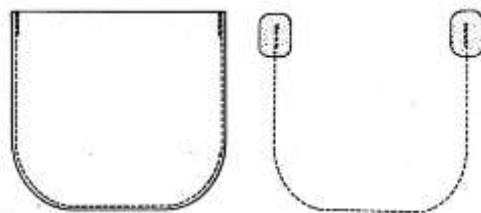

Back stitch Patched fabric

(Fig7-8)

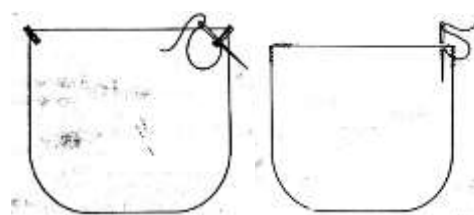

Hand reinforcement Bar tacking

(Fig 9-10)

10.2.2 In seam pockets

This is the easiest kind of pocket to make. The pocket is joined to the side seam of the garment. It can be cut as part of the garment front and back. Or it can be cut from a separate pattern piece and sewed to the seam. If the outer part of garment is bulky and heavy, then cut the pocket pieces from lining fabric.

Any kind of pocket wherein the opening falls along a seam line of the garment is referred as 'pocket set into seam'. This type of pocket is utilized in jeans of men and women skirts, pants, shorts, children's wear, kurtas and night wear.

Construction of in Seam Pocket

1. Stitch a piece of crease tape or twill tape along the front and back overlay line or seam line to prevent stretching.
2. If the pocket is cut independently, stitch pocket pieces to front and back opening, right sides together. Press seam allowances toward pocket pieces.
3. Stick the garment front to garment back, matching markings at seam line and pocket.
4. Stitch directionally along seam and around pocket in one stage. Use reinforcement join, 15 to 20 stitches per inch at the corners. Press seam allowances flat.
5. Turn the pocket toward the front of the garment. Clip back seam allowances above and underneath pocket so that the seam allowance of the garment can be pressed open. Piping material would be effective. Buttons might be fixed in groups to create design interest gradually progressing in size from little to big.
6. Seam can be done if necessary.

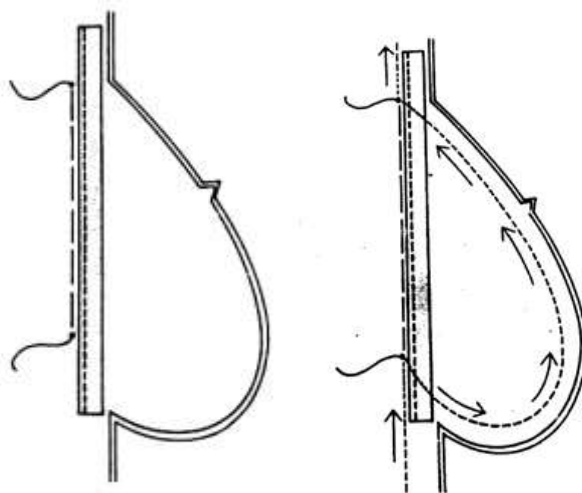

Construction of in seam pocket (fig-11)

10.2.3 Slash pockets

This kind of pocket is inside the garment with a cut of some kind for its opening. There are three kinds of cut pockets bound, welt and flap. In the bound pocket each edge of the slash is done with binding of even width pocket has one wide end called the welt extending above the pocket opening. The flap pocket has a flap of extension turned down over the opening. Cut pockets are identified by a cut or cut in the garment, and can be differently completed with a welt, flap, the pocket itself, or some combination of every one of the three.

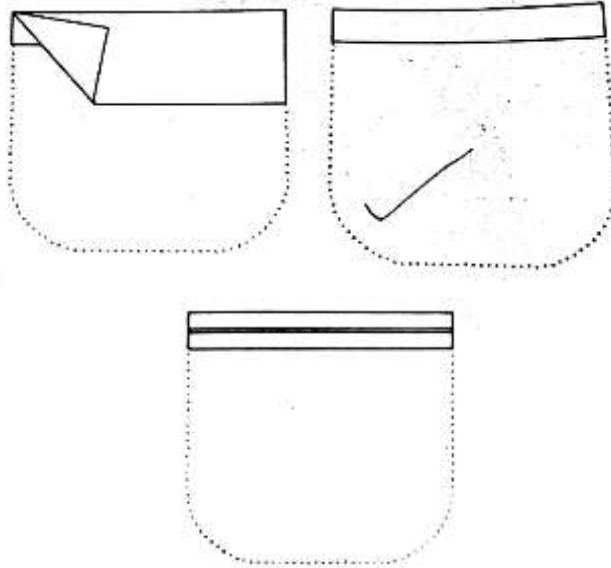

Flap (fig-12)

Welt (fig-13)

Bound (fig-14)

Construction of Slash pocket

In bound pocket the edges are cut and completed with binding. This is even in width.

1. Cut along line on the front garment design.
2. Cut texture pieces according to cut pocket.
3. Alter front piece of the piece of clothing according to the pocket slant.
4. Place the correct side of the pocket on the correct side of the garment.
5. Stitch along a seam line and press seam allowance.
6. Fold pocket facing a wrong side, complete the base trim line with a row of sewing.
7. Flip the pocket back to bring the correct side of the pocket out.
8. Stitch pocket to front board of the garment.
9. Press perfectly.

10.3 Selection of pocket design

Pocket design ought to harmonize with the design of the texture just as the design of the garment and its segments (collar, sleeve, and etc) For the

striped dress the rectangular shaped pockets cut on crosswise grain and completed with bias edging is a decent choice. The scalloped pocket in look getting to be on the grounds that they harmony with the scalloped collar and heart shaped pocket of the dress.

Pocket design should be fitting for the types of the garment and the purpose and utilization of the garment. Basic straight-line pockets are generally used for school outfits and casual wear garments, while conspicuous pocket styles with designs and trimmings might be utilized on party wear dresses.

The sex and age just as the figure and personality of the wearer should be considered while designing pockets. Pick the pocket design that suit for kids' dresses. Scalloped and rounded pocket are ending up just for girls dresses. Straight line pockets are suitable for men's and boy's garments. For adult ladies and short ladies, inconspicuous designs such as set-in pocket is suitable. Ladies with a huge bust line should avoid design with breast pockets. The pocket design should be proper from the types of garment and the purpose and utilization of the garment. For example, straightforward straight-line pockets are suitable for school uniforms and casual wear garments, while conspicuous pocket styles with decoration trimmings (fit to the wearer) might be utilized on party wear dresses.

10.4 Creating Variety in pocket design

10.4.1 Variety in shape, size, location and number

Pockets can be of different shapes like rectangular, triangular, heart shapes, oval shapes, scalloped, round etc. They might be put at various positions in the garments. A pocket design can be with two front pockets and two hip pockets, the size of the hip pocket being about 1½ times more than the size of the front pockets. Pockets commonly used in pairs, but single pockets might be used.

10.4.2 Variety in material and grain

Interesting effect can be archived by arranging pockets of material different in design, colour, texture or grain from the garment material. A design with the pocket fold (likewise the neckline and catches) can be produced using different coloured material. A design with printed pockets on plain texture. A striped dress design where the pocket is cut on across grain and completed with bias edging while the rest of the garment is cut on the length wise grain.

10.4.3 Variety in decorative details and trimmings used on the pockets

The outer edge of the pocket might be done with ruffles, bias binding, lace, decorative stitches etc. decoration within pocket in the from tucks, pleats, applique, embroidery, patchwork etc.

Check your Progress I

1. Name the types of pocket.

2. Name the types of slash pocket.

3. Explain patch pocket.

4. How will you create variety by changing material and grain?

5. Write about different types of pocket.

10.5 Introduction to Yokes

Yoke is a part of an garment generally attach at the shoulder, over the waistline (at midsection) or beneath the waistline for controlling and supporting fullness required over the bust, chest, hips etc. yoke help to keep the upper part of the waistline of a garment trim and smooth. Yokes are sometimes designed only for decoration and might not have any fullness.

The construction of yoke design includes some "cutting up"- a significant element in designing. The front and back are separated or "cut up" in-to two segments: a "yoke" and "bottom par". The bottom part under the yoke, can

be simple fitting, tight or full, and can have gathers, tucks, smocking, gauging and various types of pleats, folds and even draping effects.



Hip yoke
Shoulder yoke

Midriff yoke

(Fig-15-16-17-18)

10.6 Selection of Yoke Design

The yoke design can be used on a garment will depend on different factors; the important factors are below with examples.

10.6.1 Design of the fabric

There should be harmony between the shape of the yoke and design of the texture. For material with enormous checks or stripes are not fitting for yoke with round or curved shapes. They are appropriate for straight line yokes, Floral designs or curved line texture will be more suitable for round or curved yoke.

10.6.2 Design of the garment

Design of the yoke should be harmonized with the design of the garment. Yoke can be designed, which repeats the shape of the design details of the dress. (For example, collar, sleeve, pockets etc.) but with slight varieties to avoid repetitiveness. To ease the mono of curved lines. Straight line tucks are sewed on the lower segment of the piece of clothing.

10.6.3 Purpose and use of the garment

Yoke is the best for school garbs and home wear clothes. Select straightforward yokes style. For party wear garbs, the yokes design can be in decorative shapes, for example, scalloped, lopsided etc. with different material and embellishing edging of ribbon laces and frills etc.

10.6.4 Sex and age of the wearer

Round and curved yokes are more suitable for young girls while straight yokes are should progressively fit to boys. Old ladies should choose straight forward yokes designs and avoid style which are too decorative.

10.6.5 Figure and personality of the wearer

Deep narrow yokes with vertical embellishments incorporate vertical eye movement giving an impression of included height and less width, in this way making an individual look taller and slimmer. Thus, select such yoke designs for a short full figure. Horizontal lines in yokes make a people look shorter and fatter and are suitable for slim figures. A yoke wide at the shoulder and pointed towards the waistline gives the impression of a narrow midriff and wide shoulder. A person with round face should avoid round yokes just as straight-line yokes because repetition and contrast both highlight the roundness.

10.7 Creating Variety in Yoke Design

10.7.1 Designing seam line of yoke:

The yoke can be joined to the body of the garment in a decorative might be insertion of ruffles, lace, faggoting, decorative stitches or top stitches in contrasting coloured thread.

10.7.2 Designing yokes which release fullness in various forms:

Fullness is released in the form of gathers, pleats and tucks from the edge of the yoke.

10.7.3 Introducing the yoke at different position:

The yoke might be presented at the highest point of the dress (shoulder yoke) over the midriff yoke beneath the waistline (hip yoke)

10.7.4 Decoration within the yoke:

The yokes can be beaded, quilted, embroidery, shirred, smocked, tucked, creased.

10.7.5 Variety in shape and size:

A yoke can be designed with different shapes, for example, square, round straight line, scalloped, triangular etc. Some time, some portion of a yoke may extend out to the full length of the garment. This kind of yoke is referred to as yoke with panel. Occasionally the yoke may extend into the sleeve, or it might expand just mostly over the garment as in a partial yoke. A yoke can be deep or shallow, broad or narrow according to the desire.



Yoke with panel (fig-19)



Partial yoke (fig-20)

10.7.6 Variety in material and grain:

If the clothing is of light shading, the yoke might be made of a different coloured texture for dark coloured clothing the yoke might be white or light shading. A yoke with prints is attached with the plain garment or the other way around would give a decent appearance. As to grain, a design in a plan where the yoke is cut on bias and the garment on the lengthwise grain.

10.8 Preparing Pattern of Different Types of Yokes

Yoke without fullness

This kind of yokes can be of assortment with various shapes and size. To set up the pattern for this, take the front bodice pattern and draw the yoke line from shoulder to centre front as wanted. For a curved or 'V' shaped yoke, this strategy must be followed, for a straight-line yoke, draw line from armhole to centre front of bodice design. Mark both the segment.



Yoke without fullness (fig-21)

Yoke with fullness:

This kind of yoke, decorate the fabric with (tucks crease, gathers, shirring and embroidery) any fullness must be done first put the yoke design over the decorated fabric. Cut the required amount of fabric and stitch tucks as according to the design. Keep the paper design on the tucked fabric and cut the right shape including seam allowance and attach it with different designs.

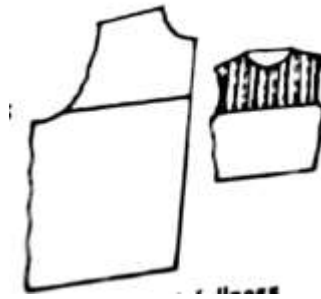

Yoke with fullness (fig-22)

Attaching yokes:

A yoke might be possibly appended to the lower area by either a plain seam or a lapped seam. Lapped seam cuffs the yoke and the skirt including crease allowances, on the texture. gather the skirt making that the width of the yoke and skirt are equivalent after the skirt has been gathered. Presently place the yoke over the skirt right side facing and matching notches.

Pin and tack distributing gathers equally. Machine on a wrong side of the yoke along the seam line as appeared. At last remove the tacking and turn up yoke on the correct side and press.

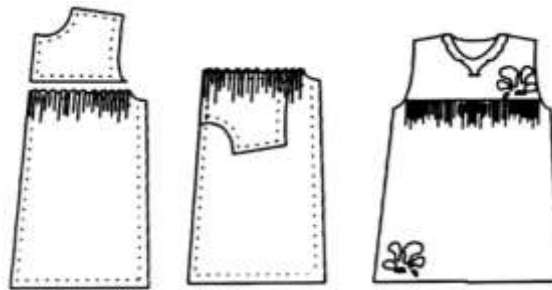

Straight-line yoke (fig-23)

Yoke which has curve and straight line as in skirt with panel the seam runs nearly at the correct edges to the corner. First, set up the lower segment of the garment by working the gathering stitch lines. Next take the yoke, and work machine stitch simply close the seam line and strengthen the corners, overlay the seam allowance to a wrong side and tack with little stitch near the overlap. To enable the seam to be flat, cuff notches into the crease allowance.

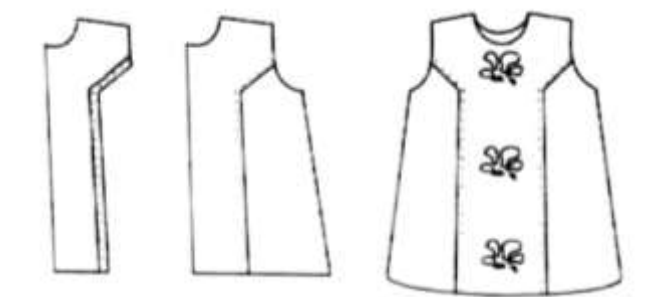

Decorative yoke (fig-24)

Next keep the yoke over the lower area, matching seam lines. Tack in position and top stitch. Close to the folded edge of the yokes. A tucked seam impact can be got, if desired, but doing the top stitching away from the folded edge of the yoke.

Check your progress II

6. Name three types of yoke.

7. Explain about attaching yokes with garment.

8. What is partial yoke?

9. What is panel yoke?

Multiple choice questions

1. How many types of slash pocket are there?

- (A) three
- (B) four
- (C) five
- (D) six

2. _____ will be more suitable for girls' dresses.

- (A) straight pocket
- (B) round pocket
- (C) both
- (D) none

3. Welt pocket belongs to this type,

- (A) patch pocket
- (B) bound pocket
- (C) in seam pocket
- (D) slash pocket

4. Which is attached for decoration without pocket?

- (A) flap
- (B) welt
- (C) pocket
- (D) patch pocket

5. _____ yoke will be more suitable for school uniforms

- (A) Yoke with shirring
- (B) Simple plain yoke
- (C) yoke with pin tuck
- (D) 'V' shaped yoke

6. Yoke which extend to the full length of the garment,

- (A) partial yoke
- (B) yoke with panel
- (C) Yoke with fullness
- (D) Yoke without fullness

7. Which style of yoke must be used in dresses of old women?

- (A) simple plain yoke
- (B) yoke with pin tuck
- (C) yoke with shirring
- (D) 'V' shaped yoke

8. To increase the height of wearer _____ yoke must be used,

- (A) Broad Deep yoke
- (B) Deep narrow yoke
- (C) Round yoke
- (D) Straight line yoke

10.9 Let Us Sum Up

The knowledge on pockets and yokes is very important for one who undergoes designing courses. A pocket is a bag- or envelope-like receptacle either fastened to or inserted in a garment to hold small items. A yoke enhances the beauty of the garments. Pockets are generally used mainly for utilitarian purpose rather than for decoration. The chief purpose of pockets in women's clothing is to add design interest. They

should be planned to give considerable attention to the design of the dress and figure of the wearer.

10.10 Key Words

Segments-parts, sections, portions

Harmony-coordination

Enormous-huge, large

Ease- comfort, relieve

Mono- simple

Garbs- outfits, clothes, costumes

Lopsided- uneven, unequal

Embellishments-decorations

Midriff- waist

Assortment- variety

10.11 Suggested books

<https://shop.mybluprint.com/sewing/article/kinds-of-pockets/>

https://www.brainkart.com/article/Types-of-Pockets_1840/

<https://clothingindustry.blogspot.com/2018/05/different-types-yokes-dresses.html>

Reader's Digest "Complete Guide to Sewing"

Answers

Check Your Progress I

1. There are main three types of pockets
 - I. Patch pocket
 - II. Inside seam pocket
 - III. Slash pocket
2. There are three kind of slash pocket
 - I. Welt pocket
 - II. Flap pocket
 - III. Bound pocket
3. Patch pockets are used on women, men and children garments. Patch pockets are attached to the outside of the garment and might be cut in different shapes. A pocket might be furnished with a flap which holds it shut of a flap might be given by cutting the highest point of the pocket with a shaped band that look like a working flap. Now and then flaps are utilized with no pocket, only for design it is additionally the most common kind of pockets. You might be seen patch pockets on shirt fronts. It is available various shapes like

square, rectangular, round and even triangular. Patch pocket might be lined or unlined. A lining is required for textures that stretch or sag. Textures that are firm enough to hold their shape can be utilized without a lining. The steps in constructing a patch pocket are as per the following. Patch pocket is sewed with a pleat in the front. The pleat is normally a crate box or inverted box pleat. This crease is given so you get more space inside. They are then called the Bellows/Safari Pockets - outside pockets made with middle box pleat or inverted pleat that expand when pocket is utilized.

4. In material effect can be archived by arranging pockets of material different in design, colour, texture or grain. A design with the pocket fold (likewise the neckline and buttons) can be produced using different coloured material. A design with printed pockets on plain clothing and the other way around. A striped dress design where the pocket is cut on across grain and completed with bias edging while the rest of the garment is cut on the lengthwise grain.
5. There are three types of pockets patch pockets attached to the outside of the garment in seam pockets are opening to seam line of the garment generally used to pant pockets and skirts. And the other is slash pockets its called cut pockets. These pockets are inside the garment with the slash. Pockets are used in garment for decoration purpose.

Check Your Progress II

6. In construction of clothing there are three types of yokes 1. **Yoke without fullness** 2. **Yoke with fullness** 3. **Attaching yokes**
7. Attaching yoke might be possibly appended to the lower area by either a plain seam or a lapped seam. Lapped seam cuffs the yoke and the skirt including crease allowances, on the texture. Gather the skirt making that the width of the yoke and skirt are equivalent after the skirt has been gathered. Presently place the yoke over the skirt right side facing and matching notches. Stick and tack distributing gathers equally. Machine on a wrong side of the yoke along the seam line as appeared. At last remove the tacking and turn up yoke on the correct side and press. Yoke which has curve and straight line as in skirt with panel the seam runs nearly at the correct edges to the corner. First, set up the lower segment of the garment by working the gathering stitch lines. Next take the yoke, and work machine stitch simply close the seam line and strengthen the corners, overlay the seam allowance to a wrong side and tack with little stitch near the overlap. To enable the seam to be flat, cuff notches into the crease allowance. Next keep the yoke over the lower area, matching seam lines. Tack in position and top stitch. Near the folded edge of the yokes. A tucked seam impact can be got, whenever wanted, by doing the top sewing away from the folded edge of the yoke.
8. A yoke, which does not extend across the entire garment, is called a partial yoke.

9. A panel yoke with designed with various shapes like straight line, scalloped, triangular etc. sometimes yoke extend to the length of garment.

Multiple Choice Questions

1(A) 2 (B) 3 (D) 4 (A) 5 (B) 6 (B) 7 (A) 8 (D)

UNIT 11 SLEEVES

11.0 Objectives

11.1 Introduction

11.2 Terminology of Sleeves

11.3 Basic Sleeve Style

11.3.1 Classic Sleeve

11.3.2 Casual Sleeve

11.3.3 T-Shirt Sleeve

11.4 Different Types of Sleeves

11.4.1 Set in Sleeve

11.4.2 Non Set in Sleeve

11.5 Standards of a Well Fitted Sleeves

Check Your Progress

Multiple Choice Questions

11.6 Let Us Sum Up

11.7 Key Words

11.8 Suggested Books

Answers

11.0 Objectives

- In this Unit, you will be able to gain knowledge of different types of sleeves
- Use of different types of sleeves in garments
- Type of sleeve in making pattern of the garments.

11.1 Introduction

Sleeves have been utilized as a device for changing the silhouette of garments all through fashion history. Sleeves are decorative parts of the garments that spread and enclose the arm. They have a major effect on silhouette, since they extend from an extraordinary expansive bore style to a characteristic rounded structure. Silhouette is affected by sleeve length and by the measure of fullness joined into the sleeve designs. Sleeves might be of any length, including cap, short, elbow, three-quarter, seven eighths

and long. Also, sleeves might be fitted or full and may incorporate a puff, bell, draped or gathered style. The fundamental sleeve is the creation for all sleeve varieties. Sleeve designs changes are made in connection to the accompanying reference points.

11.2 Terminology of Sleeves

1) **Cap Seam line:** This is the curved cap seam line of the sleeve. Notches are constantly utilized along this line for matching the sleeve to the bodice arm scye. Sleeve fit is influenced by the silhouette of this curved seam line. Indistinguishable inward curves along the lower bodice arm scye seams and the lower some portion of the cap seam line upgrade a smooth fit at the underarm parts.

2) **Cap line:** The even line that joins the two underarm corners. It is the most extensive piece of the essential sleeve and furthermore designates the bicep line and across grain.

3) **Sleeve cap:** The upper part of the sleeve between the cap seam line and the top line. This portion must be sufficiently high to cover the arm from the shoulder to the biceps without pulling up. Cap height might be expanded or diminished as style varieties are created. In any case, cap height ought not to be abbreviated for the basic sleeve.

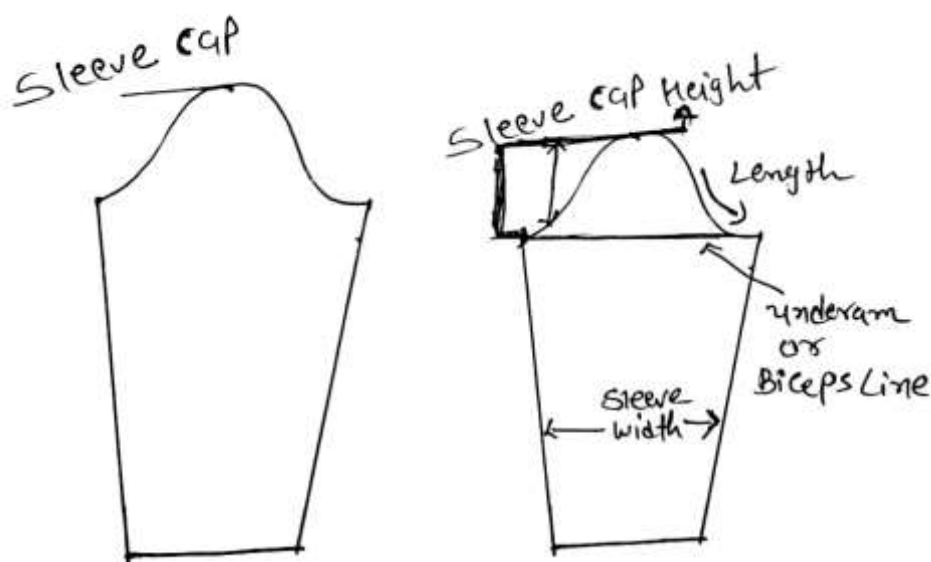

(Fig-1)

4) **Grain line:** A line that is vertical to the cap line and expands the length of the sleeve

5) **Underarm seams:** The two vertical seams that stretch out down from the cap line corners to the length of the sleeve. On the essential sleeve, the front underarm seam is a slight internal curve, while the back is a slight outward curve.

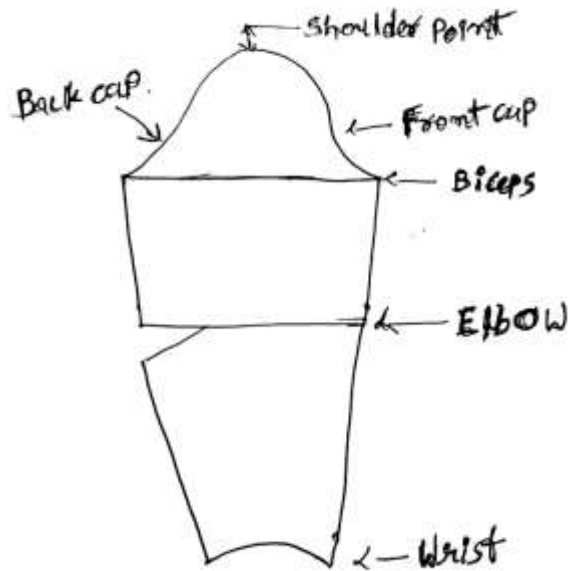

(fig-2)

6) Elbow Darts: That shapes the sleeve to fit the regular twist in the arm and consider arm development. They are situated at the back-under arm seam.

7) Elbow line: A line that is opposite to the grain line and experiences the turn purpose of the single dart sleeve or the normal rotate purpose of a two dart or three dart sleeves. It fills in as a source of perspective in design improvement.

8) Wrist line: The line over the base of the sleeve that joins the finishes of the underarm pleats.

11.3 Basic sleeve style

11.3 Sleeves fall into three classification - classic, casual, and t-shirt. The sleeve style is fundamentally directed by the height of the sleeve cap.

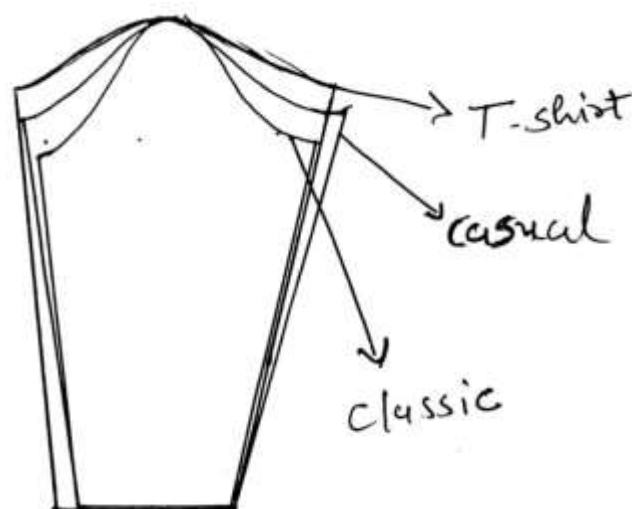

(Fig-3)

11.3.1 Classic sleeve

The classic sleeve is the sleeve found in most traditional custom-made, fitted styles. It tends to be drafted with or without an elbow dart. It ought to be sewn to an arm scye where the shoulder point at the arm scye closes at the shoulder tip, along these lines the arm scye isn't dropped off the shoulder. The classic sleeve is portrayed by a high sleeve cap. The higher sleeve cap is substantially more formal and good-looking when development isn't a need. The armhole depth on the bodice could be raised somewhat to give more opportunity of development without giving up feel.

11.3.2 Casual sleeve

The casual sleeve is a less customized style. The bodice armhole shoulder point is dropped off the shoulder from one half to one inch (1.25 to 2.5 cm). Diagonal wrinkles will frame at the armhole subsequently; be that as it may, more noteworthy opportunity of development is conceivable. The casual styles are a decent trade off among style and portability and between formal classic styles with little opportunity of development and messy shirt styles.

11.3.3 T-shirt sleeve

The shirt sleeve is a casual style. The shoulder point on the bodice armhole is regularly dropped off the shoulder more than one inch (2.5 cm) and the armhole is a shallow bend. Diagonal wrinkles will shape at the armhole subsequently. More noteworthy opportunity of development is conceivable with this style.

11.4 Different types of sleeves

11.4.1 Set in sleeve

Set in sleeves are sewn to the bodice armholes. All set-in sort sleeves must be facilitated, accumulated, shot, or tucked and sewn into the bodice armhole seam. They can be fitted or flared, cut to any length, and their hemlines completed in an assortment of ways.

Set in sleeves are facilitated, gathered, or tucked and sewn into the bodice armhole seam. An assortment of sleeve styles and structure alterations are conceivable, incorporating changes in the sleeve length, measure of fullness, cap height and hemline finishes. On the off chance that an adjustment in the sleeve length is wanted, it is made before extra example work.

An adjustment in the cap stature brings about a sleeve that relates differently to the body than does the fundamental sleeve. The sleeve stands away or simply out from the arm if the sleeve top is abbreviated, where a higher than ordinary cap creates a sleeve that reaches out over the typical shoulder line.

- Basic set-in

Basic set-in sleeves continue the original cap. No changes are made to the cap seam line width or height.

- Three-quarter

It is the least complex structure and is produced using the fundamental sleeve sloper. A three-quarter length can be brought into numerous sleeve designs, for example, straight, bishop, deep armhole, kimono and raglan. The lower edge keeps up the state of another sleeve design.

- Straight

It is a square shape beneath the cap line and is more extensive than the essential sleeve underneath the cap line. This sleeve fills in as an establishment for other sleeve designs.

- Roll-up

The rollup sleeve has a wide stitch and self-cuffs. It is produced using the straight sleeve and has marking to show the fold lines and roll lines. From the fold line, the fabric back out on itself, leaving the sew underneath. This sleeve is commonly utilized for shirts.

- Shirt waist

This is similarly called as shirt marker sleeve. It is a custom fitted sleeve that is finish with a cuff. A placket opening at the lower edge is utilized related to a sleeve to permit section for the hand.

- Added fullness and cap variations

Fullness is added to the sleeves similarly with regards to the next pattern pieces. At the point when fullness is made at the lower edge, a shorter than normal cap is produced, which pulls the sleeve away from the body. At the point when fullness is made at the highest point of the sleeve, a higher than normal cap is produced, which makes the sleeve stand up and out from the shoulder tips. Parallel increases make completion at both the top and base of the sleeve.

1) Bishop sleeve

These are sleeves which are long and are longer at the bottom of the sleeve than at the top. The bishop sleeves are typically accumulated into a neat cuff. Least width of a bishop sleeve is a rectangle shape from the top line down. Design varieties can be created from the basic bishop sleeve. A peasant sleeve is a variety of bishop sleeve where parallel fullness is added to make assembles at the top and lower edge.



Bishop sleeve (fig-4)

2) Bell sleeves

Bell sleeves don't have any pleats and ruffles yet is a flare from elbow to the bottom. The bell sleeve stands from the body falling into easy folds at the lower edge. Bell sleeves might be cut to any length. A-bell sleeve has a smooth cap and a hemline flaring out in the shape of a bell.

Bell sleeves are limited at shoulders are regularly broadens as it arrives at the wrist, particularly beneath the elbow. These types of sleeves slim the shoulders and are normally utilized for little arms. Various styles can be made in these sleeves by cutting any length from the upper arm, the elbow, the lower arm or the wrist.

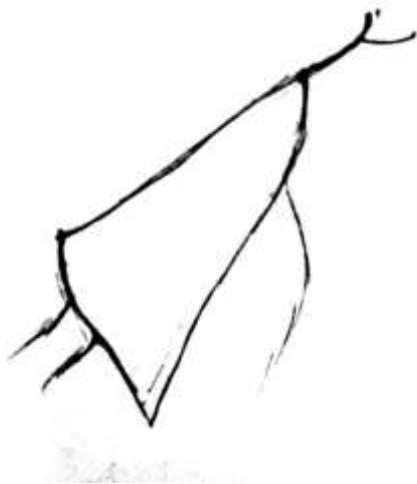

Bell sleeve (fig-5)

3) Cap sleeves

Cap sleeves don't go underneath the armpit level as they are short sleeves. This type of sleeve only covers the shoulder part. Whenever sewn appropriately is very attractive and beautiful. This sleeve is regularly self-lined. The state of the cap sleeve can be formed in variety of different ways.

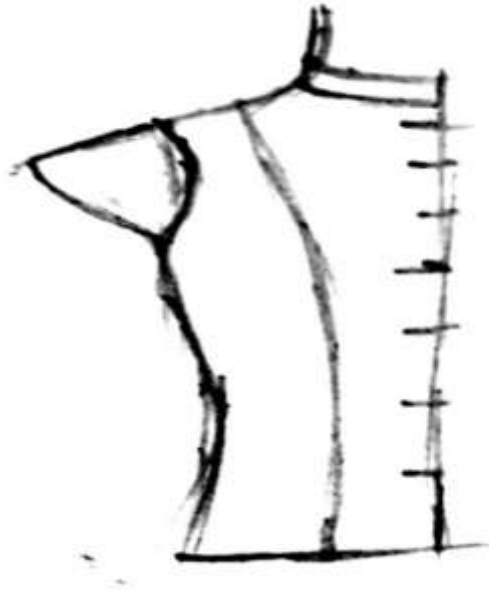

Cap sleeve (fig-6)

4) Gathers at top sleeve

These types of sleeves are commonly seen on many kids' dresses, evening dress or wedding pieces of garments. Puff sleeves can be short (3/4) length or long sleeve. These types of sleeve style are regularly designed as an assemble at the top or bottom of the sleeve. Puff sleeve has fullness added to the body and are commonly designed with assembles at the hemline.



Puff top sleeve (fig-7)

5) Gathers at bottom sleeve

The joined puff-bottom sleeve is like the bell sleeve except for that extra length is added to the lower edge to make a bloused impact over the band



Puff bottom sleeve (fig-8)

6) Balloon/ puff sleeve

Puff sleeves are short which has approximately $\frac{3}{4}$ length or full sleeve that is gathered at the top and bottom. Gathering at the lower edge is constrained by the elastic threading or band. Currently the largest part of this type sleeves can often be seen on wedding occasions and children's garments.

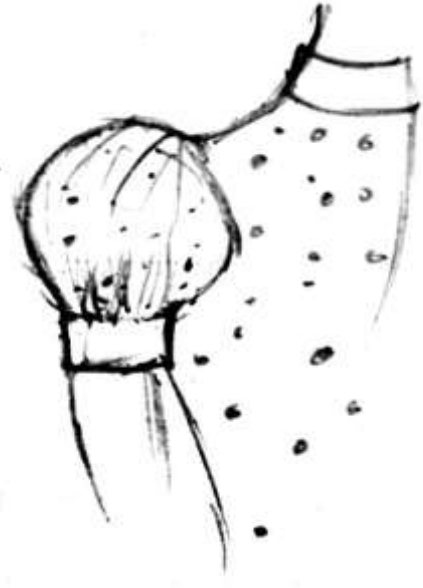

Balloon sleeve (fig-9)

7) Leg-o-mutton

The leg - o - mutton sleeve is named for its similarity to a lamb's leg. It is full from the shoulder to the upper arm and it is tight fitting from the elbow to the wrist. Leg of mutton is created by expanding the biceps and cap region, decreasing the fullness towards the elbow level.



Leg-o-mutton (fig-10)

8) Cowl sleeve

The cowl sleeve has additional top height and width that is made by triangular additions. It is cut on the bias to form shape a hung impact like the cowl neckline area bodice.



Cowl sleeve (fig-11)

9) Dolman Sleeves

Dolman sleeves are long and somewhat slender at the wrist and wide at the top, joining the armhole. Dressmakers consistently cut dolman sleeve as an extension of the piece of clothing and not as a different sleeve to insert.

Dolman sleeves are not sewn to the garments rather the fabric is cut so that the sleeves are a piece of the garments.

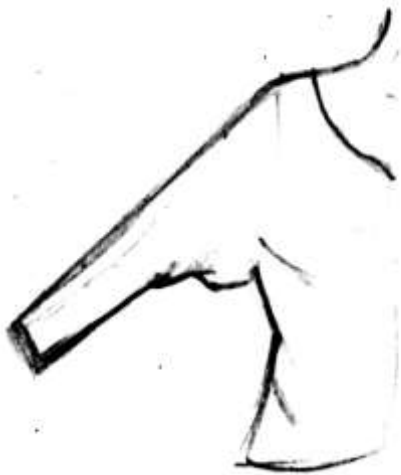

Dolman sleeve (fig-12)

10) Cold shoulder sleeve

This is an off-shoulder style sleeve. The sleeve hangs to the bodice from the sides instead of from the highest point of the armhole leaving a gap uncovering the shoulders.



Cold shoulder sleeve (fig-13)

Two-piece sleeves

Sleeves might be separated on a level plane or vertically into at least two pieces to make varied design effects. At the divisional point, the sleeve may have fullness included. It might be gathered, tucked, pleated or have extensions for covering.

11) Lantern sleeve

Lantern sleeve is a two-area sleeve that flares out from the cap and hemline to a style line inside the sleeve. The lantern or barrel sleeve is cut on a level plane into two pieces at the cap line or beneath and has triangular fullness added to the horizontal seam line.

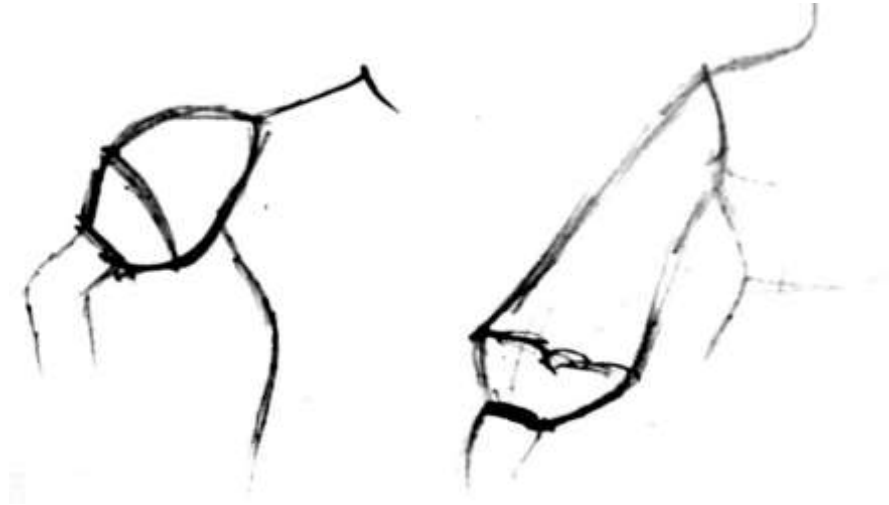

Lantern sleeves (fig-14-15)

12) Petal sleeve

Petal / tulip sleeve is very feminine and flattering variation of set in sleeve the petal, tulip or covered sleeve is a two-piece sleeve that covers at the top point of the arm. Petal sleeve is shaped and looks like a petal as the sleeve areas cross over each other at the top line of the sleeve.



Petal sleeve (fig-16)

13) Tailored

The custom-made sleeve is a two piece, fitted sleeve with two vertical seam lines yet no underarm seam line.



Tailored sleeve (fig-17)

11.4.2 Non set in sleeve

Patterns might be created with the sleeve and the bodice connected, consequently wiping out the armhole seam. Two fundamental sleeves in this category are the kimono sleeve and the raglan sleeve.

1) Kimono sleeve

Kimono sleeves are cut in one with the bodice; the bodice front and the sleeve front are one pattern and the bodice back and the sleeve back are one pattern. The shoulder seam extends from the neck area to the wrist line and is known as the over arm seam. The side seam of the bodice and the underarm seam of the sleeve are participated in one persistent seam line. Design potential outcomes are various.



Kimono sleeve (fig-18)

2) Raglan sleeve

This type of sleeve reaches out from the arm to the neck area. These sleeves have some portion of the upper bodice appended to the sleeve, framing a corner to corner seam line from the neck to the underarm. The diagonal line frequently starts at the neck seam line and goes to the underarm corner of the kimono sleeve. The raglan sleeves are designed in one-piece or a two-piece sleeve. The kind of sleeve can be for the most part observed on any sports top or jersey.

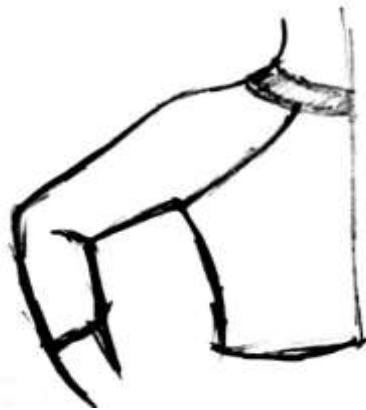

Raglan sleeve (fig-19)

11.5 Standards of a well fitted sleeves

- The armhole curve must be smooth and steady.
- No diagonal wrinkles should be showed up under the arm pit.
- Length wise grains should be straight from armholes to elbow.
- It ought to be cosy fitting and ought not be tight in lower part.
- The sleeve ought to never contort away.
- Wrist line should be in position when arm is bowed
- It should not oversight of the shoulder for style or comfort.

Check Your Progress

1. Write about set in sleeve and not set in sleeve.

2. Different between set in sleeve and non-set in sleeve

3. Write about two-piece sleeve

4. Write about non set in sleeve

5. Write about casual sleeve

Multiple Choice Questions

1. Which sleeve is an example of non-set in sleeve?

- (A) Bell sleeve
- (B) Dolman sleeve
- (C) Kimono sleeve
- (D) Bishop sleeve

2. _____ Sleeve is start of the neckline

- (A) Raglan sleeve
- (B) Cap sleeve
- (C) Leg o mutton
- (D) Petal sleeve

3. Which sleeve is not an example of fullness variation sleeve?

- (A) Bell sleeve

- (B) Cap sleeve
 - (C) Balloon sleeve
 - (D) Gather at top sleeve
4. Which sleeve had fullness to top and bottom is fit?
- (A) Simple sleeve
 - (B) Puff sleeve
 - (C) Cold shoulder sleeve
 - (D) Leg o mutton sleeve
5. _____ sleeve is two-piece sleeve.
- (A) Petal sleeve
 - (B) Lantern sleeve
 - (C) A and B both
 - (D) None

11.6 Let Us Sum Up

The basic sleeve is the foundation for all sleeve variations. The knowledge of adaptation of basic sleeve to different types of sleeves give students the knowledge of their application according to the use and the personality of wearer, because the sleeve is the most important part of the garment which changes the look of the silhouette according to its application.

11.7 Key Words

Accompanying- additional, go with

Indistinguishable- Identical

Abbreviated- shortened

Primarily- mostly

Custom-made- tailored, made to order

Assortment- variety

Below- underneath

Accumulated- gathered

Peasant- labourer, farmer

Lamb's- beef's, chicken's

11.8 Suggested Books

- Zarakar, k(2007, Zarakar system of cutting publish by Navneet publication India Ltd. Dantali Gujarat)
- Reader's Digest "Complete Guide to Sewing"
- Singh, A & Bhardwaj, k (2012 "Textbook of clothing", vista international publishing house, Delhi) First Edition
- Dhruv publisher (2016-2017" Sewing Technology and Dress Making" Ahmedabad) First Edition
- www.wildginger.com

Answers

Check Your Progress

1. There are two types of sleeve
 - i. **Set in sleeve**
 - Bishop sleeve
 - Bell sleeve
 - Cap sleeve
 - Gathers at top sleeve
 - Gathers at bottom sleeve
 - Balloon sleeve/ puff sleeve
 - Leg o mutton
 - Cowl sleeve
 - Dolman sleeve
 - Lantern sleeve
 - Petal sleeve
 - Cold shoulder sleeve
 - Tailored sleeve
 - ii. **Non set in sleeve**
 - Raglan sleeve
 - Kimono sleeve

2. **Set in sleeves** are sewn to the bodice armholes. All set-in sort sleeves must be facilitated, accumulated, shot, or tucked and sewn into the bodice arm scye seam. They can be fitted or flared, cut to any length, and their hemlines completed in an assortment of ways.

Non set in sleeve might be created with the sleeve and the bodice connected, consequently wiping out the armhole seam. Two fundamental sleeves in this category are the kimono sleeve and the raglan sleeve. These sleeves directly connected to neckline. Non set in sleeve have no armhole line.

3. **Two-piece sleeves**

Sleeves might be separated on a level plane or vertically into at least two pieces to make varied design effects. At the divisional point, the sleeve may have fullness included. It might be gathered, tucked,

pleated or have extensions for covering. A portion of the instances of the sleeve styles created by dividing the sleeve into two pieces are

Lantern sleeve

Lantern sleeve is a two-area sleeve that flares out from the cap and hemline to a style line inside the sleeve. The lantern or barrel sleeve is cut on a level plane into two pieces at the cap line or beneath and has triangular fullness added to the horizontal seam line.

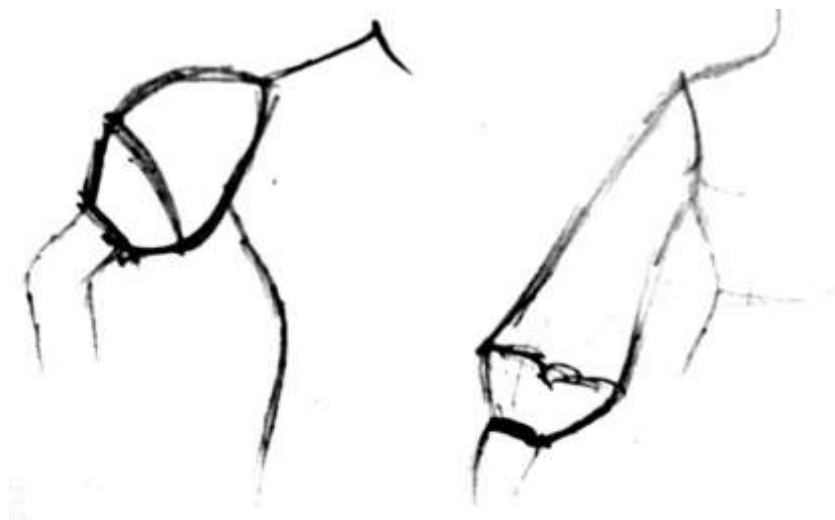

Lantern sleeves

Petal sleeve

Petal / tulip sleeve is very feminine and flattering variation of set in sleeve the petal, tulip or covered sleeve is a two-piece sleeve that covers at the top point of the arm. Petal sleeve is shaped and looks like a petal as the sleeve areas cross over each other at the top line of the sleeve.



Petal sleeve

Tailored

The custom-made sleeve is a two piece, fitted sleeve with two vertical seam lines yet no underarm seam line.



Tailored sleeve

4. Non set in sleeve

Patterns might be created with the sleeve and the bodice connected, consequently wiping out the arm scye seam. Two fundamental sleeves in this category are the kimono sleeve and the raglan sleeve.

1) Kimono sleeve

Kimono sleeves are cut in one with the bodice; the bodice front and the sleeve front are one pattern and the bodice back and the sleeve back are one pattern. The shoulder seam extends from the neck area to the wrist line and is known as the over arm seam. The side seam of the bodice and the underarm seam of the sleeve are participated in one persistent seam line. Design potential outcomes are various.



Kimono sleeve

2) Raglan sleeve

This type of sleeves reaches out from the arm to the neck area. These sleeves have some portion of the upper bodice appended to the sleeve, framing a corner to corner seam line from the neck to the underarm. The diagonal line frequently starts at the neck seam line and goes to the underarm corner of the kimono sleeve. The raglan sleeves are designed so that it very well may be a one-piece or a two-piece sleeve. The kind of sleeve can be for the most part observed on any sports top or jersey.

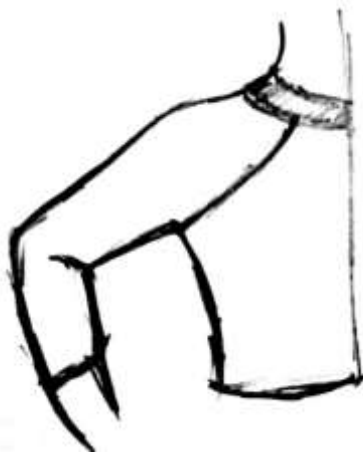

raglan sleeve

5. Casual sleeve

The casual sleeve is a less customized style. The bodice armhole shoulder point is dropped off the shoulder from one half to one inch (1.25 to 2.5 cm). Diagonal wrinkles will frame at the arm scye subsequently; be that as it may, more noteworthy opportunity of development is conceivable. The casual styles are a decent trade off among style and portability and between formal classic styles with little opportunity of development and messy shirt styles.

Multiple Choice Questions

- 1.(C) 2. (A) 3. (B) 4. (D) 5. (C)

UNIT 12 COLLARS

12.0 Objectives

12.1 Introduction

12.2 Collar Terminology

12.3 Types of Collars

12.3.1 Flat Collars

12.3.2 Full Roll Collars

12.3.3 Convertible Collars

12.3.4 Partial Roll Collars

12.4 Classification of Collars

12.5 Designing of Collars

Check Your Progress

Multiple Choice Questions

12.6 Let Us Sum Up

12.7 Key Words

12.8 Suggested Books

Answers

12.0 Objectives

- In this Unit you will be able to knowledge of different types of collars
- To make students aware about use of different types of collars in garments
- Understand the students regarding use and type of collars in making pattern of the garments.
- Selection of the right collars for right garments.

12.1 Introduction

In garments, a collar is the part of a shirt, dress, coat or blouse that attaches around or outlines the neck. Among dress development experts, a collar is separated from different necklines, for example, revers and lapels, by being produced using a different piece of fabric, instead of a collapsed or cut

piece of a similar piece of fabric utilized for the main body of the garments. Collar is attached from garment neckline.

Collar is a design feature that edges the face. It is added to the garments neck edge to make variety in line, shape, colour or texture to upgrade its appearance. Extent and shape are basic in the accomplishment of a collar. It serves to complete the raw edges at the neckline. Collars are typically made of double layers of fabric (with or without an interfacing). In each collar one must recognize the external edge and the internal edge of a collar. The set of the collar, the way it lies and fits at the neck, relies upon the shape of the internal edge or sewing-on edge. This turn depends on the difference in length between the two edges. The collar is joined to the neck area with the external edge hanging free.

12.2 Collar Terminology

1. Collar type: Determined by the shape of the collar neckline. The shape of the collar neckline area straight forwardly affects how a collar relates the wearer's body. A collar may lie against the bodice of the clothes, or it might stand up halfway or completely against the wearer's neck.

2. Neckline: This is the edge of the collar that is connected to the clothes. It is of a similar length as the garments neckline and constantly set apart with notches that compares to the garment neckline.

3. Collar Style: Determined by the shape of the external edge of the collar.

4. Style line: Outer edge of the collar made by the designer.

5. Stand: The collar rises over the clothes neckline that lies against the wearer's neck. A collar might be intended to have no stand or to be full stand.

6. Fall: This is the part of the collar that reaches out from the highest point of the stand to the neckline or beneath to turn into the external part of the collar. It must be as wide as or more extensive than the remain to cover the neck seam line.

7. Roll line: Formed where the collar stands and fall meet; the line at which the collar turns down.

8. Break Point: Point at which a lapel turns back on itself.

9. Upper Collar: Outer obvious one part of a collar.

10. Under Collar: Inner or under piece of the collar. The external seam line of the collar should move to the underside and isn't appeared in the completed product.

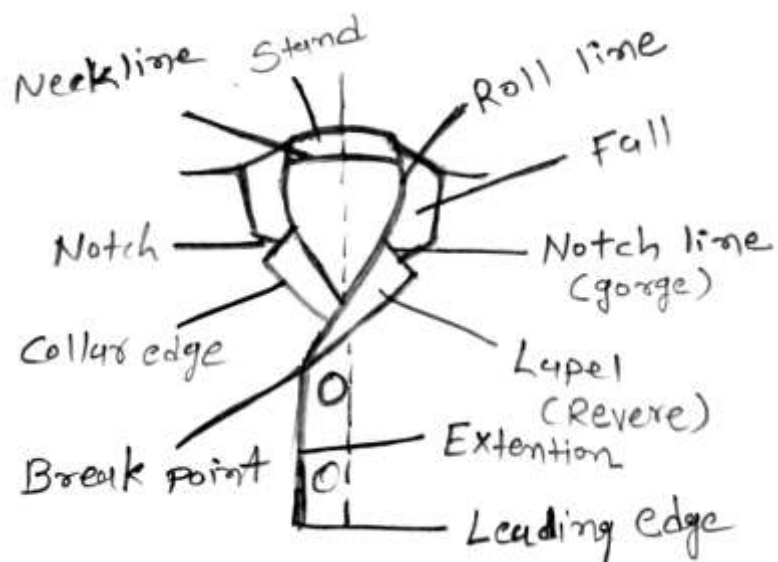

Collar terminology (fig-1)

If both the external and the internal edges of the collar relate fit as a shape and length to its level diagram made on the bodice design, the collar will lie impeccably flat. But if the outer edge is shortened, the collar can never again lie flat and start to stand up and roll over the neck. The greater the contrast between the two edges, the more articulated is this impact and the more positive the move at the neck.

The external edge length just can be changed; the length of the internal edge must continue as before to fit the neckline. However its shape will change and turn out to be less curved. At whatever point the neckline turns over and moves, additional profundity is required. This additional profundity of neckline is a stipend for the stand, which constantly shapes at the neck edge when the external edge of level collar is abbreviated.

Since collars structure a foundation for the face, extraordinary consideration must be taken in designing collar styles, which suit the wearer.

12.3 Types of Collars

There are four basic collar types

12.3.1 Flat Collars

12.3.2 Full Roll Collars

12.3.3 Convertible Collars

12.3.4 Partial Roll Collars

A variety of collars can be developed from these basic collars.

12.3.1 Flat Collars

The length of the neckline should be equivalent to the length of the bodice neckline. A flat collar lies against the body and has no stand. In any case, a slight roll is created with the goal that the collar covers the neck seam line. Peter Pan collars, which lies flawlessly level and has no roll at all. Flat collars anyway can be of any shape-square, pointed etc.



Flat collar (fig-2)

(1) Peter Pan Collar

Peter Pan collar are rounded, the flat collar is raised to as Peter Pan collar. The collar can be designed to have adjusted closures at the front just or at the front and back if separated collar is arranged.

The Peter Pan collar is a type of flat collar, one of the three essential collar types alongside stand and roll collars. It is cut to fit around the collar, following the curve, and to lie flat upon the middle. It can be made either as one section, with a front-affixing bodice, or in two sections to suit a back attaching while at the same time holding the front opening. This type of collar is little and delicate, with adjusted corners.

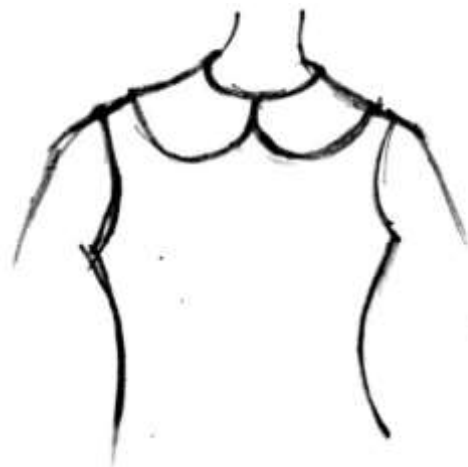

Peter Pan collar (fig-3)

(2) Sailor Collar

The Sailor collar is a flat collar with a V neckline in the front and a square shape at the back. It is generally an expansive collar without a stand and highlights a set things straight back. As a collar without a stand, it is proposed to lay flat on the back and shoulders of the wearer and contains no obvious appearance of a roll. The collar is tailored after the traditional sailor's uniform and is most regularly designed as an appended collar and not a removable one. Most generally sailor collar worn by ladies and youngsters, a sailor collar is a very traditional part of a nautical-themed outfit.



Front

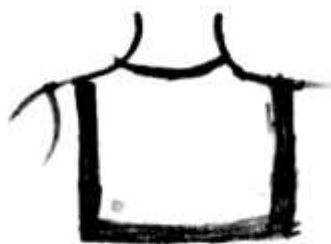

Back

Sailor collar (fig-4-5)

(3) Bertha Collar

A Bertha collar is a wide round flat collar designed to accent a woman's shoulders. It has a long history stretching back to Victorian fashion. It can be worn as accessory to a dress or a top, and it is sometimes removable like a shawl. The first incarnation of the bertha collar was as part of Victorian evening wear. These wide, round collars are regularly made of pleated texture for a rich look.

A Bertha collar is a wide, flat collar that reaches out to the shoulder or beyond to make a cape let impact. Regularly, a bertha collar is connected to a somewhat brought down, round, or boat neckline with the bodice including either a front or back opening.



Bertha collar (fig-6)

12.3.2 Full Roll Collars

The full collar has a full stand and fall at focus back with the stand tapering to nothing at centre front. The neckline edge of the full roll collar is a straight line these are constantly created by drafting from bodice neckline estimations taken from the essential slopes. Garment neckline and the collar neckline are of same length.



Full roll collar (fig-7)

(1) Basic Full Roll

A fundamental full roll collar for of the most part does not surpass 3 – 4 inch in width or the collar would stand up excessively high around the neck. The style line edge of a fundamental full roll collar is a straight line, although structure varieties might be acquainted with the style line to make various impacts.

(2) Bias Full Roll Collar

The bias full roll collar has an equivalent measure of stand and fall circling the neckline, which enables it to fit snugly around the neck. This collar now and again alluded to as turtle neck collar or rolled band collar.

12.3.3 Convertible Collars

A Convertible collar might be worn shut with the garment buttoned or zipped together at centre front or opened to make a collar/lapel impact.

The turned back, upper part of the bodice that starts over the garment conclusion is known as a lapel.

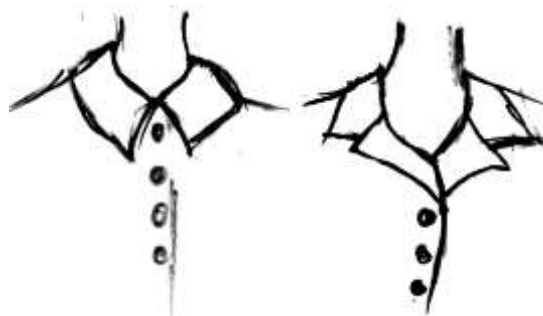

Convertible Collar (fig-8-9)

(1) One-piece and two-piece convertible collars

The fundamental convertible neckline can be designed with

I. The under collar joined to the upper collar along the style line edge to make a one-piece convertible collar

(or)

II. The under collar as a different pattern piece to make a two-piece convertible collar.

(2) Mandarin Collar

The Mandarin Collar is a thin, standing band often 1 to 1 ½ inch wide. Since the neckline is thin, it stands up and has no fall. It very well may be abbreviated to separate at centre front, extended to incorporate a front button/buttonhole expansion, or meet at centre front. Likewise, the front corners can be square or round. This collar can likewise be alluded to as Chinese, Nehru or Military Collar.

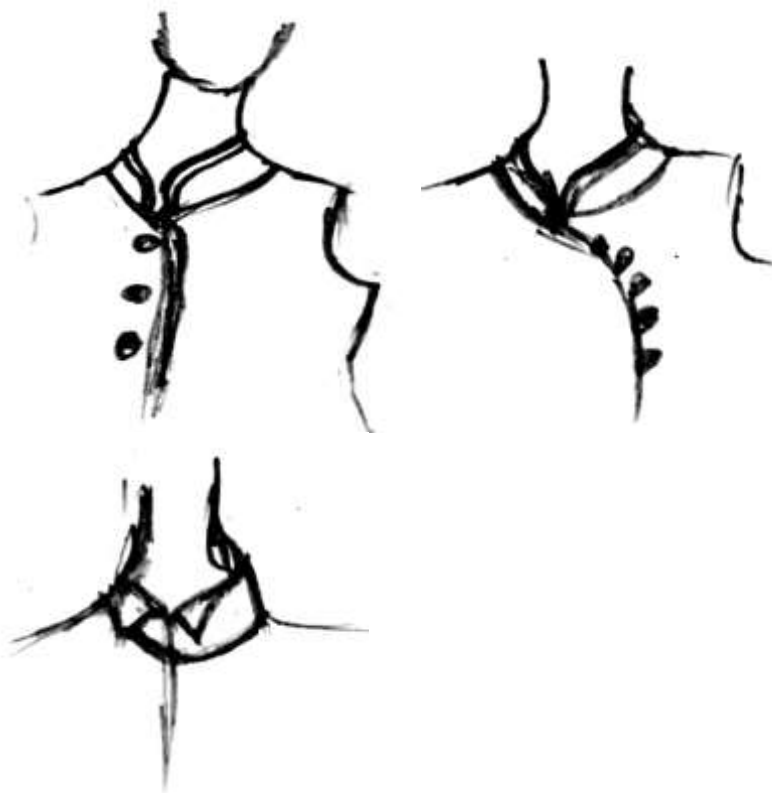

Mandarin collar (fig-10-11-12)

(3) Shirt collar with band

The shirt collar with band is made of two separate pattern pieces, the band and a collar segment. A seam appends the stand and fall of the collar along the roll line. The band or the collar stand is designed with a button/buttonhole termination.



Shirt collar with band (fig-13)

12.3.4 Partial Roll Collars

The Partial Roll Collar has a little remained at centre back with the fall being more extensive than the stand.

(1) Shawl Collars

The Shawl Collar is a design in which the collar and the bodice front are cut as one and the collar segments are seamed together at centre back. At the point when the collar folds over, the front of the garment roll back to make a lapel. This collar consistently is worn open. The fundamental shawl collar is created by appending a full roll collar to the bodice front.



Shawl collar (fig-14)

12.4 Classification of Collars

Collars are characterized by their different qualities, for example,

- Width of the collar
- Shape of its external edge

- Shape of the neck area
- Roll of the collar etc.

12.4.1 Difference in Width and shape of the outer edge

- Peter pan collar is the narrow collar with adjusted closures
- Sailor collar is a wide collar having a square shape at the back and v shape in the front.
- Cape neckline is a wide round collar

12.4.2 Shape of the neckline and roll of the collar

Collars may be delegated rippled, flat, partial roll and standing types the way, the collar rolls (raises up) from the neckline edge or whether it ripples or remain level is dictated by the state of the neckline edge of the garment.

If the centre back edges of every one of these sorts of collar pattern are kept together and their neck area shapes analysed, (the notch demonstrating the shoulder point on the neckline). The neckline curve goes from deep concave (internal curve) in the rippled collar to arched (outward curve) in standing collar. From this the external edge of the collar becomes shorter as the neckline curve becomes straighter.

Disregarding the huge assortment in collar styles, there are specific types which can be perceived as fundamental. By studying these basic collar designs, assembled by the technique for cutting them, one can learn out how to manage a wide range of different collar styles.

12.5 Designing of Collars

Collars can be designed in different shapes and sizes to make assortment. A straightforward collar configuration can be made to look embellishing and individualistic by presenting reasonable trimmings, for example, scallops, frills, tucks, gathers, smocking, buttons, laces, bows, ricrac, embroidery etc. A collar might be removed of material contrasting its colour, design, texture and grain from the garments to deliver fascinating impacts.

For example, a printed dress might be designed with a plain collar or a plain dress with a printed collar, a white or light collar might be utilized on the dull coloured dress or viceversa, etc. For a checked fabric the collar will be compelling if it is cut on bias while the remainder of the garment is cut on straight grain.



Different types of collar design (fig-15)

2.4.1 Factors to be considered while designing collar styles

- (a) Design of the fabric
- (b) Colour and texture of the fabric
- (c) Pattern of the garment
- (d) Purpose and use of the garment
- (e) Sex and age of the wearer
- (f) Appearance of the wearer

Check Your Progress

1. Explain collar terminology.

2. Enlist different types of collar.

3. Describe flat collar.

4. Give the difference between Flat collar and convertible collar.

5. Write about shawl collar.

6. Difference between width and shape of the outer edge of collars.

Multiple Choice Questions

1. Which collar is a flat collar from the following?

- A) Sailor collar
- B) Shawl collar
- C) Peter pan collar
- D) Convertible collar

2. Similar name of cap collar_____.

- A) Full roll collar
- B) Flat collar
- C) Bertha collar
- D) None

3. Which collar is a standing collar from the neckline and measurement 1to1 ½ inch in width?

- A) Convertible collar
- B) One-piece or two-piece collar

- C) Partial collar
- D) Mandarin collar
4. Which garments are used in collar?
- A) Children wear
- B) Dresses
- C) Shirt
- D) All above
5. Which neckline is not collar type.
- A) Square neckline
- B) 'V' neckline
- C) 'C' neckline
- D) A and C both

12.6 Let Us Sum Up

The knowledge of collars is very important for one who undergoes designing courses. Collars are added to the garment neck edge to create variation in line, shape, colour or texture in order to enhance the beauty of garment. Collar is one kind of neck finishing and its edges and it improve functionality of garments such as to decrease depth of the neck of the garments. And improve elegance of the garments. Collar is developing our personality.

12.7 Key Words

Abbreviated- shortened

Impeccably-perfectly

Lies- resting position on a supporting surface, spreading

Fascinating-attractive

Snugly-comfortably

Termination- closure

12.8 Suggested Books

- Reader's Digest "Complete Guide to Sewing"
- Singh, A & Bhardwaj, k (2012 "Textbook of clothing", vista international publishing house, Delhi) First Edition

- <https://www.wisegeek.com/what-is-a-convertible-collar.htm>
- [https://en.wikipedia.org/wiki/Collar_\(clothing\)](https://en.wikipedia.org/wiki/Collar_(clothing))

Answers

Check your progress

1. Collar terminology

If both the external and the internal edges of the collar relate fit as a shape and length to its level diagram made on the bodice design, the collar will lie impeccably flat. But if the outer edge is shortened, the collar can never again lie flat and start to stand up and roll over the neck. The greater the contrast between the two edges, the more articulated is this impact and the more positive the move at the neck.

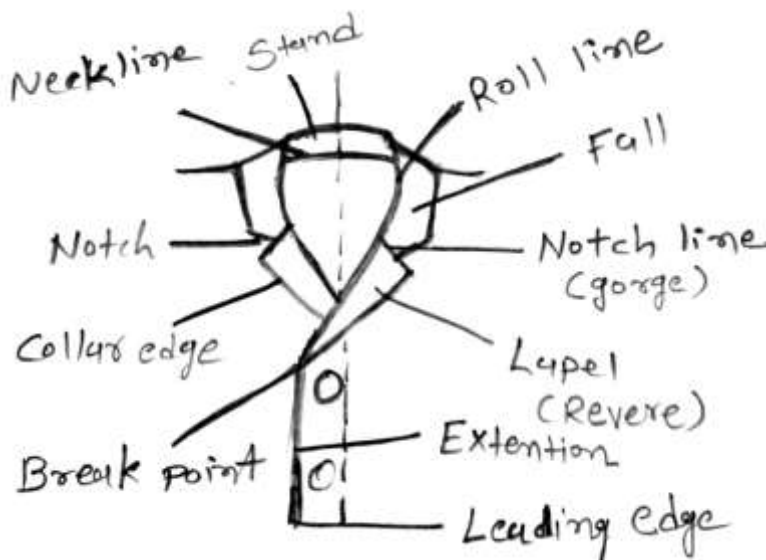

- Collar style: Determined by the shape of the external edge of the collar.
- Style line: Outer edge of the collar made by the designer.
- Stand: The collar raises over the clothes neckline that lies against the wearers neck.
- Collar type: Determined by the shape of the collar neckline. The shape of the collar neckline area straightforwardly affects how a collar relates the wearer's body. A collar may lie level against the bodice of the clothes, or it might stand up halfway or completely against the wearer's neck.
- Neckline: The edge of the collar that is connected to the clothes. It is of a similar length as the garments neckline and constantly set apart with notches that compares to the garment neckline.
- Break point: Point at which a lapel turns back on itself.
- Upper collar: Outer obvious one part of a collar.

- Under collar: Inner or under piece of the collar. The external seam line of the collar should move to the underside and isn't appeared in the completed product.
- Fall: Part of the collar that reaches out from the highest point of the stand to the neckline or beneath to turn into the external part of the collar. It must be as wide as or more extensive than remain to cover the neck seam line.
- Roll line: Formed where the collar stands and fall meet; the line at which the collar turns down.

2. **There are four basic collars**

1 Flat collar

- Peter pan collar
- Sailor collar
- Bertha collar

2 Full roll collars

- Bias full roll collar
- Basic full roll collar

3 Convertible collars

- One-piece and two-piece convertible collars
- Mandarin collar
- Shirt collar with band

4 Partial roll collars

- Shawl collars

3. **Flat collar**

The length of the neckline should be equivalent to the length of the bodice neckline. A flat collar lies against the body and has no stand. In any case, a slight roll is created with the goal that the collar covers the neck seam line. Peter Pan collars, which lies flawlessly level and has no roll at all. Flat collars anyway can be of any shape-square, pointed etc.

1 Peter Pan collar

Peter Pan collar are rounded, the flat collar is raised to as Peter Pan collar. The collar can be designed to have adjusted closures at the front just or at the front and back if a separated collar is arranged.

The Peter Pan collar is a type of flat collar, one of the three essential collar types alongside stand and roll collars. It is cut to fit around the collar, following the curve, and to lie flat upon the middle. It can be made either as one section, with a front-affixing bodice, or in two sections to suit a back attaching while at the same time holding the front opening. The collar is little and delicate, with adjusted corners.



Peter Pan collar

2 Sailor collar

The sailor collar is a flat collar with a V neckline in the front and a square shape at the back. It is a generally an expansive collar without a stand and highlights a set things straight back. As a collar without a stand, it is proposed to lay flat on the back and shoulders of the wearer and contains no obvious appearance of a roll. The collar is tailored after the traditional sailor's uniform and is most regularly designed as an appended collar and not a removable one. A few people have a sailor collar be a separable piece of shirt or dress, be that as it may, in order to offer more than one fashion look. Most generally worn by ladies and youngsters, a sailor collar is a very traditional part of a nautical-themed outfit.

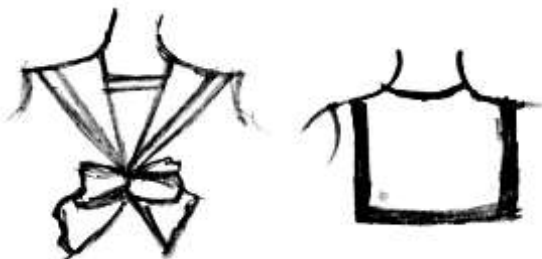

Front

Back

Sailor collar

3 Bertha collars

Throughout the years, the Bertha collar, occasionally called a cape collar in view of its size, has transformed into a genuine cape. Frequently made of trim or with frilly highlights, the cape collar can be effectively expelled to progress from daytime tonight wear. It can likewise be worn as a frill for a wide range of outfits. Some top of the line attire, which has a boat neck as opposed to a full off-shoulder neckline, will likewise use a cape collar. These wide, round collars are regularly made of pleated texture for a rich look.

A bertha collar is a wide, flat collar that reaches out to the shoulder or beyond to make a cape let impact. Regularly, a bertha collar is connected to a somewhat brought down, round, or boat neckline with the bodice including either a front or back opening.



Bertha collar

4. **Flat collar** is cover neck seam line area. Flat collar is equal to bodice neckline. Flat collar generally used in children wear garment. It is cover bodice upper part. Flat collar examples are Peter pan collar, sailor collar, bertha collar

Convertible collar is cover neck area. Convertible collar is stand from neckline these collars is commonly used in gents shirts and ladies kurtas. Convertible collar examples are One-piece and two-piece convertible collars, Mandarin collar, and Shirt collar with band.

5. **Shawl collar**

The shawl collar is a design in which the collar and the bodice front are cut as one and the collar segments are seamed together at centre back. At the point when the collar folds over, the front of the garment roll back to make a lapel. This collar consistently is worn open. The fundamental shawl collar is created by appending a full roll collar to the bodice front.



Shawl collar

- 6.
- 1) Peter pan collar is the narrow collar with adjusted closures
 - 2) Sailor collar is a wide collar having a square shape at the back and v shape in the front.
 - 3) Cape neckline is a wide round collar

Multiple choice questions

1(A) 2 (C) 3(D) 4 (D) 5 (D)

UNIT 13 PLACKETETS

13.0 Objectives

13.1 Introduction

13.2 Plackets

13.3 Standard for Good Plackets

13.3.1 Suitable Length and Convenience

13.3.2 Neatness and Invisibility

13.3.3 Correct Lapping

13.3.4 Suitability

13.3.5 Strength

13.4 Types of Plackets

13.4.1 Inconspicuous Plackets

13.4.1.1 Continuous Bound Placket

13.4.1.2 Bound-And-Faced Placket or Two-Piece Placket

13.4.1.3 Zipper Plackets

13.4.2 Conspicuous Plackets

13.4.2.1 Tailored or Kurta Plackets

13.4.2.2 Faced Placket Open

13.5 Plackets with Cuffs

Check Your Progress

Multiple Choice Questions

13.6 Let Us Sum Up

13.7 Key Words

13.8 Suggested Books

Answers

13.0 Objectives

- In this Unit, you will be able to make the students to understand regarding finishing of opening of garment for male and female.

- Students can learn about types of plackets and its finishing techniques.

13.1 Introduction

Plackets are constructed openings that enable in giving a good fit to the garment. It helps in putting on and tacking off a garment. Plackets are generally attached to waist lines, necklines, wrists and other snug fitting parts of the garment. When the garment is in use these plackets are kept closed with the help of fasteners such as zips, buttons, hooks, eyes, tapes.

13.2 Plackets

A placket is made either in an opening left on the seam or by creating cut or cut in a garment. The placket made in a seam is more grounded and gives a superior completion when finished. The accompanying focuses ought to be remembered while making placket. Neck openings must concede the head effectively, ignore. The situation of the placket ought to be with the end goal that it is effectively open and helpful to work.

13.3 Standard for Good Plackets

A perfect placket should meet the following standards

13.3.1 Suitable Length and Convenience

Placket opening should be admitting the body parts effectively. So, plackets for neck ought to be 9 inches to 12 inches in length. Skirt openings should be long enough (around 7 inches) to guarantee that the garment can disregard the shoulders and hips without strain. Wrist opening can be around 4 inches in length to empower the sleeve to ignore the hand. The situation of the placket ought to be with the end goal that it is effectively open and advantageous to operate.

13.3.2 Neatness and Imperceptibility

A placket ought to be as unnoticeable and flat as could be allowed, except if utilized as a brightening point of interest. It ought not be massive, puckered or extended. Fastenings should hold safely and there ought to be no vast edges.

13.3.3 Correct Lapping

All openings for ladies' garments fasten right over left irrespective of where they are located. For men's articles of clothing, openings should lap left over right when worn.

13.3.4 Suitability

The kind of placket utilized should be appropriate to the type of garment on which it is utilized, its situation in the piece of clothing, surface of the texture, age and sex of the wearer and current styles.

13.3.5 Strength

Openings are exposed to strain during wear and ought to be strength at the closed finishes, e.g lower part of the opening. For plackets in seams to be durable, the clothing seam ought to be at least 5/8 inch wide. Seams ought not be cut or trimmed too close.

13.4 Types of Plackets

Each placket is made of conspicuous or inconspicuous relying upon their position in the article of clothing or according to the style. For the most of the part, all ladies garments utilize inconspicuous plackets and gentlemen custom made pieces of clothing utilize prominent plackets.

13.4.1 Inconspicuous Plackets

Inconspicuous plackets are not seen when the piece of clothing is put on. The continuous bound plackets bound, and confronted plackets and zipper plackets are for example of inconspicuous plackets.

13.4.1.1 Continuous Bound Placket

This is also called One-Piece placket and might be made in a seam or cut. It is generally used for kids' dress, saree petticoats, sleeve openings where a cuff or band is utilized. Do not to utilize this placket on curved seams and on bulky textures.

This placket can be made in an opening made by cut or in a seam opening. To make a placket in a cut, cut a piece of texture on the lengthwise grain, 1 ¼ inch to 1 ½ inch wide and one inch longer than double the length of the opening. Attach the piece to garments opening and machine stitch keeping the opening flat till the middle. Stop the machine keeping the needle inside the texture and push all the material in reverse in order to stay away from a seam in the middle point of the overlap. Keep sewing till the end.

Pressing the seam edges towards the placket strip and overlap under the free edge of the strip ¼ inch and pleats. At that point overlap the strip over the opening edge and sew it along the stitching line.

Fold the strip under on the cover area and tack it at the seam. Attaching can be evacuated after the fasteners are fixed.

Placket in a seam is done in practically comparable manner as placket in a slash. Preceding causing a placket to fortify the seam edges (where the placket closes) with back stitches, cut the seam stipends leaving just ¼ inch allowance. Presently the seam opening is prepared to be done as consistent bound placket.

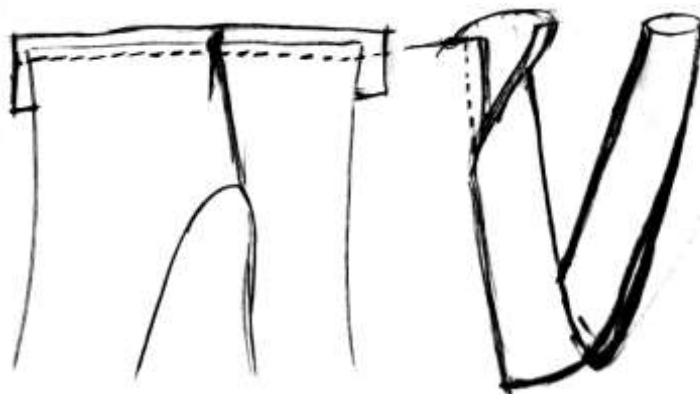

Continuous Bound Placket (fig-1-2)

13.4.1.2 Bound-and-Faced Placket or Two-Piece Placket

This is utilized in the left seam of skirts or saree petticoats and back seam of dresses. The under lap side of this placket is done with an official and the cover with a facing. For this, two separate pieces of texture are utilized. More extensive portion of 2 inches utilized for under lap and narrow strip of 1 ½ inches is utilized for overlay. Both the strips should be 1 inch longer than the placket opening to stretch out underneath the placket opening. The seam allowances of the placket should be same as the seam stipend on which it is made. To complete under lap, crease the strip back over the seam, carrying its free edge to an inappropriate side of piece of clothing, turn under 1/4 inch at the free edge and sew the overlap to the sewing line. This structures the bound side of the placket and should have ½ inch to ¾ inch completed width.

Cut two separate strips of fabric, measuring 8cm width for the overlap and the other with 6cm width for the under lap. The length of strips should be 2.5 cm more than the length of the placket opening. The overlap and under lap sides are finished with the narrow and wide the strips. Care should be taken to maintain the stitching line. The one inch extra length of the strips should extend below the placket opening. Crease the strip back over the seam and turn the wrong side of the garment hem and finish the under lap. The completed bound side of placket should be 0.25 cm wide. Turn the overlap strip over completely to the wrong side making 0.25cm fold on the wrong side of the garment and hem neatly. Finish the placket by raw hand stitches on the wrong side.

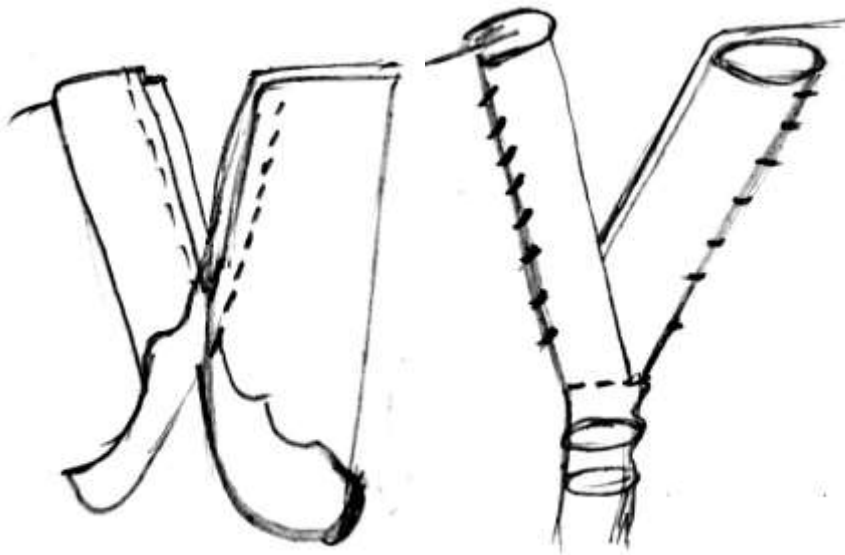

Bound-and-faced placket or two-piece placket (fig-3-4)

13.4.1.3 Zipper Plackets

Zippers are generally joined with tapes and available in various sizes. These can be depending on the size and shade of the placket. Garments with zipper are increasingly alluring and agreeable to the wearer.

There are a few procedures for applying zippers. The decision depends upon the situation of the zipper in the clothes and the types of clothing. Zippers are typically covered either with two covering fabric edges or with one. The previous shows two lines of sewing and is referred as opening seam zipper placket(fig.). The last is called lapped seam zipper placket and just one line of sewing is visible on this.

Cut the opening in garment texture and select the zipper according to the opening size. Close to the part of the arrangement make a short cut $\frac{1}{4}$ " wide corner to corner on both the sides. Turn all the three raw edges to an inappropriate side and do a row of attaching. Take a square piece of Tape and Stitch its raw edge. Join this to the part of the arrangement opening with the stitching. Over this, place the Zipper and stitch through the edges holding the texture edge. At that point take another square piece of Tape and stitch its edge and spot it is covering zipper edge and finish it with hemming.

Zipper must be carefully opened and closed, supposing that the draw tab evades the teeth or rail, it will be hard for the wearer to work it. This can be utilized in skirt, gown, shirt, frock, handbags, decorative purses and different articles of clothing.

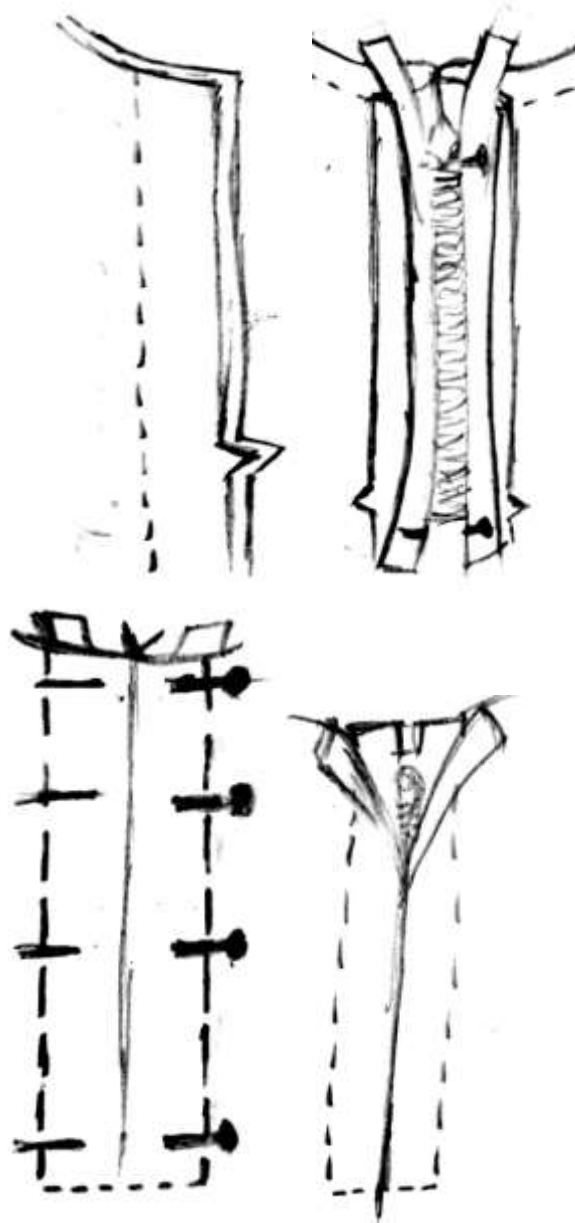

Zipper placket (fig-5-6-7-8)

13.4.2 Conspicuous Plackets

Tailored plackets are conspicuous plackets commonly seen on men's shirt sleeve, on neck openings of kurtas and children's dresses.

13.4.2.1 Tailored or Kurta Plackets

Customized placket is usually utilized on kurtas or men's shirt sleeve openings and on kid's garments. To complete this placket two separate strips are cut for under-lap and over-lap. For under-lap cut one portion of 1 ½ inch wide and precise length of the cut. Keeping one part of the arrangement precisely in accordance with the part of the arrangement and with the correct sides confronting, line a ¼ inch crease joining the edge of the strip to the right edge of the sleeve opening. Presently overlap ¼ inch under on the free edge

of the strip and trim or machine this collapsed under lap strip attached to an inappropriate side of the piece of clothing.

For over-lap take a shaped strip, cut a piece of 2 ½ inch wide and 1 ½ inch longer than the cut. Shape the bottom side of the strip into a pointed 'V'. Keep the correct side of the strip confronting an wrong side of article of clothing and tack the short side of the strip to the free side of the placket opening on the seam line. Machine stitch and bring this overlap strip over the right side of the garment. Turn under the seam allowance and adjust the situation of the strip so that it will overlap the under lap binding. Tack in position.

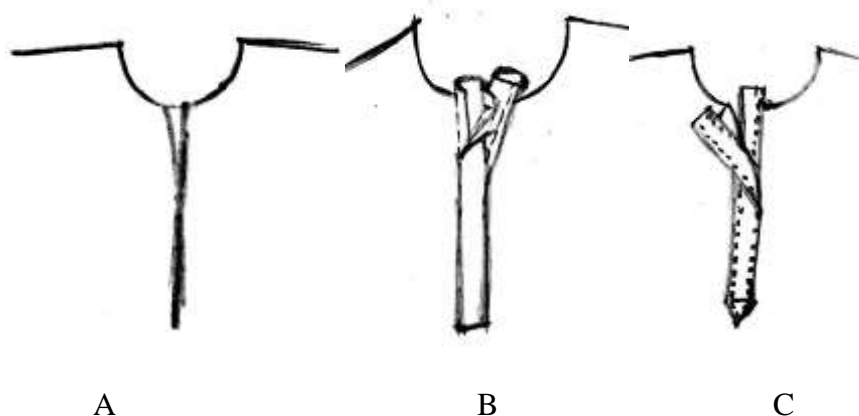

Tailored or Kurta Placket (fig-9-10-11)

13.4.2.2 Faced Placket Open

This is a straight forward neck completion utilized on new-born kid's garments and night dresses. To make this, cut the opening down from the neck at middle front or middle back and apply fitted looking to the opening. Place facing piece right sides facing the article of clothing; do a column of stitchcatching the garment more. Turn the looking to the wrong side and top stich.

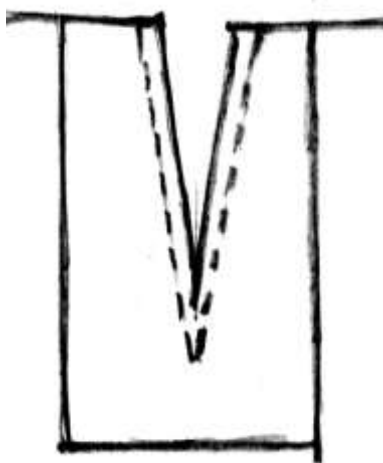

Faced placket open (fig-12)

13.5 Plackets with Cuffs

The three most famous styles are the Lapped sleeve, Shirt sleeve, and French sleeve. Each is built and connected to the sleeve after the placket opening is made at the sleeve edge. The three most ordinarily utilized plackets are the faced placket, continuous bound placket, and Tailored or shirt placket. Note that edges of the faced placket, meet at the opening, while edges of the other two plackets lap. The continuous bound placket is done with a single texture strip to make a narrow lap; the shirt placket is done with two separate pieces to make a more extensive lap.

The lapped sleeve, with a continuous bound placket has one end projecting from placket edge. The shirt sleeve is sewed with its closures adjusted to the under lap and overlap edges of the shirt placket. The French cuff, with a faced placket, is sewed to the placket edges so sleeve finishes meet as opposed to lap, the cuff is cut wide to double back onto itself.

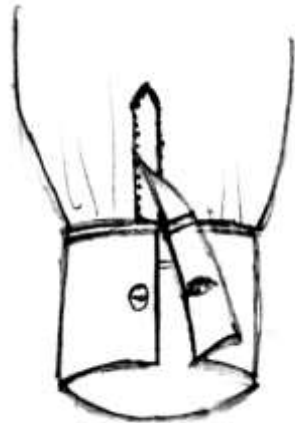

Plackets with Cuff (fig-13)

Check your progress

1. How to maintain quality of good plackets?

2. What are plackets?

3. How to make kurta plackets?

4. Write about Zipper plackets.

5. Describe importance of plackets.

Multiple Choice Questions

1. Which plackets are Inconspicuous Plackets?

- (A) two-piece plackets
- (B) zipper plackets
- (C) tailored plackets
- (D) (A) and (B)

2. _____ plackets generally used in children's garments.

- (A) inconspicuous plackets
- (B) conspicuous plackets
- (C) bound and faced plackets
- (D) none

3. Which plackets utilized for skirts _____.

- (A) conspicuous plackets
- (B) zipper plackets
- (C) two-piece plackets
- (D) none

4. Plackets are used in _____ garment.

- (A) ladies
- (B) gents
- (C) children's
- (D) all above

5. Which is not kind of plackets in following?

- (A) cut plackets
- (B) zipper plackets
- (C) conspicuous plackets
- (D) two-piece plackets

13.6 Let Us Sum Up

Plackets give ease while putting the article of clothing on and off. Subsequently, the plackets ought to be made with appropriate consideration, suitable, reasonable length, right position, quality, right lapping and design. As plackets are commonly closed with help of latches, choice of appropriate clasp is likewise significant. In some cases, plackets are made prominent for useful and beautiful impact.

13.7 Key Words

Snug-warm, cozy

Vast- huge, massive

Tough-roughhard

Confronted-faced

Preceding- Prior, Previous, Earlier

Fortify- support, reinforce

Inappropriate- unsuitable, wrong

Alluring- attractive, appealing, fascinating

13.8 Suggested Books

- Reader's Digest "Complete Guide to Sewing"
- Patel, V (2016 "Sewing technology", Sunrise Publication Co., Rajkot)
- <https://www.textileschool.com/498/types-of-plackets/>

Answers

Check your progress

1. Good plackets are maintaining good qualities like following sentence

Suitable length and convenience

Placket opening should be admitting the body parts effectively. So, plackets for neck ought to be 9 inches to 12 inches in length. Skirt openings should be long enough (around 7 inches) to guarantee that

the garment can disregard the shoulders and hips without strain. Wrist opening can be around 4 inches in length to empower the sleeve to ignore the hand. The situation of the placket ought to be with the end goal that it is effectively open and advantageous to operate.

Neatness and imperceptibility

A placket ought to be as unnoticeable and flat as could be allowed, except if utilized as a brightening point of interest. It ought not be massive, puckered or extended. Fastenings should hold safely and there ought to be no vast edges.

Correct lapping

All openings for ladies' garments secure directly over left independent of where they are found. For men's articles of clothing, openings should lap left over right when worn.

Suitability

The kind of placket utilized should be appropriate to the type of garment on which it is utilized, its situation in the piece of clothing, surface of the texture, age and sex of the wearer and current styles.

Strength

Openings are exposed to strain during wear and ought to be strength at the closed finishes, e.g. lower part of the opening for plackets in seams to be tough, the article of clothing seam ought to be at any rate 5/8 inch wide. seams ought not be cut or cut excessively close.

2. Plackets are done opening developed to make it simple to put on or remove a garment. The placket openings in the garment are kept shut with the guide of fasteners, for example, zips, button and buttonholes, press buttons, hooks and eyes and so on., when the piece of clothing is put on. They are utilized at waistlines, neck lines, wrists and other snug fitting pieces of articles of clothing. A placket might be made in an opening left in a seam, or in a cut in a piece of clothing. The previous is more grounded and gives a superior completion when finished.
3. First kurta placket start with two separate strips are cut for under-lap and over-lap. For under-lap cut one portion of 1 ½ inch wide and precise length of the cut. Keeping one part of the arrangement precisely in accordance with the part of the arrangement and with the correct sides confronting, line a ¼ inch crease joining the edge of the strip to the right edge of the sleeve opening. Presently overlap ¼ inch under on the free edge of the strip and trim or machine this collapsed underlap strip attached to an inappropriate side of the garment. For over-lap take a shaped strip, cut a piece of 2 ½ inch wide and 1 ½ inch longer than the cut. Shape the bottom side of the

strip into a pointed 'V '. Keep the correct side of the strip confronting an inappropriate side of the garments.

4. Zippers are available different variety and size. We can use in garments, purses, bags, and Many more. Zipper must be carefully opened and close. These can be depending on the size and shade of the placket. Garments with zipper are increasingly alluring and agreeable to the wearer. There are a few procedures for applying zippers. The decision depends upon the situation of the zipper in the clothes and the types of clothing. Zippers are typically covered either with two covering fabric edges or with one. The previous shows two lines of sewing and is referred as opening seam zipper placket. The last is called lapped seam zipper placket and just one line of sewing is visible on this.
5. In garments plackets are very important.Plackets give ease while putting garment on and off.Plackets are made by interfacing more layers of a fabric to impart strength and support to the garment as it is subjected to stress when worn. When we can used plackets in garments are easily open and close.

Multiple Choice Questions

1 (D) 2 (B) 3 (C) 4 (D) 5 (A)

UNIT 14 FASTENERS

14.0 Objectives

14.1 Introduction

14.2 Selection of Fasteners

14.3 Buttons

14.3.1 Buttons with Holes

14.3.2 Shank Buttons

14.3.3 Decorative Buttons

14.3.4 Link Buttons

14.4 buttonholes

14.4.1 Marking of Buttonholes

14.4.2 working of Buttonholes

14.5 Hooks and Eyes

14.5.1 Stitching Of Hooks and Eyes

Check Your Progress I

14.6 Button Loops

14.6.1 Thread Loops

14.6.2 Fabric Loops

14.6.3 Corded Loops

14.6.4 Corded Frogs

14.7 Snaps or Press Buttons

14.7.1 Stitching of Snaps

14.8 Zippers

14.8.1 Conventional Zippers

14.8.2 Separating Zippers

14.8.3 Invisible Zippers

14.9 Elastic

14.10 Tapes and Cords

14.11 Velcro

14.12 Buckles

14.13 Broaches

Check Your Progress II

Multiple Choice Questions

14.14 Let Us Sum Up

14.15 Key Words

14.16 Suggested Books

Answers

14.0 Objectives

- In this Unit, you will learn how to apply different types of fasteners.
- How stitching fasteners depend in various parts in garments.
- Selection of right fasteners over the other for a particular garment.

14.1 Introduction

The basic fasteners are buttons, hooks and eyes, eyelets and cords, press button, buckles, elastic, Velcro etc.

There are different kinds of fasteners, some are fancy and conspicuous. This kind of fasteners selected will depend on the position. It is important to remember with all types of closures that the two side of the opening match perfectly without any pulling or gaping of the fabric and give a neat appearance to the garment.

In general, fasteners ought to be fixed on to double layer material for strength. Fasteners should be chosen to suit the shading, design and surface of the texture, the style and utilization of the garment and the situation of the placket. Button and buttonholes are commonly utilized for men's shirts, pants etc, and similarly as press button and snares and eye are generally utilized for women's cholis and kids' dresses.

14.2 Selection of Fasteners

14.2.1 Care

Press button, hooks eyes, on an article of clothing which are often washed and pressed are effectively harmed

14.2.2 Strain

Hooks and eyes give an undetectable closing which is especially reasonable when there is cross wise strain.

14.2.3 Fasteners Combination

Combination of fasteners will consistently give best closing, for instance utilization of zippers and buttons and buttonholes in jeans.

14.2.4 Quality

Quality of the fasteners is very essential as press buttons are less secure than catches and buttonholes.

14.2.5 Correct Lapping

Fasteners ought to be fixed so that the correct side of the garment laps over the left side for ladies and the left laps over the privilege for men.

14.3 Buttons

Buttons are chosen very carefully to suit both the weight and shade of the texture. The benefits of utilizing buttons as terminations are various. They are both useful and decorative. They ought to be sewn safely by a solid thread so that it enables the buttonholes to close under the button without puckering the texture.

Buttons are put middle on the inside up-front back lines of the clothing aside from in unusual cases. The width of dividing shifts as per the situation of opening, texture weight and size of buttons. Excessively few or too many can spoil the presence of the completed article of clothing. On a shirt or blouse the buttons must be set to avoid from expanding over the bust or waist. On a waist area of the clothes a button should consistently be utilized on the grounds that this is the emphasize purpose of the garments.

14.3.1 Buttons with holes

These are commonly utilized buttons which are sewn flat through the holes from upper side of the texture. Buttons are available with two or four holes. They might be made of bone, glass, metal, plastic and many more.

Sew these kinds of buttons utilizing double thread. Bring the needle here and there through the holes in the buttons with a pin kept over the button. After to working enough stitches, remove the pin, lift the button and structure a shank by winding the thread tightly around the strands about many times. Now fasten the thread on the wrong side. Button with four holes might be sewn in the shape of a cross, two parallel lines, a square or an arrow point.

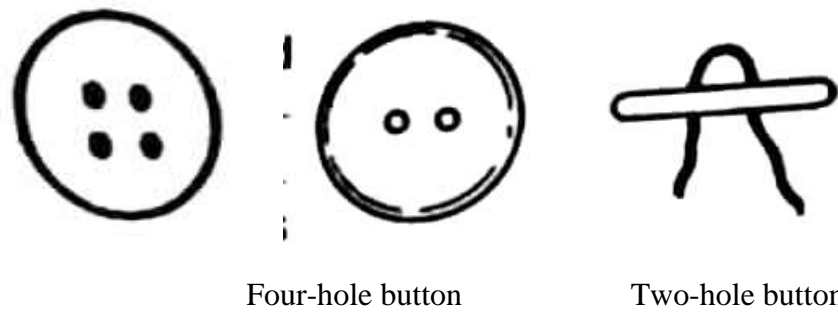

Four-hole button

Two-hole button

(Fig-1)

14.3.2 Shank Buttons

These are joined to the garment from the underside with a little circle on the lower side of the button. There are two kinds of shank buttons. Join button and secured buttons. Secured buttons might be made of fabric. On dresses buttons covered with self-fabric might be utilized. Pieces of fabric are utilized to get the fabric button covered by a special machine. Covering might be finished by hand also.

Bring needle through texture and shank loop at the base of the button and after that back through texture. Stitch through texture and shank until button is verified. Attach thread on underside.

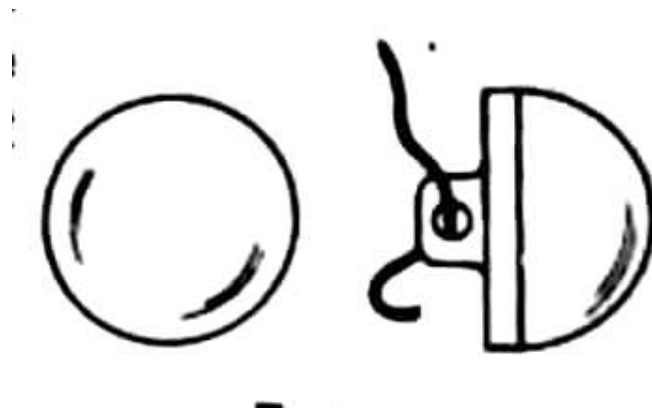

Shank button (fig-2)

14.3.3 Decorative Buttons

Decorative buttons are commonly utilized for decorative purpose. They are mainly false buttons which are utilized for not closing the placket. It is worked away at the correct side of the garment. Decorative buttons are regularly utilized on kids' or women clothes. They are available in the market in wide range of colour, shapes, textures and made of various materials like fabric, plastic, metal, wooden etc.



Decorative Buttons (fig-3-4-5)

14.3.4 Link Buttons

Link button used for sleeves of shirt for the front of coat or a jacket. The sleeve has two buttonholes, one on each side of the placket opening. Cuff links have flat surface and loops with fits in both buttonholes and lock the sleeve.



Link Button (fig-6)

14.4 Buttonholes

Buttonholes are slits cuts in garments to hold buttons in place. They are made on the cover segment of the garment opening in line with the button on the under lap. The length of the buttonhole ought to be the measurement of the button in addition to around 1/8 inch. They are put to such an extent that when shut, the button lays on the middle point of the buttonhole. The cuts are made vertically or horizontally on the garment. The raw edges of these slits can either be hand or machine worked or fabric bound buttonholes.

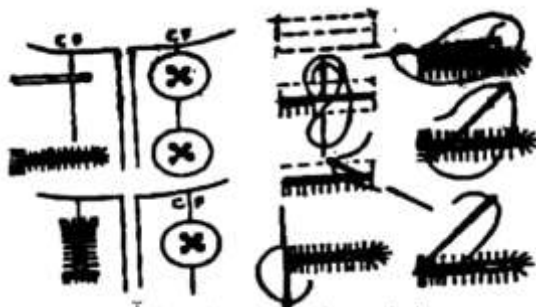

Buttonholes (fig-7)

14.4.1 Marking of Buttonholes

Button holes are in two different types one is vertical, and another is horizontal. It depends on the position of the plackets opening.

Vertical buttonholes are regularly utilized with a thin placket where less strain included, for example, a shirt band, or where there are numerous little buttons involved in closing the garment. They are put parallel to the length wise grain of the clothes. They are put on the button position line and the highest point of the buttonhole is 3mm over the mark for middle point of button.

Horizontal buttonholes are the most secure and along these lines utilized on most clothes where strain is included. When buttoned, the pull of the closure is absorbed by the end of the buttonhole with little distortion. These buttonholes are set to expand 3 mm beyond the button position line.

14.4.2 Working of Buttonholes

Whatever might be the marking of the cut used to make the buttonhole, they should be worked to complete its raw edges. The raw edges of these cut can either be hand worked with buttonhole stitch, machine worked utilizing zig zag stitches or fabric bound buttonholes utilizing self or difference texture. The technique you decide for a garment will rely upon the design of that garment, the texture and your capacity to sew.

Hand work buttonholes utilized in kids and men clothes and are worked after the finishing garments. Hand worked buttonholes made with matching thread. Worked buttonholes are made twofold texture, facings, collars and sleeves must be finished first. Mark the centre point of the buttonhole with a column of attaching. Try not to cut. Stitch around the whole buttonhole utilizing fine hand-running stitch to show the width of sewing. Fold the buttonhole start to finish and make a little cut in the centre with a sharp pointed scissors.

Open cut and slash to each end. Leaving thread unknotted take a back stitch on the wrong side close to the end part of the buttonhole. Bring the needle out through the buttonhole to the correct side. With the correct side of the garment up, hold the cut buttonhole over the finger of your left hand and work the buttonhole utilizing buttonhole stitch.

For the vertical buttonholes, both the closures are done in a similar shape, either fanned or bar tacked. Be that as it may, for the horizontal buttonholes, the external end is fanned to suit the catch shank and the internal end is bar-tacked to give strength.

Machine worked buttonholes generally used in readymade shirts. It is possible with a automatic machine or with a ordinary machine which has a buttonhole attachment.



Working of Buttonholes (fig-8)

14.5 Hooks and Eyes

Hooks and eyes are used in placket where there is crosswise strain. They structure an unnoticeable shutting. The hook should be put 1/8" inside the completed edge of the cover on a wrong side. Bring the buttonhole stitches or overcast stitches around the rings of the hooks and at the middle point of the hook. At that point slip the needle through the texture and bring it out close to the hook end. Take a few back stitches crosswise over and under the loop of the hook to hold it down firmly. Secure off with little back stitches, without appearing on the correct side. Hooks and eyes are used in highest point of the zippers and ladies skirts also.

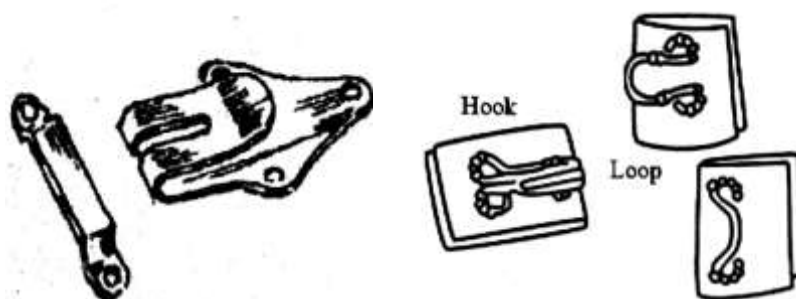

Hooks and eyes (fig-9)

14.5.1 Stitching of Hooks and Eyes

The hook is constantly sewn on to the back of the cover and positioned with the goal that the part of the hook does not extend more distant than the edge of underlap of the garment. Over sew each loop and across the bar of the hook. Position the metal bar or eye on the opposite right side of the under lap and over sew around the loops. The hook and eye should seem imperceptible when fastened.

Sometimes, a thread eye can be utilized as a substitute for a metal eye. A thread eye isn't as solid as a metal eye; hence ought not to be utilized at places where there is much strain. To shape a thread eye, utilize a single strand of substantial thread or twofold strand of regular sewing thread of colour matching with the texture. A thread eye should be if the space between its two arrangements marks. Add needle into texture at one mark and bring it up at the other mark. Apply 2-3 additional stitches similarly. Spread every one of the strands with closely spaced blanket stitches, taking consideration not to get the texture underneath. Whenever wrapped up, the needle and thread to an inappropriate side and attach safely.

Check Your Progress I

1. Write about holes with buttons.

2. Write use of buttonholes.

3. Which stitch is used to fasten a press button?

4. How will you stitch a hook and eye in a garment?

14.6 Button Loops

Buttonholes, loops might be utilized to fasten buttons. These might be made of thread or fabric.

14.6.1 Thread Loops

The thread loop is an unnoticeable attaching which is frequently found at the neck edge of collars. To make a thread loop, sew four or five strands of matching thread on the under lap in the right position, work buttonhole stitch over these strands.

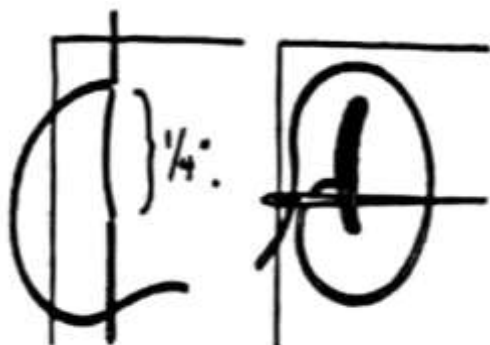

Thread loop (fig-10)

14.6.2 Fabric Loops

These are made of pieces of bias fabric sewed and turned back to front to frame a narrow tube. The fabric utilized might be of self-material or harmonizing material. This kind of attaching adds a decorative trim to kid's and ladies garment. Buttons matching to the fabric loops are fixed on the under lap.

14.6.3 Corded Loops

These are made a similar way as matching cloth loops aside from that a cording is set inside the bias strip.

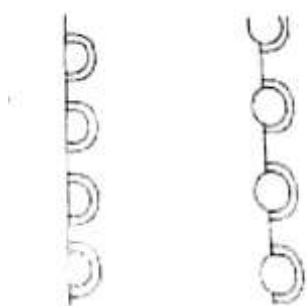

Cords Loops (fig-11)

14.6.4 Corded frogs

Corded frogs are decorative and made in various designs. Button loops of the frog should be long enough to slip over button easily.

They are made by shaping fabric tubes into an expensive design. It is a highly decorative attaching which additionally serves the function of

appropriately shutting a garment. It is also called a Chinese frog loop and goes very well with mandarin neckline found in Chinese garment.

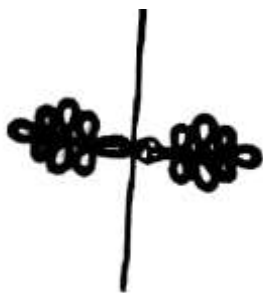

Cord Frogs (fig-12)

14.7 Snaps or Press Buttons

Snaps or press are a sort of little fasteners having less holding force than snares and eyes. It is ideal to utilize them where there isn't much strain on the opening. Each snap has two sections - a ball or knob and a socket. General-purpose snaps extend in size from fine to heavy. They will open out whenever utilized on cosy fitted parts. These are accessible on different sizes and weight. They are either dark or silver.

Other snap types are secured snaps, no-sew snaps and snap tape. Secured snaps are planned for use on garment, for example, coats, where it is attractive that the snap is not clear when the garment is worn open. No-sew snaps are solid fasteners that are not sewed to the garment, but cleaved into the fabric. Snap tape has the ball half of the snap on one tape and the socket half on the other. The tapes can be machine or hand sewed on rear of the cover and right half of the under lap. This fastener is perfect for sportswear and children wear.

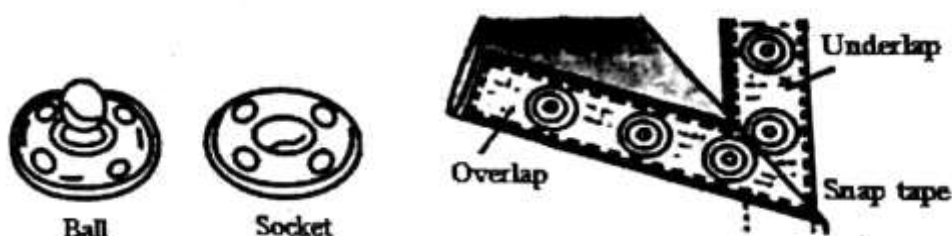

Snaps or press buttons (fig-13)

14.7.1 Stitching of Snaps

The knobs are sewed on wrong side of the cover near the edge and should take care to see that the stitches that fasten the button to the overlap do not show on the correct side of the garment. Press the knob against the

under lap to form the slight impression to place the socket. Spot the attachment side of the snap focus over impression and stitch.

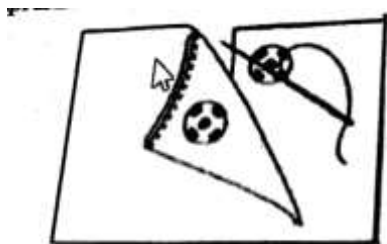

(Fig-14)

14.8 Zippers

Zippers are available in a various colours, sizes and types. A few sorts of zippers are available. Three kinds of zipper are available conventional, separating and invisible zippers. All zippers comprise of either a chain of metal or plastic teeth or a synthetic coil joined to fabric tapes. Chains and coil are made in many sizes, spirals of polyester or nylon. Coil zippers are lighter in weight, and generally progressively adaptable. Metal zippers are less affected by heat.

Zipper tapes are woven, by and large of cotton or a mix of cotton and polyester. A few tapes for coil zippers are stabilized nylon or polyester weave. Zippers are opened and shut by methods for a slider or runner with a handle like tab that moves it here and there the coil or chain. Top and bottom stop the slide from running off the zipper with metal teeth.

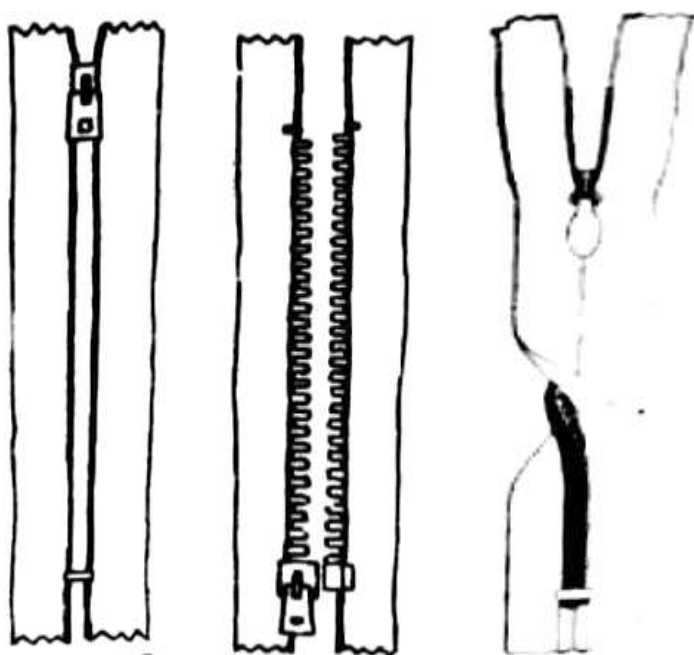

1) Conventional zipper, 2) Separating zipper, 3) Invisible zipper

(Fig-15-16-17)

14.8.1 Conventional Zippers

These zippers, regardless of whether made with uncovered teeth (chain) or twist, open at the top and are held together at the base. They come in increasingly unexpected styles in contrast with some other zipper type. Dependent upon the piece of attire structure, application may be by the focused, lapped, revealed, or fly system.

14.8.2 Separating Zippers

Separating zippers are made to open at both top and bottom, allowing the zipper opening to separate totally. These is utilized for the most part on coats, they can be connected to any garment with a completely opened front. Additionally, double reversible and two-way zippers that zip from the top and bottom are available for jumpsuits and similar clothes.

14.8.3 Invisible Zippers

Invisible zippers are latest and very useful zipper. As the name infers, they are organized uniquely in contrast to different zippers and are in a special way so that they vanish into a seam. At the point when perfectly connected, neither the sewing nor the zipper teeth or coil is visible on the front side of the garment. Invisible zippers are utilized skirts and dresses. While a conventional zippers may be utilized in a pants.

Different kind of zippers includes two-way zipper, pant zipper and decorative zipper with large teeth and a pull ring.

14.9 Elastic

Elastic is available in different kind of widths. The types of elastic to choose will depend on whether it will be used in a casing or stitched directly to a garment.

1. **Braided elastic:** This is suggested only for casing because it narrows when stretched.
2. **Woven elastic:** The width of the elastic remains same even when extended thus can be sewed directly to the clothes or for casing.
3. **Elastic thread:** It is very thin covered elastic. It is generally utilized in bobbin for shirring effect in garment. Since it is twisted in bobbin for shirring it is called bobbin elastic.
4. **Special purpose elastic:** Special elastics are used in night robe, lungies and swimwear.

14.10 Tapes and Cords

Various kinds of tapes and cords are available which are both practical just as decorative. They arrive in different types, widths and colours and its selection should depend basically on its end use.

1. **Seam Tape:** Seam tapes are woven or trim tapes. They are utilized to complete sew and facing edges.
2. **Binding Tape:** Binding tapes are utilized for binding curved or straight edges and facing edges.
3. **Twill Tape:** Twill tapes are for the most part utilized for reinforcing seams.
4. **Piping:** Piping tapes are narrow bias Patti of fabrics that can be inserted into a seam for decorative purpose.
5. **Hem Facing:** Hem facing tapes are wide bias tape or trim which is utilized on facing hems and binding edges.
6. **Ribbon Tape:** Ribbon tapes are weave ted groups which are stretchable and can be utilized to complete neck areas, arm gaps, sleeve, leg or waistline.

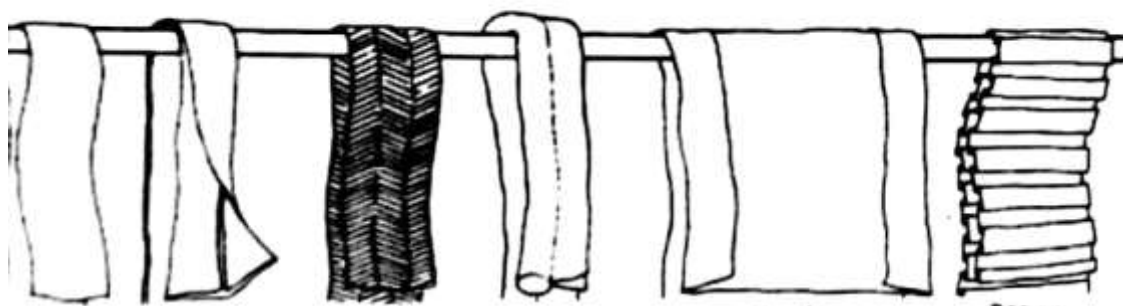

Tapes and Cords (fig-18)

14.11 Velcro

Velcro is the two tape strips surface. Velcro is a set of two tapes one with a looped napped surface and other with a hooked napped surface. When pressed together, surfaces grip and remain locked until pulled apart. These are used on cuff, plackets, mosquito nets and other such items. They are usually made of nylon and are available in meters and yards. Velcro is popular in infant garments. These tapes come in sew-on, iron-on and stick on forms.

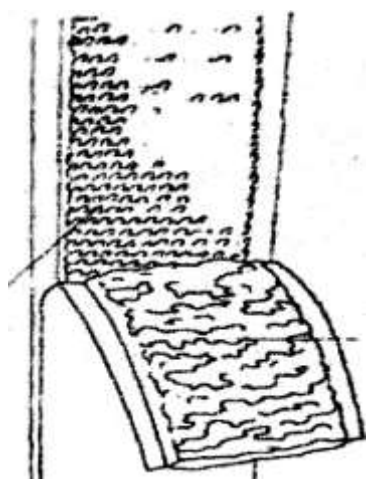

Velcro (fig-19)

14.12 Buckles

Buckles are available in many varieties in market. Buckles are available in Plastic, Iron, Brass, Steel, etc materials. However, there are only two types of buckles—buckles with prongs which eyelets attached with and buckles without prongs which is not available in eyelets. Readymade metal eyelets can be applied with special plier or attaching tool, or eyelets can be hand sewn using a buttonhole stitch. Buckles are one of the most interesting types of fasteners.

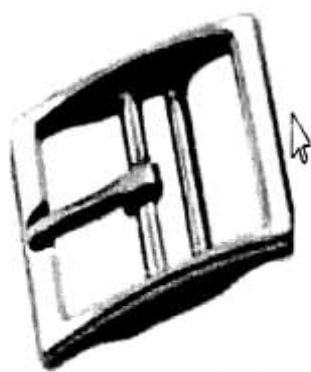

Buckles (fig-20)

14.13 Broaches

They are a decorative item with a catch and a pin, which are fastened to the cloth. They serve as a functional as well as decorative fastener though the decorative element is more. They are usually embellished with gems and decorated heavily. Broaches made in metal and generally used for decoration on the garment.



Broche (fig-21)

Check Your Progress II

5. Write about any one type of zipper with diagram.

6. Explain different types of elastic.

7. Explain about Velcro.

8. Write about broaches.

Multiple Choice Questions

1. Hand work buttonhole mostly used in _____ garments.
(A) Women
(B) girls
(C) kid's
(D) all above
2. Which tape is used to reinforce the seam?
(A) Seam tape
(B) Twill tape
(C) Piping
(D) Ribbing tape
3. With which the buttonhole is used?
(A) Button
(B) Buckle
(C) Press buttons
(D) Hook
4. Which tape is a stretchable knitted band?
(A) Seam tape
(B) Ripping tape
(C) Piping
(B) Twill tape
5. There are _____ types of buckles.
(A) 5
(B) 2
(C) 3

- (D) 4
6. Which elastic is used for shirring?
 (A) Woven elastic
 (B) Braided elastic
 (C) Thread elastic
 (D) Special purpose elastic
7. Which zippers open to both sides?
 (A) Separating zipper
 (B) Invisible zipper
 (C) Conventional zipper
 (D) A and B both

14.14 Let Us Sum Up

All the garment openings should be closed with the guide of fasteners. They should be fixed in, for, way that the correct side of the garment laps over the left side for ladies and left over ideal for men. Fasteners should be chosen to suit the colour, design and surface of the texture, the style and utilization of the garment and the situation of the placket. One should also consider the age and sex of the wearer. Hooks and eyes, buttons, buttonholes, snap, texture loops are a portion of the fasteners that might be utilized as fasteners.

14.15 Key Words

Undetectable- invisible, imperceptible

Terminations-closes, finishes

Ordinary-normal, usual

Strain-rinsing-straining

Underneath- beneath, under

Harmonizing-matching

Sorts-types, kinds

Shut- closed, locked, finished

Vanish-disappear

14.16 Suggested Books

Patel, V (2016 “Sewing technology”, Sunrise Publication Co., Rajkot)

Reader’s Digest “Complete Guide to Sewing”

<https://sewguide.com/sew-fasteners/>

https://www.brainkart.com/article/Plackets-and-Fasteners_35632/

Answers

Check Your Progress I

1. Buttons are used ordinarily utilized buttons which are sewn flat through the holes from upper side of the texture. Buttons are available with two or four holes. They might be made of bone, glass, metal, plastic and many more.
Sew these kinds of buttons utilizing double thread. Bring the needle here and there through the holes in the buttons with a stick kept over the button. After to working enough stitches, remove the stick, lift the button and structure a shank by winding the thread tightly around the strands around many times. Presently secure the thread on an inappropriate side. Button with four holes might be sewn in the shape of a cross, two parallel lines, a square or an arrow point.
2. Buttonholes are cuts in garments to hold button in this place. They are made on the cover segment of the garment opening in line with the button on the under lap. The length of the buttonhole ought to be the measurement of the button in addition to around 1/8 inch. They are put to such an extent that when shut, the button lays on the middle point of the buttonhole. The cuts are made vertically or horizontally on the garment. The raw edges of these cuts can either be hand or machine worked or texture bound buttonholes.
3. The knobs are sewed on wrong side of the cover near the edge and should take care to see that the stitches that fasten the button to the cover don't appear on the correct side of the garment. Press the knob against the under lap to form the slight impression to place the socket. Spot the attachment side of the snap focus over impression and stitch.
4. Hook is constantly sewn on to the back of the cover and positioned with the goal that the part of the hook does not extend more distant than the edge of underlap of the garment. Over sew each loop and across the bar of the hook. Position the metal bar or eye on the opposite right side of the under lap and over sew around the loops. The hook and eye should seem imperceptible when fastened. Sometimes, a thread eye can be utilized as a substitute for a metal eye. A thread eye isn't as solid as a metal eye; hence ought not to be utilized at places where there is much strain. To shape a thread eye, utilize a single strand of substantial thread or twofold strand of regular sewing thread of colour matching with the texture. A thread eye should be if the space between its two arrangements marks. Add needle into texture at one mark and bring it up at the other mark. Apply 2-3 additional stitches similarly. Spread every one of the strands with closely spaced blanket stitches, taking consideration not to get the texture underneath. Whenever wrapped up, the needle and thread to an inappropriate side and attach safely.

Check Your Progress II

5. Zippers are available in a various colours, sizes and types. A few sorts of zippers are available. Three kinds of zipper are available conventional, separating and invisible zippers. All zippers comprise of either a chain of metal or plastic teeth or a synthetic coil joined to fabric tapes. Chains and coil are made in many sizes, spirals of polyester or nylon. Coil zippers are lighter in weight, and generally progressively adaptable. Metal zippers are less affected by heat.

Zipper tapes are woven, by and large of cotton or a mix of cotton and polyester. A few tapes for coil zippers are stabilized nylon or polyester weave. Zippers are opened and shut by methods for a slider or runner with a handle like tab that moves it here and there the coil or chain. Top and bottom stop the slider from running off the zipper with metal teeth. There are three types of zippers 1) Conventional zippers 2) Separating zippers 3) invisible zippers

Conventional zippers: These zippers, regardless of whether made with uncovered teeth (chain) or twist, open at the top and are held together at the base. They come in increasingly unexpected styles in contrast with some other zipper type. Dependent upon the piece of attire structure, application may be by the focused, lapped, revealed, or fly system.



6. Elastic is different kind of elastics available in the market and might be choose carefully as according by the end utilization of the garment. Elastic is available in different kind of widths. Braided elastic is suggested only for casing because it narrow when stretched. Woven elastic width of the elastic remains same even when extended thus can be sewed directly to the clothes or for

casing. Elastic thread is very thin covered elastic. It is generally utilized in bobbin for shirring effect in garment. Since it is twisted in bobbin for shirring it is called bobbin elastic. Special purpose elastic is used in night robe, lungies and swimwear.

7. Velcro is the two tape strips surface. Velcro is a set of two tapes one with a looped napped surface and other with a hooked napped surface. When pressed both the surfaces are together, they grip and remain locked until pulled apart. They are usually made of nylon and are available in meters and yards. Velcro is used on cuffs, plackets, mosquito nets, decorating home items and other such items. Velcro is popular in infant garments.
8. Broaches are a decorative item with a catch and a pin, which are fastened to the cloth. They serve as a functional as well as decorative fastener though the decorative element is more. They are usually embellished with gems and decorated heavily. Broaches made in metal and generally used for decoration on the garment.

Multiple Choice Questions

1(C) 2 (A) 3 (A) 4 (B) 5 (B) 6 (C) 7 (A)

યુનિવર્સિટી ગીત

સ્વાધ્યાય: પરમં તપ:

સ્વાધ્યાય: પરમં તપ:

સ્વાધ્યાય: પરમં તપ:

શિક્ષણ, સંસ્કૃતિ, સદ્ભાવ, દિવ્યબોધનું ધામ
ડૉ. બાબાસાહેબ આંબેડકર ઓપન યુનિવર્સિટી નામ;
સૌને સૌની પાંખ મળે, ને સૌને સૌનું આભ,
દશે દિશામાં સ્મિત વહે હો દશે દિશે શુભ-લાભ.

અભણ રહી અજ્ઞાનના શાને, અંધકારને પીવો ?
કહે બુદ્ધ આંબેડકર કહે, તું થા તારો દીવો;
શારદીય અજવાળા પહોંચ્યાં ગુર્જર ગામે ગામ
ધ્રુવ તારકની જેમ ઝળહળે એકલવ્યની શાન.

સરસ્વતીના મયૂર તમારે ફળિયે આવી ગહેકે
અંધકારને હડસેલીને ઉજાસના ફૂલ મહેંકે;
બંધન નહીં કો સ્થાન સમયના જવું ન ઘરથી દૂર
ઘર આવી મા હરે શારદા દૈન્ય તિમિરના પૂર.

સંસ્કારોની સુગંધ મહેંકે, મન મંદિરને ધામે
સુખની ટપાલ પહોંચે સૌને પોતાને સરનામે;
સમાજ કેરે દરિયે હાંકી શિક્ષણ કેરું વહાણ,
આવો કરીયે આપણ સૌ
ભવ્ય રાષ્ટ્ર નિર્માણ...
દિવ્ય રાષ્ટ્ર નિર્માણ...
ભવ્ય રાષ્ટ્ર નિર્માણ